

R290 · 220–240V | 50Hz · 115–127V | 60 Hz

# A NEW ROBUST PROPANE SOLUTION FOR GREEN AND EFFICIENT APPLIANCES

SECCP



KLF-CNDS | KLF-CNHS



Commercial Applications

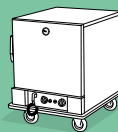
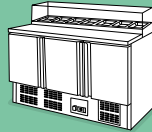
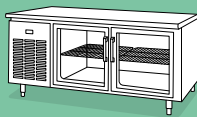

New Hermetic Terminal Plug



Broad Application Range (LBP & MBP)



Hot Gas Defrost



High Overload Robustness



Optimal Energy Consumption



R290 Green Refrigerant

## → Premium Robustness

The new muffler feature minimizes the risk of compressor or system damage due to extreme liquid return conditions

## → Robust Solution for Food Retail and Food Service Applications

Dedicated and reliable design for ice makers, coolers, and freezers (LBP and MBP applications) and is also suitable for food service applications

## → Superior Efficiency

High COP and top efficiency for light commercial applications with low GWP refrigerant propane (R290)

## → Innovative Solution for Flammable Refrigerants

Including a patented solution to increase robustness using propane that has been subject to extensive testing at Secop

## → Easier Application Assembly

New terminal board design for additional interconnections

## → Reduced Noise Level

Improved noise and reduced vibration, a new benchmark level for hydrocarbon refrigerants

Secop's new **KL-Series** is based on the very successful K-Series, Secop's core product for residential applications, with more than 50 million units installed.

Secop has developed a robust series for commercial refrigeration, which integrates various technical innovations, such as a noise-reducing shell, robust suspension, a robust internal discharge tube, improved valves, optimized motors, and a new muffler for lower noise levels when using propane. The KL-Series comes with a patented hermetic terminal plug designed to increase robustness for usage with flammable refrigerants.

The newly introduced types **KLF-CNDS** (220–240V / 50 Hz) and **KLF-CNHS** (115–127V / 60 Hz) have an optimized muffler system specially developed for applications with rapid load changes and extreme liquid return conditions. It increases the robustness and reliability of the cooling system against this type of overload. With these compressors, it is possible to remove ice from the evaporator surfaces by hot gas defrosting.

The KL-Series offers a reliable and robust design for commercial applications, specifically designed for R290 hydrocarbon refrigerant. This is the latest improvement on Secop's products for flammable refrigerants and will set a benchmark in the entire industry.

General	KLF4.0CNDS	KLF4.8CNDS	KLF5.6CNDS	KLF6.6CNDS	KLF7.7CNDS
Compressor	106H2403	106H2503	106H2603	106H2703	106H2803
Approvals	EN60335-1, EN 60335-2-34 with Annex AA, IEC/EN 60079-1, IEC/EN 60079-15, CCC* (*excluding KLF4.0CNDS)				

Application	R290				
Application	LBP/MBP	LBP/MBP	LBP/MBP	LBP/MBP	LBP/MBP
Evaporating temperature	°C	-40 to 7.2	-40 to 7.2	-40 to 7.2	-35 to 7.2
Voltage range / frequency	V/Hz	198-254/50	198-254/50	198-254/50	198-254/50

Performance Data ASHRAE LBP (220 V, 50 Hz • fan cooling)					
Evaporating temperature	°C	-23.3	-23.3	-23.3	-23.3
Cooling capacity	W	177	222	265	372
Power consumption	W	123	152	175	221
COP	W/W	1.44	1.46	1.51	1.47

Performance Data ASHRAE MBP (220 V, 50 Hz • fan cooling)					
Evaporating temp.	°C	-6.7	-6.7	-6.7	-6.7
Cooling capacity	W	324	395	477	574
Power consumption	W	160	197	236	293
COP	W/W	2.03	2.01	2.02	1.96

General	KLF4.0CNHS	KLF4.8CNHS	KLF5.6CNHS	KLF6.6CNHS	KLF7.7CNHS
Compressor	106H3403	106H3503	106H3603	106H3703	106H3803
Approvals	UL 60335-2-34, UL 60079-1, UL 60079-15, CCC				

Application	R290				
Application	LBP/MBP	LBP/MBP	LBP/MBP	LBP/MBP	LBP/MBP
Evaporating temperature	°F	-40 to 45	-40 to 45	-40 to 45	-40 to 45
Voltage range / frequency	V/Hz	95-140/60	95-140/60	95-140/60	95-140/60

Performance Data ASHRAE LBP (115 V, 60 Hz • fan cooling)					
Evaporating temperature	°F	-10	-10	-10	-10
Cooling capacity	BTU/h	751	918	1118	1310
Power consumption	W	152	177	209	244
EER	BTU/Wh	4.96	5.18	5.35	5.38

Performance Data ASHRAE MBP (115 V, 60 Hz • fan cooling)					
Evaporating temperature	°F	20	20	20	20
Cooling capacity	BTU/h	1379	1672	2004	2362
Power consumption	W	198	243	286	342
EER	BTU/Wh	6.96	6.89	7.01	6.91

Dimensions		KLF-CNDS (metric)		KLF-CNHS (inch)	
Height	mm (inch)	A	182	7.17	
		B	175	6.89	
Suction connector	location/I.D. mm (inch) angle   material   seal	C	8.2   30° Copper   Rubber plug	0.32-0.33   30° Copper   Rubber plug	
		D	6.2   35° Copper   Rubber plug	0.25-0.26   35° Copper   Rubber plug	
Discharge connector	location/I.D. mm (inch) angle   material   seal	E	6.2   40° Copper   Rubber plug	0.25-0.26   40° Copper   Rubber plug	
		Connector tolerance	I.D. mm	±0.09	-

Test conditions LBP: Condensing temp.: 54.4 °C (130 °F) | Suction gas temp.: 32.2 °C (90 °F) | Ambient temp.: 32.2 °C (90 °F) | Liquid temp.: 32.2 °C (90 °F)  
 MBP: Condensing temp.: 54.4 °C (130 °F) | Suction gas temp.: 35 °C (95 °F) | Ambient temp.: 32.2 °C (90 °F) | Liquid temp.: 46.1 °C (115 °F)

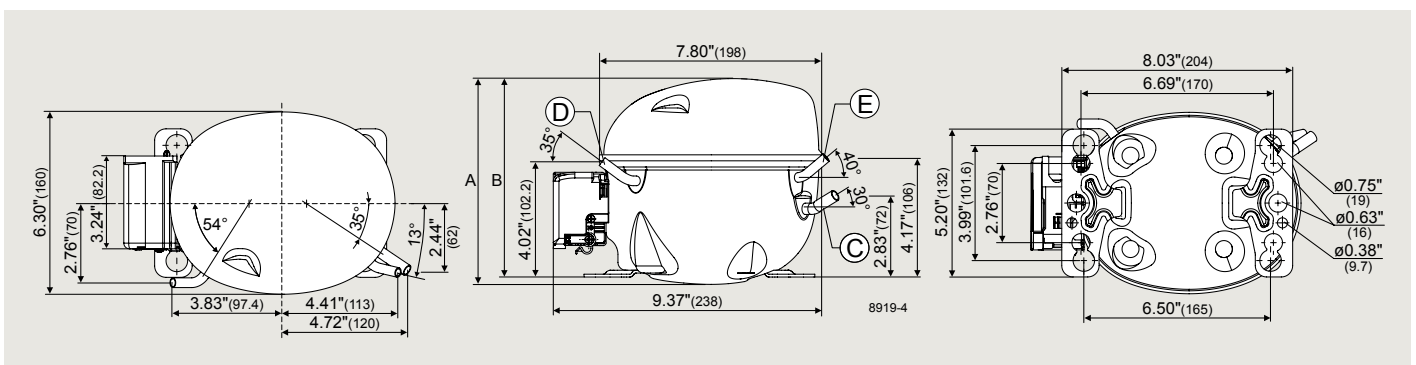

Secop GmbH · Lise-Meitner-Str. 29 · 24941 Flensburg, Germany · Tel: +49 461 4941 0 · [www.secop.com](http://www.secop.com)

Secop accepts no responsibility for possible errors in catalogs, brochures, and other printed material. Secop reserves the right to alter its products without notice. This also applies to products already on order provided that such alterations can be made without consequential changes being necessary to specifications already agreed. All trademarks in this material are the property of the respective companies. Secop and the Secop logotype are trademarks of Secop GmbH. All rights reserved.