

Model

Designation **CU GS26MLX MG_Z 230/1/50 VAL**



Sales code: 314L7003
Engineering code: CUGS26MLX00VE

Application Data

Power supply 220-240V / 50Hz 1~
Refrigerants R404A-R452A-R449A
Refr. charge - tech. limit 2000g / 70,5oz
Starter HST / capillary tube or expansion valve
Sound pressure (10m) 37,5dB(A)

Configuration data

	Conf. 1	Conf. 2	Conf. 3
Voltage range	198 - 254V / 50Hz	198 - 254V / 50Hz	198 - 254V / 50Hz
Refrigerant	R404A	R452A	R449A
Application	MBP	MBP	MBP
Rated performance	<u>pe=-10°C, Tsuc=20°C, Tamb=25°C, subcooling: 2K</u>		
Cooling capacity	2332W / 7965Btu/h	2233W / 7627Btu/h	2167W / 7401Btu/h
Power consumption	1240,5W	1152,3W	1088,9W
Current consumption	6,2A	5,8A	5,5A
COP/EER	1,88 / 6,42Btu/Wh	1,94 / 6,62Btu/Wh	1,99 / 6,8Btu/Wh
Approvals	Eco design (EU) 2015/1095, CE, UK CA, VDE	Eco design (EU) 2015/1095, CE, UK CA, VDE	Eco design (EU) 2015/1095, CE

Compressor

Designation **GS26MLX**
Motor configuration CSCR
Locked rotor amperage 35A
Rated load amperage 6,4A
Winding resistance main 1,8Ω
Winding resistance aux 8,1Ω
Oil quantity 900cm³ / 30,4fl.oz
Oil type POE
Horsepower rating 1 1/4 HP

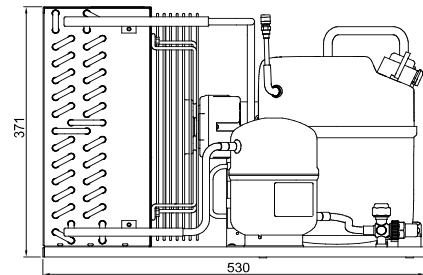

Dimensions

Condensing unit

Height x Width x Depth 371 x 430 x 530 [mm] / 14,6 x 16,9 x 20,9 [in]
Weight 41,8kg / 92,1lbs
Suction adapter FLARE 5/8"
Discharge adapter FLARE 3/8"
Process connector ø6,5mm / 0,26in

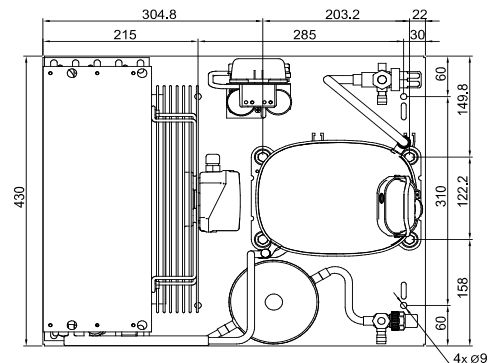

Package data

Height x Width x Depth 450 x 600 x 700 [mm] / 17,7 x 23,6 x 27,6 [in]
Weight 45,8kg / 100,9lbs

Model

Designation **CU GS26MLX MG_Z 230/1/50 VAL**

Sales code: 314L7003
Engineering code: CUGS26MLX00VE

Components Condensing-Unit / Spare Parts

Component	Type	Spare part code number
Compressor code	GS26MLX	107B0503
Condenser	Condenser (4 rows x 14 tubes)	1440350C70
Fan motor		60030441
Blade code	/	/
Air flow	1263m³/h	
Receiver code	Receiver 1,7 liter	120/182VS00
Suction valve code	FLARE 5/8"	FLARE 5/8"
Liquid valve code	FLARE 3/8"	FLARE 3/8"

Compressor starting equipment	Spare part code number
pos. a3 - GS starter kit (600mm)	117-7072
pos. b - cover	107B9101
pos. b2 - gasket	107B9100
pos. b1 - clamp	107B9104

Wiring Sketch Compressor

Wiring Sketch Condensing Unit

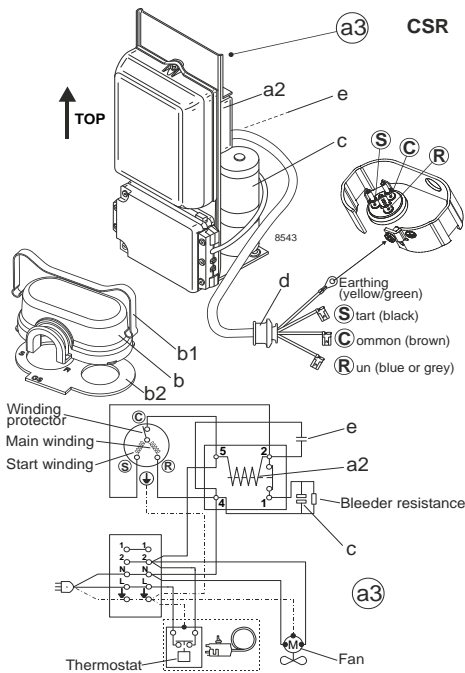

Model

Designation **CU GS26MLX MG_Z 230/1/50 VAL**

Sales code: 314L7003

Engineering code: CUGS26MLX00VE

Cooling performance - Conf. 1

Power supply	220-240V / 50Hz 1~	Voltage range	198 - 254V / 50Hz
Refr. charge - tech. limit	2000g / 70,5oz		
Starter	HST / capillary tube or expansion valve		
Motor configuration	CSCR		
Refrigerant	R404A		
Application	MBP		
Approvals	Eco design (EU) 2015/1095, CE, UK CA, VDE		

ambient temperature	[°C / °F]	25 / 77 (suction gas temperature [°C / °F]: 20 / 68, subcooling: 2K)						
evaporating temperature	[°C / °F]	-25 / -13	-20 / -4	-15 / 5	-10 / 14	0 / 32	5 / 41	10 / 50
cooling capacity	[W]	1334	1639	1974	2332	3094	3482	3865
COP	[W/W]	1,47	1,62	1,76	1,88	2,05	2,09	2,1
cooling capacity	[Btu/h]	4556	5597	6741	7963	10568	11892	13201
power consumption	[W]	910	1014	1123	1241	1509	1665	1838
current consumption	[A]	4,7	5,2	5,7	6,2	7,5	8,2	9

ambient temperature	[°C / °F]	32 / 90 (suction gas temperature [°C / °F]: 20 / 68, subcooling: 2K)				
evaporating temperature	[°C / °F]	-25 / -13	-20 / -4	-15 / 5	-10 / 14	0 / 32
cooling capacity	[W]	1161	1437	1736	2053	2717
COP	[W/W]	1,26	1,38	1,49	1,58	1,71
cooling capacity	[Btu/h]	3964	4908	5930	7012	9280
power consumption	[W]	924	1043	1166	1296	1590
current consumption	[A]	4,8	5,3	5,9	6,4	7,8

ambient temperature	[°C / °F]	38 / 100 (suction gas temperature [°C / °F]: 20 / 68, subcooling: 2K)			
evaporating temperature	[°C / °F]	-25 / -13	-20 / -4	-15 / 5	-10 / 14
cooling capacity	[W]	1016	1267	1535	1815
COP	[W/W]	1,09	1,19	1,28	1,35
cooling capacity	[Btu/h]	3468	4328	5241	6199
power consumption	[W]	932	1065	1202	1346
current consumption	[A]	4,9	5,4	6	6,6

ambient temperature	[°C / °F]	43 / 109 (suction gas temperature [°C / °F]: 20 / 68, subcooling: 2K)	
evaporating temperature	[°C / °F]	-25 / -13	-20 / -4
cooling capacity	[W]	897	1127
COP	[W/W]	0,96	1,04
cooling capacity	[Btu/h]	3063	3849
power consumption	[W]	936	1083
current consumption	[A]	4,9	5,5

Model

Designation **CU GS26MLX MG_Z 230/1/50 VAL**

Sales code: 314L7003

Engineering code: CUGS26MLX00VE

Cooling performance - Conf. 2

Power supply	220-240V / 50Hz 1~	Voltage range	198 - 254V / 50Hz
Refr. charge - tech. limit	2000g / 70,5oz		
Starter	HST / capillary tube or expansion valve		
Motor configuration	CSCR		
Refrigerant	R452A		
Application	MBP		
Approvals	Eco design (EU) 2015/1095, CE, UK CA, VDE		

ambient temperature	[°C / °F]	25 / 77 (suction gas temperature [°C / °F]: 20 / 68, subcooling: 2K)						
evaporating temperature	[°C / °F]	-25 / -13	-20 / -4	-15 / 5	-10 / 14	0 / 32	5 / 41	10 / 50
cooling capacity	[W]	1246	1585	1909	2233	2924	3308	3726
COP	[W/W]	1,48	1,71	1,85	1,94	2,03	2,07	2,1
cooling capacity	[Btu/h]	4254	5412	6520	7625	9987	11297	12725
power consumption	[W]	842	927	1032	1152	1438	1601	1777
current consumption	[A]	4,5	4,8	5,3	5,8	7,1	7,8	8,6

ambient temperature	[°C / °F]	32 / 90 (suction gas temperature [°C / °F]: 20 / 68, subcooling: 2K)						
evaporating temperature	[°C / °F]	-25 / -13	-20 / -4	-15 / 5	-10 / 14	0 / 32	5 / 41	
cooling capacity	[W]	1084	1386	1673	1958	2567	2909	
COP	[W/W]	1,27	1,45	1,56	1,62	1,69	1,71	
cooling capacity	[Btu/h]	3701	4734	5714	6687	8767	9934	
power consumption	[W]	853	954	1072	1207	1520	1697	
current consumption	[A]	4,5	4,9	5,5	6,1	7,4	8,2	

ambient temperature	[°C / °F]	38 / 100 (suction gas temperature [°C / °F]: 20 / 68, subcooling: 2K)			
evaporating temperature	[°C / °F]	-25 / -13	-20 / -4	-15 / 5	-10 / 14
cooling capacity	[W]	960	1228	1478	1726
COP	[W/W]	1,12	1,26	1,34	1,37
cooling capacity	[Btu/h]	3277	4194	5048	5893
power consumption	[W]	854	971	1106	1256
current consumption	[A]	4,5	5	5,6	6,3

ambient temperature	[°C / °F]	43 / 109 (suction gas temperature [°C / °F]: 20 / 68, subcooling: 2K)		
evaporating temperature	[°C / °F]	-25 / -13	-20 / -4	-15 / 5
cooling capacity	[W]	858	1094	1311
COP	[W/W]	1,01	1,11	1,15
cooling capacity	[Btu/h]	2930	3736	4479
power consumption	[W]	852	986	1138
current consumption	[A]	4,5	5,1	5,8

Model

Designation **CU GS26MLX MG_Z 230/1/50 VAL**

Sales code: 314L7003

Engineering code: CUGS26MLX00VE

Cooling performance - Conf. 3

Power supply	220-240V / 50Hz 1~	Voltage range	198 - 254V / 50Hz
Refr. charge - tech. limit	2000g / 70,5oz		
Starter	HST / capillary tube or expansion valve		
Motor configuration	CSCR		
Refrigerant	R449A		
Application	MBP		
Approvals	Eco design (EU) 2015/1095, CE		

ambient temperature	[°C / °F]	25 / 77 (suction gas temperature [°C / °F]: 20 / 68, subcooling: 2K)						
evaporating temperature	[°C / °F]	-20 / -4	-15 / 5	-10 / 14	-5 / 23	0 / 32	5 / 41	10 / 50
cooling capacity	[W]	1465	1799	2167	2566	2990	3435	3891
COP	[W/W]	1,66	1,83	1,99	2,13	2,24	2,34	2,39
cooling capacity	[Btu/h]	5002	6143	7400	8762	10213	11730	13289
power consumption	[W]	882	982	1089	1205	1332	1471	1625
current consumption	[A]	4,7	5,1	5,5	6	6,6	7,2	7,9

ambient temperature	[°C / °F]	32 / 90 (suction gas temperature [°C / °F]: 20 / 68, subcooling: 2K)						
evaporating temperature	[°C / °F]	-20 / -4	-15 / 5	-10 / 14	-5 / 23	0 / 32	5 / 41	
cooling capacity	[W]	1299	1603	1936	2295	2677	3075	
COP	[W/W]	1,43	1,57	1,7	1,82	1,91	1,99	
cooling capacity	[Btu/h]	4437	5474	6612	7839	9142	10503	
power consumption	[W]	907	1019	1137	1263	1400	1549	
current consumption	[A]	4,8	5,2	5,8	6,3	6,9	7,5	

ambient temperature	[°C / °F]	38 / 100 (suction gas temperature [°C / °F]: 20 / 68, subcooling: 2K)			
evaporating temperature	[°C / °F]	-20 / -4	-15 / 5	-10 / 14	-5 / 23
cooling capacity	[W]	1159	1437	1740	2065
COP	[W/W]	1,25	1,37	1,48	1,57
cooling capacity	[Btu/h]	3959	4909	5941	7051
power consumption	[W]	926	1049	1178	1315
current consumption	[A]	4,8	5,4	5,9	6,5

ambient temperature	[°C / °F]	43 / 109 (suction gas temperature [°C / °F]: 20 / 68, subcooling: 2K)	
evaporating temperature	[°C / °F]	-20 / -4	-15 / 5
cooling capacity	[W]	1044	1301
COP	[W/W]	1,11	1,21
cooling capacity	[Btu/h]	3567	4443
power consumption	[W]	940	1074
current consumption	[A]	4,9	5,5