

Model

Designation **CU GS34MFX MG_Y 230/1/50 VAL**



Sales code: 314G7006
Engineering code: CUGS34MFX00VE

Application Data

Power supply	220-240V / 50Hz 1~
Refrigerants	R134a-R513A
Refr. charge - tech. limit	2000g / 70,5oz
Starter	HST / capillary tube or expansion valve
Sound pressure (10m)	44,4dB(A)

Configuration data

	Conf. 1	Conf. 2
Voltage range	198 - 254V / 50Hz	198 - 254V / 50Hz
Refrigerant	R134a	R513A
Application	MBP	MBP

Rated performance	<u>pe=-10°C, Tsuc=20°C, Tamb=25°C, subcooling: 2K</u>	
Cooling capacity	1783W / 6088Btu/h	1865W / 6368Btu/h
Power consumption	918,4W	988,4W
Current consumption	4,7A	5A
COP/EER	1,94 / 6,63Btu/Wh	1,89 / 6,44Btu/Wh

Approvals	Eco design (EU) 2015/1095, CE, UK CA, VDE	Eco design (EU) 2015/1095, CE, UK CA, VDE
-----------	--	--

Compressor

Designation	GS34MFX
Motor configuration	CSCR
Locked rotor amperage	26A
Rated load amperage	4,8A
Winding resistance main	2,9Ω
Winding resistance aux	5Ω
Oil quantity	900cm ³ / 30,4fl.oz
Oil type	POE
Horsepower rating	3/4 HP

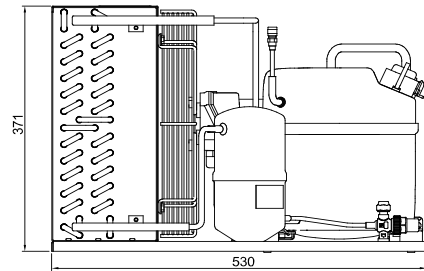

Dimensions

Condensing unit

Height x Width x Depth	371 x 430 x 530 [mm] / 14,6 x 16,9 x 20,9 [in]
Weight	37,6kg / 83lbs
Suction adapter	FLARE 1/2"
Discharge adapter	FLARE 1/4"
Process connector	ø6,5mm / 0,26in

Package data

Height x Width x Depth	450 x 600 x 700 [mm] / 17,7 x 23,6 x 27,6 [in]
Weight	41,6kg / 91,8lbs

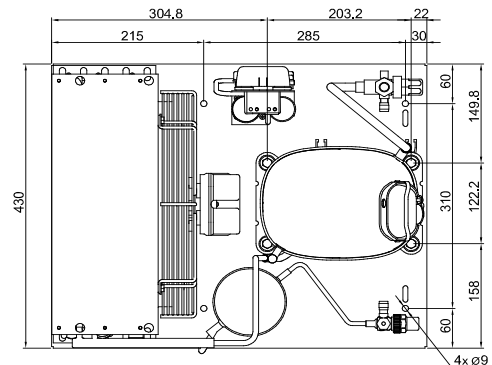

Model

Designation **CU GS34MFX MG_Y 230/1/50 VAL**

Sales code: 314G7006
Engineering code: CUGS34MFX00VE

Components Condensing-Unit / Spare Parts

Component	Type	Spare part code number
Compressor code	GS34MFX	107B0701
Condenser	Condenser (4 rows x 14 tubes)	1440350C70
Fan motor	35W	1BT35-25-1VNO
Blade code	ø300mm 28°	A300-28
Air flow	1034,4m³/h	
Receiver code	Receiver 1,3 liter	100/200VS00
Suction valve code	FLARE 1/2"	FLARE 1/2"
Liquid valve code	FLARE 1/4"	FLARE 1/4"

Compressor starting equipment	Spare part code number
pos. a3 - GS starter kit (600mm)	117-7056
pos. b - cover	107B9101
pos. b2 - gasket	107B9100
pos. b1 - clamp	107B9104

Wiring Sketch Compressor

Wiring Sketch Condensing Unit

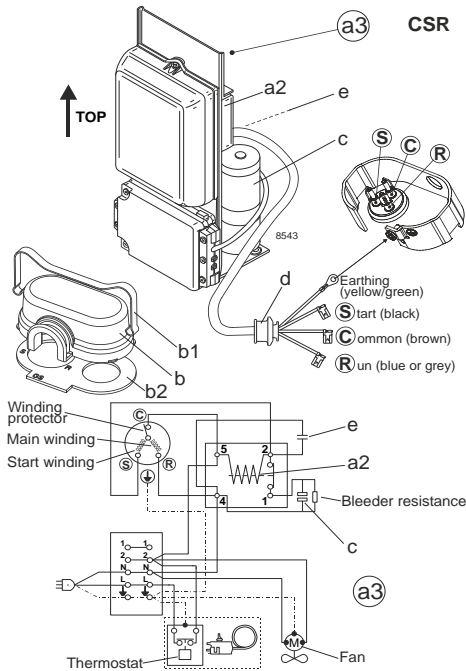

Model

Designation **CU GS34MFX MG_Y 230/1/50 VAL**

Sales code: 314G7006

Engineering code: CUGS34MFX00VE

Cooling performance - Conf. 1

Power supply	220-240V / 50Hz 1~	Voltage range	198 - 254V / 50Hz
Refr. charge - tech. limit	2000g / 70,5oz		
Starter	HST / capillary tube or expansion valve		
Motor configuration	CSCR		
Refrigerant	R134a		
Application	MBP		
Approvals	Eco design (EU) 2015/1095, CE, UK CA, VDE		

ambient temperature	[°C / °F]	25 / 77 (suction gas temperature [°C / °F]: 20 / 68, subcooling: 2K)						
evaporating temperature	[°C / °F]	-20 / -4	-15 / 5	-10 / 14	-5 / 23	0 / 32	5 / 41	10 / 50
cooling capacity	[W]	1169	1457	1782	2145	2542	2969	3423
COP	[W/W]	1,59	1,78	1,94	2,08	2,18	2,25	2,28
cooling capacity	[Btu/h]	3994	4975	6087	7324	8681	10141	11691
power consumption	[W]	733	820	918	1032	1165	1321	1503
current consumption	[A]	3,8	4,2	4,7	5,2	5,8	6,5	7,3

ambient temperature	[°C / °F]	32 / 90 (suction gas temperature [°C / °F]: 20 / 68, subcooling: 2K)						
evaporating temperature	[°C / °F]	-20 / -4	-15 / 5	-10 / 14	-5 / 23	0 / 32	5 / 41	10 / 50
cooling capacity	[W]	1054	1321	1622	1956	2321	2714	3130
COP	[W/W]	1,4	1,55	1,69	1,8	1,89	1,94	1,97
cooling capacity	[Btu/h]	3600	4512	5539	6679	7926	9268	10690
power consumption	[W]	752	850	959	1084	1229	1396	1592
current consumption	[A]	3,9	4,3	4,8	5,4	6	6,7	7,5

ambient temperature	[°C / °F]	38 / 100 (suction gas temperature [°C / °F]: 20 / 68, subcooling: 2K)						
evaporating temperature	[°C / °F]	-20 / -4	-15 / 5	-10 / 14	-5 / 23	0 / 32		
cooling capacity	[W]	954	1203	1482	1792	2129		
COP	[W/W]	1,25	1,37	1,48	1,58	1,65		
cooling capacity	[Btu/h]	3257	4108	5062	6119	7270		
power consumption	[W]	766	876	998	1135	1292		
current consumption	[A]	4	4,4	4,9	5,5	6,1		

ambient temperature	[°C / °F]	43 / 109 (suction gas temperature [°C / °F]: 20 / 68, subcooling: 2K)						
evaporating temperature	[°C / °F]	-20 / -4	-15 / 5	-10 / 14	-5 / 23			
cooling capacity	[W]	869	1104	1365	1654			
COP	[W/W]	1,12	1,23	1,32	1,4			
cooling capacity	[Btu/h]	2969	3769	4662	5648			
power consumption	[W]	774	898	1032	1181			
current consumption	[A]	4	4,5	5	5,6			

Model

Designation **CU GS34MFX MG_Y 230/1/50 VAL**

Sales code: 314G7006

Engineering code: CUGS34MFX00VE

Cooling performance - Conf. 2

Power supply	220-240V / 50Hz 1~	Voltage range	198 - 254V / 50Hz
Refr. charge - tech. limit	2000g / 70,5oz		
Starter	HST / capillary tube or expansion valve		
Motor configuration	CSCR		
Refrigerant	R513A		
Application	MBP		
Approvals	Eco design (EU) 2015/1095, CE, UK CA, VDE		

ambient temperature	[°C / °F]	25 / 77 (suction gas temperature [°C / °F]: 20 / 68, subcooling: 2K)						
evaporating temperature	[°C / °F]	-20 / -4	-15 / 5	-10 / 14	-5 / 23	0 / 32	5 / 41	10 / 50
cooling capacity	[W]	1252	1542	1864	2219	2598	3000	3414
COP	[W/W]	1,57	1,74	1,89	2	2,09	2,13	2,13
cooling capacity	[Btu/h]	4276	5265	6367	7577	8874	10245	11661
power consumption	[W]	795	886	988	1107	1246	1410	1604
current consumption	[A]	4,2	4,6	5	5,5	6,1	6,8	7,7

ambient temperature	[°C / °F]	32 / 90 (suction gas temperature [°C / °F]: 20 / 68, subcooling: 2K)						
evaporating temperature	[°C / °F]	-20 / -4	-15 / 5	-10 / 14	-5 / 23	0 / 32	5 / 41	10 / 50
cooling capacity	[W]	1123	1390	1685	2006	2351	2713	3086
COP	[W/W]	1,37	1,51	1,63	1,72	1,78	1,81	1,81
cooling capacity	[Btu/h]	3836	4746	5754	6852	8029	9265	10540
power consumption	[W]	818	921	1035	1166	1318	1495	1703
current consumption	[A]	4,3	4,7	5,2	5,8	6,4	7,2	8,1

ambient temperature	[°C / °F]	38 / 100 (suction gas temperature [°C / °F]: 20 / 68, subcooling: 2K)				
evaporating temperature	[°C / °F]	-20 / -4	-15 / 5	-10 / 14	-5 / 23	0 / 32
cooling capacity	[W]	1011	1257	1528	1822	2135
COP	[W/W]	1,21	1,32	1,42	1,49	1,54
cooling capacity	[Btu/h]	3453	4292	5217	6221	7290
power consumption	[W]	835	951	1079	1223	1388
current consumption	[A]	4,3	4,8	5,4	6	6,7

ambient temperature	[°C / °F]	43 / 109 (suction gas temperature [°C / °F]: 20 / 68, subcooling: 2K)		
evaporating temperature	[°C / °F]	-20 / -4	-15 / 5	-10 / 14
cooling capacity	[W]	917	1145	1395
COP	[W/W]	1,08	1,17	1,25
cooling capacity	[Btu/h]	3131	3911	4766
power consumption	[W]	846	976	1118
current consumption	[A]	4,4	5	5,6