

Model

Designation **CU NF7MLX MG_Z 230/1/50 CAP**



Sales code: 314L5006
Engineering code: CUNF7MLX000CE

Application Data

Power supply	220-240V / 50Hz 1~
Refrigerants	R404A-R452A
Refr. charge - tech. limit	400g / 14,1oz
Starter	HST / capillary tube or expansion valve
Sound pressure (10m)	36,2dB(A)

Configuration data

	Conf. 1	Conf. 2
Voltage range	187 - 254V / 50Hz	187 - 254V / 50Hz
Refrigerant	R404A	R452A
Application	MBP	MBP

Rated performance	<u>pe=-10°C, Tsuc=20°C, Tamb=25°C, subcooling: 2K</u>	
Cooling capacity	700W / 2389Btu/h	666W / 2274Btu/h
Power consumption	405,6W	381,6W
Current consumption	3,2A	3,1A
COP/EER	1,72 / 5,89Btu/Wh	1,74 / 5,96Btu/Wh

Approvals	Eco design (EU) 2015/1095, CE, UK CA, VDE	Eco design (EU) 2015/1095, CE, UK CA, VDE
-----------	--	--

Compressor

Designation	NF7MLX
Motor configuration	CSIR
Locked rotor amperage	20A
Rated load amperage	3,7A
Winding resistance main	4,5Ω
Winding resistance aux	12,8Ω
Oil quantity	300cm ³ / 10,1fl.oz
Oil type	POE
Horsepower rating	1/3 HP

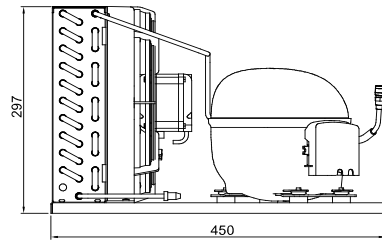

Dimensions

Condensing unit

Height x Width x Depth	297 x 350 x 450 [mm] / 11,7 x 13,8 x 17,7 [in]
Weight	16,8kg / 37lbs
Suction adapter	OD ø10mm / 2/5in
Discharge adapter	OD ø6mm / 1/4in
Process connector	ø6,5mm / 0,26in

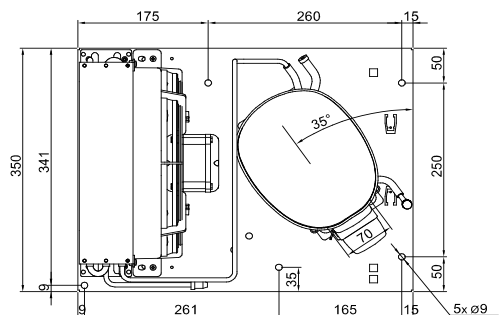

Package data

Height x Width x Depth	350 x 450 x 550 [mm] / 13,8 x 17,7 x 21,7 [in]
Weight	19,8kg / 43,6lbs

Model

Designation **CU NF7MLX MG_Z 230/1/50 CAP**

Sales code: 314L5006
Engineering code: CUNF7MLX000CE

Components Condensing-Unit / Spare Parts

Component	Type	Spare part code number
Compressor code	NF7MLX	105F3727
Condenser	Condenser (3 rows x 11 tubes)	1130270F70
Fan motor	18W	NET3T18PVN004
Blade code	ø254mm 22°	A254-22
Air flow	628m³/h	
Receiver code	not installed	-/-
Suction valve code	OD ø10mm / 2/5in	-/-
Liquid valve code	OD ø6mm / 1/4in	-/-

Compressor starting equipment	Spare part code number
pos. a2 - relay (protector: TI MRP5)	117U4139
pos. c - start capacitor	117U5018
pos. b - plastic cover	117U1021
pos. d/dc - cord relief	117U0349
pos. -	117U0349

Wiring Sketch Compressor

Wiring Sketch Condensing Unit

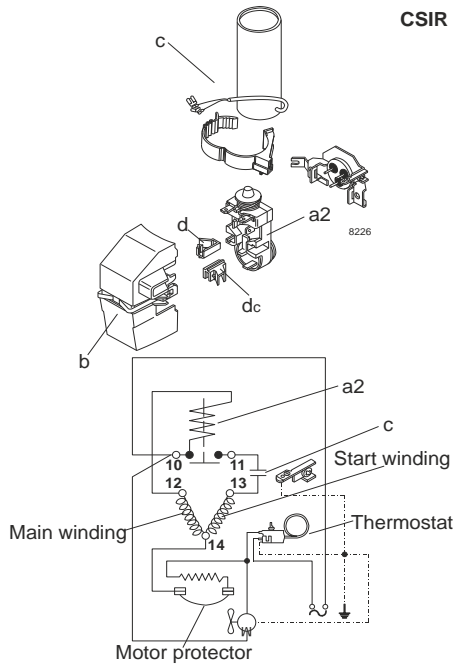

Model

Designation **CU NF7MLX MG_Z 230/1/50 CAP**

Sales code: 314L5006

Engineering code: CUNF7MLX000CE

Cooling performance - Conf. 1

Power supply	220-240V / 50Hz 1~	Voltage range	187 - 254V / 50Hz
Refr. charge - tech. limit	400g / 14,1oz		
Starter	HST / capillary tube or expansion valve		
Motor configuration	CSIR		
Refrigerant	R404A		
Application	MBP		
Approvals	Eco design (EU) 2015/1095, CE, UK CA, VDE		

ambient temperature	[°C / °F]	25 / 77 (suction gas temperature [°C / °F]: 20 / 68, subcooling: 2K)						
evaporating temperature	[°C / °F]	-15 / 5	-10 / 14	-6,7 / 20	-5 / 23	0 / 32	5 / 41	10 / 50
cooling capacity	[W]	585	700	781	825	959	1102	1251
COP	[W/W]	1,56	1,72	1,83	1,89	2,04	2,2	2,34
cooling capacity	[Btu/h]	1998	2389	2667	2816	3275	3764	4273
power consumption	[W]	375	406	426	437	469	501	535
current consumption	[A]	3,1	3,2	3,2	3,2	3,4	3,5	3,6

ambient temperature	[°C / °F]	32 / 90 (suction gas temperature [°C / °F]: 20 / 68, subcooling: 2K)						
evaporating temperature	[°C / °F]	-15 / 5	-10 / 14	-6,7 / 20	-5 / 23	0 / 32	5 / 41	10 / 50
cooling capacity	[W]	518	621	693	732	852	979	1111
COP	[W/W]	1,34	1,47	1,55	1,6	1,72	1,85	1,96
cooling capacity	[Btu/h]	1768	2119	2367	2501	2911	3343	3794
power consumption	[W]	387	422	446	458	494	530	568
current consumption	[A]	3,1	3,2	3,3	3,3	3,4	3,6	3,7

ambient temperature	[°C / °F]	38 / 100 (suction gas temperature [°C / °F]: 20 / 68, subcooling: 2K)				
evaporating temperature	[°C / °F]	-15 / 5	-10 / 14	-6,7 / 20	-5 / 23	0 / 32
cooling capacity	[W]	459	552	618	652	760
COP	[W/W]	1,15	1,26	1,33	1,37	1,47
cooling capacity	[Btu/h]	1569	1886	2109	2228	2594
power consumption	[W]	400	438	464	477	517
current consumption	[A]	3,1	3,2	3,3	3,4	3,5

ambient temperature	[°C / °F]	43 / 109 (suction gas temperature [°C / °F]: 20 / 68, subcooling: 2K)	
evaporating temperature	[°C / °F]	-15 / 5	-10 / 14
cooling capacity	[W]	411	494
COP	[W/W]	1	1,09
cooling capacity	[Btu/h]	1402	1689
power consumption	[W]	411	453
current consumption	[A]	3,1	3,3

Model

Designation **CU NF7MLX MG_Z 230/1/50 CAP**

Sales code: 314L5006

Engineering code: CUNF7MLX000CE

Cooling performance - Conf. 2

Power supply	220-240V / 50Hz 1~	Voltage range	187 - 254V / 50Hz
Refr. charge - tech. limit	400g / 14,1oz		
Starter	HST / capillary tube or expansion valve		
Motor configuration	CSIR		
Refrigerant	R452A		
Application	MBP		
Approvals	Eco design (EU) 2015/1095, CE, UK CA, VDE		

ambient temperature	[°C / °F]	25 / 77 (suction gas temperature [°C / °F]: 20 / 68, subcooling: 2K)						
evaporating temperature	[°C / °F]	-15 / 5	-10 / 14	-6,7 / 20	-5 / 23	0 / 32	5 / 41	10 / 50
cooling capacity	[W]	553	666	746	790	924	1068	1219
COP	[W/W]	1,58	1,74	1,86	1,91	2,08	2,23	2,38
cooling capacity	[Btu/h]	1890	2274	2549	2698	3157	3647	4164
power consumption	[W]	351	382	402	413	445	478	513
current consumption	[A]	3	3,1	3,2	3,2	3,3	3,4	3,5

ambient temperature	[°C / °F]	32 / 90 (suction gas temperature [°C / °F]: 20 / 68, subcooling: 2K)						
evaporating temperature	[°C / °F]	-15 / 5	-10 / 14	-6,7 / 20	-5 / 23	0 / 32	5 / 41	10 / 50
cooling capacity	[W]	490	592	665	704	825	953	1088
COP	[W/W]	1,35	1,49	1,58	1,63	1,76	1,88	2
cooling capacity	[Btu/h]	1675	2023	2271	2404	2816	3256	3716
power consumption	[W]	363	397	420	432	468	506	544
current consumption	[A]	3	3,1	3,2	3,2	3,4	3,5	3,6

ambient temperature	[°C / °F]	38 / 100 (suction gas temperature [°C / °F]: 20 / 68, subcooling: 2K)						
evaporating temperature	[°C / °F]	-15 / 5	-10 / 14	-6,7 / 20	-5 / 23	0 / 32	5 / 41	
cooling capacity	[W]	437	529	595	630	738	854	
COP	[W/W]	1,17	1,28	1,36	1,4	1,51	1,61	
cooling capacity	[Btu/h]	1491	1806	2030	2150	2521	2915	
power consumption	[W]	374	412	437	450	490	531	
current consumption	[A]	3,1	3,2	3,3	3,3	3,4	3,5	

ambient temperature	[°C / °F]	43 / 109 (suction gas temperature [°C / °F]: 20 / 68, subcooling: 2K)		
evaporating temperature	[°C / °F]	-15 / 5	-10 / 14	-6,7 / 20
cooling capacity	[W]	391	475	535
COP	[W/W]	1,02	1,12	1,18
cooling capacity	[Btu/h]	1336	1624	1827
power consumption	[W]	384	425	452
current consumption	[A]	3,1	3,2	3,3