

Model

Designation **CU NL7.3MF MG_Y 230/1/50 VAL**



Sales code: 314G5003
Engineering code: CUNL73MF000VE

Application Data

Power supply 220-240V / 50Hz 1~
Refrigerants R134a-R513A
Refr. charge - tech. limit 600g / 21,2oz
Starter HST / capillary tube or expansion valve
Sound pressure (10m) 26,3dB(A)

Configuration data

	Conf. 1	Conf. 2
Voltage range	187 - 254V / 50Hz	187 - 254V / 50Hz
Refrigerant	R134a	R513A
Application	MBP	MBP
Rated performance	<u>pe=-10°C, Tsuc=20°C, Tamb=25°C, subccoling: 2K</u>	
Cooling capacity	401W / 1371Btu/h	421W / 1439Btu/h
Power consumption	215,3W	227,3W
Current consumption	1,6A	1,7A
COP/EER	1,86 / 6,37Btu/Wh	1,85 / 6,33Btu/Wh
Approvals	Eco design (EU) 2015/1095, CE, UK CA, VDE	Eco design (EU) 2015/1095, CE, UK CA, VDE

Compressor

Designation **NL7.3MF**
Motor configuration CSIR
Locked rotor amperage 10,7A
Rated load amperage 2,1A
Winding resistance main 8,3Ω
Winding resistance aux 11,8Ω
Oil quantity 270cm³ / 9,1fl.oz
Oil type POE
Horsepower rating 1/6 HP

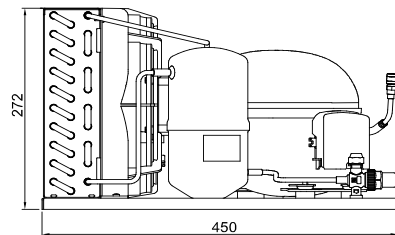

Dimensions

Condensing unit

Height x Width x Depth 272 x 350 x 450 [mm] / 10,7 x 13,8 x 17,7 [in]
Weight 18,3kg / 40,4lbs
Suction adapter FLARE 1/4"
Discharge adapter FLARE 1/4"
Process connector ø6,5mm / 0,26in

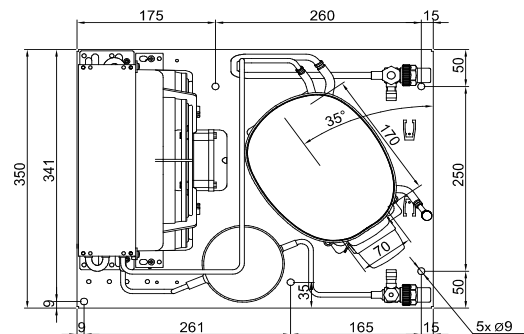

Package data

Height x Width x Depth 350 x 450 x 550 [mm] / 13,8 x 17,7 x 21,7 [in]
Weight 21,3kg / 47lbs

Model

Designation **CU NL7.3MF MG_Y 230/1/50 VAL**

Sales code: 314G5003
Engineering code: CUNL73MF000VE

Components Condensing-Unit / Spare Parts

Component	Type	Spare part code number
Compressor code	NL7.3MF	105G6773
Condenser	Condenser (3 rows x 10 tubes)	1030240F70
Fan motor	10W	AA707710X
Blade code	ø230mm 22°	A230-22
Air flow	385,8m³/h	
Receiver code	Receiver 1,3 liter	100/200VS00
Suction valve code	FLARE 1/4"	FLARE 1/4"
Liquid valve code	FLARE 1/4"	FLARE 1/4"

Compressor starting equipment	Spare part code number
pos. a2 - relay	117U6016
pos. c - start capacitor (80µF)	117U5015
pos. b - plastic cover	103N2011
pos. d - cord relief	103N1010

Wiring Sketch Compressor

Wiring Sketch Condensing Unit

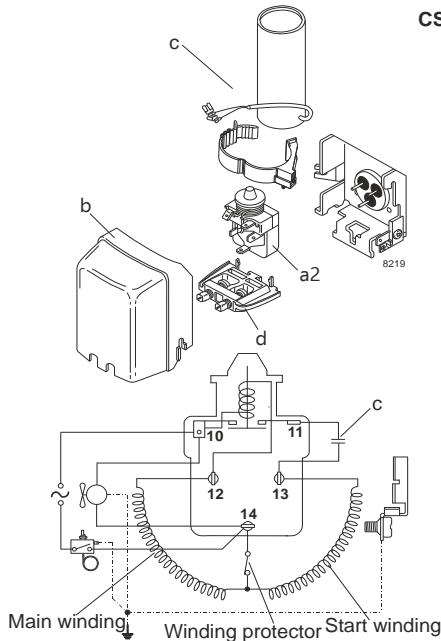

Model

Designation **CU NL7.3MF MG_Y 230/1/50 VAL**

Sales code: 314G5003

Engineering code: CUNL73MF000VE

Cooling performance - Conf. 1

Power supply	220-240V / 50Hz 1~	Voltage range	187 - 254V / 50Hz
Refr. charge - tech. limit	600g / 21,2oz		
Starter	HST / capillary tube or expansion valve		
Motor configuration	CSIR		
Refrigerant	R134a		
Application	MBP		
Approvals	Eco design (EU) 2015/1095, CE, UK CA, VDE		

ambient temperature	[°C / °F]	25 / 77 (suction gas temperature [°C / °F]: 20 / 68, subcooling: 2K)						
evaporating temperature	[°C / °F]	-20 / -4	-15 / 5	-10 / 14	-5 / 23	0 / 32	5 / 41	15 / 59
cooling capacity	[W]	257	324	401	489	585	691	923
COP	[W/W]	1,44	1,65	1,87	2,07	2,26	2,42	2,66
cooling capacity	[Btu/h]	876	1107	1371	1669	1999	2358	3152
power consumption	[W]	179	196	215	236	259	285	347
current consumption	[A]	1,6	1,6	1,6	1,7	1,8	1,9	2,1

ambient temperature	[°C / °F]	32 / 90 (suction gas temperature [°C / °F]: 20 / 68, subcooling: 2K)						
evaporating temperature	[°C / °F]	-20 / -4	-15 / 5	-10 / 14	-5 / 23	0 / 32	5 / 41	15 / 59
cooling capacity	[W]	231	293	364	444	532	629	843
COP	[W/W]	1,26	1,45	1,63	1,81	1,97	2,12	2,33
cooling capacity	[Btu/h]	788	1000	1243	1516	1818	2148	2878
power consumption	[W]	183	202	223	245	270	297	362
current consumption	[A]	1,6	1,6	1,7	1,7	1,8	1,9	2,2

ambient temperature	[°C / °F]	38 / 100 (suction gas temperature [°C / °F]: 20 / 68, subcooling: 2K)						
evaporating temperature	[°C / °F]	-20 / -4	-15 / 5	-10 / 14	-5 / 23	0 / 32	5 / 41	15 / 59
cooling capacity	[W]	209	267	332	406	488	577	774
COP	[W/W]	1,12	1,29	1,45	1,6	1,75	1,87	2,06
cooling capacity	[Btu/h]	715	911	1135	1387	1665	1970	2644
power consumption	[W]	186	207	229	253	279	308	376
current consumption	[A]	1,6	1,7	1,7	1,8	1,9	2	2,2

ambient temperature	[°C / °F]	43 / 109 (suction gas temperature [°C / °F]: 20 / 68, subcooling: 2K)						
evaporating temperature	[°C / °F]	-20 / -4	-15 / 5	-10 / 14	-5 / 23	0 / 32	5 / 41	
cooling capacity	[W]	192	245	306	375	451	534	
COP	[W/W]	1,02	1,16	1,3	1,44	1,57	1,68	
cooling capacity	[Btu/h]	656	838	1046	1280	1539	1823	
power consumption	[W]	189	211	235	260	288	318	
current consumption	[A]	1,6	1,7	1,7	1,8	1,9	2	

Model

Designation **CU NL7.3MF MG_Y 230/1/50 VAL**

Sales code: 314G5003

Engineering code: CUNL73MF000VE

Cooling performance - Conf. 2

Power supply	220-240V / 50Hz 1~	Voltage range	187 - 254V / 50Hz					
Refr. charge - tech. limit	600g / 21,2oz							
Starter	HST / capillary tube or expansion valve							
Motor configuration	CSIR							
Refrigerant	R513A							
Application	MBP							
Approvals	Eco design (EU) 2015/1095, CE, UK CA, VDE							

ambient temperature	[°C / °F]	25 / 77							(suction gas temperature [°C / °F]: 20 / 68, subcooling: 2K)
evaporating temperature	[°C / °F]	-20 / -4	-15 / 5	-10 / 14	-5 / 23	0 / 32	5 / 41	15 / 59	
cooling capacity	[W]	275	344	421	508	603	705	928	
COP	[W/W]	1,45	1,65	1,85	2,05	2,22	2,37	2,58	
cooling capacity	[Btu/h]	940	1173	1439	1735	2058	2408	3168	
power consumption	[W]	190	208	227	248	272	298	360	
current consumption	[A]	1,6	1,7	1,7	1,8	1,8	1,9	2,1	

ambient temperature	[°C / °F]	32 / 90							(suction gas temperature [°C / °F]: 20 / 68, subcooling: 2K)
evaporating temperature	[°C / °F]	-20 / -4	-15 / 5	-10 / 14	-5 / 23	0 / 32	5 / 41	15 / 59	
cooling capacity	[W]	246	309	379	458	544	637	839	
COP	[W/W]	1,26	1,44	1,61	1,78	1,92	2,05	2,24	
cooling capacity	[Btu/h]	842	1055	1296	1565	1859	2176	2867	
power consumption	[W]	195	214	235	258	283	310	375	
current consumption	[A]	1,6	1,7	1,7	1,8	1,9	1,9	2,1	

ambient temperature	[°C / °F]	38 / 100							(suction gas temperature [°C / °F]: 20 / 68, subcooling: 2K)
evaporating temperature	[°C / °F]	-20 / -4	-15 / 5	-10 / 14	-5 / 23	0 / 32	5 / 41	15 / 59	
cooling capacity	[W]	222	280	344	416	494	579	764	
COP	[W/W]	1,12	1,27	1,42	1,56	1,69	1,8	1,96	
cooling capacity	[Btu/h]	760	955	1175	1420	1689	1978	2609	
power consumption	[W]	199	220	243	267	293	322	390	
current consumption	[A]	1,6	1,7	1,8	1,8	1,9	2	2,1	

ambient temperature	[°C / °F]	43 / 109							(suction gas temperature [°C / °F]: 20 / 68, subcooling: 2K)
evaporating temperature	[°C / °F]	-20 / -4	-15 / 5	-10 / 14	-5 / 23	0 / 32	5 / 41		
cooling capacity	[W]	203	256	315	381	453	531		
COP	[W/W]	1	1,14	1,27	1,39	1,5	1,6		
cooling capacity	[Btu/h]	693	873	1076	1301	1548	1814		
power consumption	[W]	202	225	249	275	302	332		
current consumption	[A]	1,6	1,7	1,8	1,8	1,9	2		