

Model

Designation

CU NLE11MF.2 MG_Y 230/1/50 CAP



Sales code:

314G5008

Engineering code:

CUNLE11MF20CE

Application Data

Power supply	220-240V / 50Hz 1~
Refrigerants	R134a-R513A
Refr. charge - tech. limit	600g / 21,2oz
Starter	HST / capillary tube or expansion valve
Sound pressure (10m)	28,5dB(A)

Configuration data

	Conf. 1	Conf. 2
Voltage range	198 - 242V / 50Hz	198 - 254V / 50Hz
Refrigerant	R134a	R513A
Application	MBP	MBP

Rated performance	<u>pe=-10°C, Tsuc=20°C, Tamb=25°C, subcooling: 2K</u>	
Cooling capacity	636W / 2173Btu/h	663W / 2266Btu/h
Power consumption	319,4W	340,9W
Current consumption	2,1A	2,1A
COP/EER	1,99 / 6,8Btu/Wh	1,95 / 6,65Btu/Wh

Approvals	Eco design (EU) 2015/1095, CE, UK CA, VDE	Eco design (EU) 2015/1095, CE, UK CA, VDE
-----------	--	--

Compressor

Designation	NLE11MF.2
Motor configuration	CSIR
Locked rotor amperage	13,12A
Rated load amperage	2,29A
Winding resistance main	8,84Ω
Winding resistance aux	19,04Ω
Oil quantity	300cm ³ / 10,1fl.oz
Oil type	POE
Horsepower rating	3/10 HP

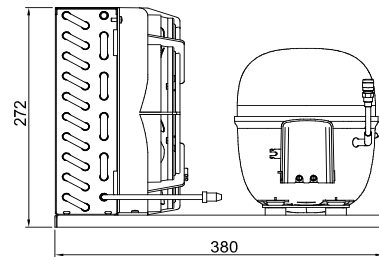

Dimensions

Condensing unit

Height x Width x Depth	272 x 300 x 380 [mm] / 10,7 x 11,8 x 15 [in]
Weight	17,4kg / 38,4lbs
Suction adapter	OD ø8mm / 1/3in
Discharge adapter	OD ø6mm / 1/4in
Process connector	ø6,2mm / 0,24in

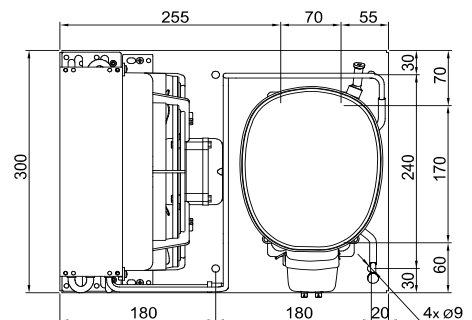

Package data

Height x Width x Depth	350 x 400 x 500 [mm] / 13,8 x 15,7 x 19,7 [in]
Weight	20,4kg / 45,1lbs

Model

Designation **CU NLE11MF.2 MG_Y 230/1/50 CAP**

Sales code: 314G5008
Engineering code: CUNLE11MF20CE

Components Condensing-Unit / Spare Parts

Component	Type	Spare part code number
Compressor code	NLE11MF.2	105G7101
Condenser	Condenser (3 rows x 10 tubes)	1030240F70
Fan motor	10W	AA707710X
Blade code	ø230mm 28°	A230-28
Air flow	462m³/h	
Receiver code	not installed	-/-
Suction valve code	OD ø8mm / 1/3in	-/-
Liquid valve code	OD ø6mm / 1/4in	-/-

Compressor starting equipment	Spare part code number
pos. a2 - assy. relay	117U6003
pos. c - start capacitor (80µF)	117U5015
pos. b - plastic cover	103N2010
pos. d - cord relief	103N1010

Wiring Sketch Compressor

Wiring Sketch Condensing Unit

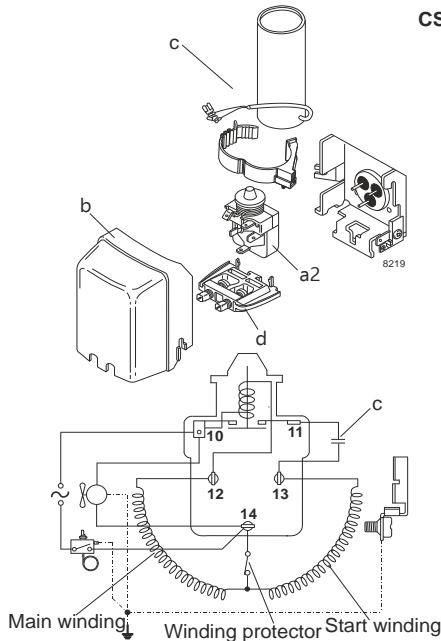

Model

Designation **CU NLE11MF.2 MG_Y 230/1/50 CAP**

Sales code: 314G5008

Engineering code: CUNLE11MF20CE

Cooling performance - Conf. 1

Power supply	220-240V / 50Hz 1~	Voltage range	198 - 242V / 50Hz
Refr. charge - tech. limit	600g / 21,2oz		
Starter	HST / capillary tube or expansion valve		
Motor configuration	CSIR		
Refrigerant	R134a		
Application	MBP		
Approvals	Eco design (EU) 2015/1095, CE, UK CA, VDE		

ambient temperature	[°C / °F]	25 / 77 (suction gas temperature [°C / °F]: 20 / 68, subcooling: 2K)						
evaporating temperature	[°C / °F]	-25 / -13	-20 / -4	-15 / 5	-10 / 14	0 / 32	5 / 41	10 / 50
cooling capacity	[W]	320	414	520	636	899	1044	1196
COP	[W/W]	1,46	1,66	1,84	1,99	2,22	2,28	2,31
cooling capacity	[Btu/h]	1092	1415	1775	2173	3070	3564	4083
power consumption	[W]	219	250	283	319	405	457	518
current consumption	[A]	1,7	1,8	2	2,1	2,3	2,5	2,8

ambient temperature	[°C / °F]	32 / 90 (suction gas temperature [°C / °F]: 20 / 68, subcooling: 2K)						
evaporating temperature	[°C / °F]	-25 / -13	-20 / -4	-15 / 5	-10 / 14	0 / 32	5 / 41	10 / 50
cooling capacity	[W]	304	386	478	581	818	951	1091
COP	[W/W]	1,33	1,49	1,63	1,74	1,91	1,95	1,96
cooling capacity	[Btu/h]	1039	1318	1633	1986	2795	3246	3726
power consumption	[W]	228	259	294	333	429	488	557
current consumption	[A]	1,8	1,9	2	2,1	2,4	2,7	3

ambient temperature	[°C / °F]	38 / 100 (suction gas temperature [°C / °F]: 20 / 68, subcooling: 2K)						
evaporating temperature	[°C / °F]	-25 / -13	-20 / -4	-15 / 5	-10 / 14	0 / 32	5 / 41	
cooling capacity	[W]	277	350	434	529	749	873	
COP	[W/W]	1,18	1,32	1,44	1,54	1,68	1,71	
cooling capacity	[Btu/h]	945	1196	1483	1806	2557	2983	
power consumption	[W]	234	265	301	343	446	511	
current consumption	[A]	1,9	2	2,1	2,2	2,5	2,8	

ambient temperature	[°C / °F]	43 / 109 (suction gas temperature [°C / °F]: 20 / 68, subcooling: 2K)						
evaporating temperature	[°C / °F]	-25 / -13	-20 / -4	-15 / 5	-10 / 14	0 / 32		
cooling capacity	[W]	251	319	397	486	695		
COP	[W/W]	1,07	1,19	1,31	1,4	1,52		
cooling capacity	[Btu/h]	857	1089	1355	1659	2372		
power consumption	[W]	235	267	304	348	458		
current consumption	[A]	1,8	1,9	2	2,2	2,6		

Model

Designation **CU NLE11MF.2 MG_Y 230/1/50 CAP**

Sales code: 314G5008

Engineering code: CUNLE11MF20CE

Cooling performance - Conf. 2

Power supply	220-240V / 50Hz 1~	Voltage range	198 - 254V / 50Hz
Refr. charge - tech. limit	600g / 21,2oz		
Starter	HST / capillary tube or expansion valve		
Motor configuration	CSIR		
Refrigerant	R513A		
Application	MBP		
Approvals	Eco design (EU) 2015/1095, CE, UK CA, VDE		

ambient temperature	[°C / °F]	25 / 77 (suction gas temperature [°C / °F]: 20 / 68, subcooling: 2K)						
evaporating temperature	[°C / °F]	-15 / 5	-10 / 14	-6,7 / 20	-5 / 23	0 / 32	5 / 41	10 / 50
cooling capacity	[W]	549	663	743	786	915	1052	1193
COP	[W/W]	1,81	1,94	2,02	2,05	2,13	2,17	2,18
cooling capacity	[Btu/h]	1876	2265	2538	2683	3126	3591	4075
power consumption	[W]	303	341	368	383	430	484	546
current consumption	[A]	2	2,1	2,2	2,3	2,5	2,7	2,9

ambient temperature	[°C / °F]	32 / 90 (suction gas temperature [°C / °F]: 20 / 68, subcooling: 2K)						
evaporating temperature	[°C / °F]	-15 / 5	-10 / 14	-6,7 / 20	-5 / 23	0 / 32	5 / 41	10 / 50
cooling capacity	[W]	500	600	671	709	825	948	1077
COP	[W/W]	1,59	1,69	1,74	1,76	1,81	1,84	1,83
cooling capacity	[Btu/h]	1708	2049	2291	2420	2817	3237	3677
power consumption	[W]	315	355	385	402	455	516	587
current consumption	[A]	2	2,2	2,3	2,3	2,6	2,8	3,1

ambient temperature	[°C / °F]	38 / 100 (suction gas temperature [°C / °F]: 20 / 68, subcooling: 2K)						
evaporating temperature	[°C / °F]	-15 / 5	-10 / 14	-6,7 / 20	-5 / 23	0 / 32	5 / 41	
cooling capacity	[W]	450	541	605	640	747	862	
COP	[W/W]	1,39	1,48	1,52	1,54	1,58	1,6	
cooling capacity	[Btu/h]	1538	1847	2068	2186	2551	2944	
power consumption	[W]	323	366	398	416	473	540	
current consumption	[A]	2	2,2	2,3	2,4	2,6	2,9	

ambient temperature	[°C / °F]	43 / 109 (suction gas temperature [°C / °F]: 20 / 68, subcooling: 2K)						
evaporating temperature	[°C / °F]	-15 / 5	-10 / 14	-6,7 / 20	-5 / 23	0 / 32		
cooling capacity	[W]	409	493	553	586	687		
COP	[W/W]	1,25	1,33	1,37	1,38	1,42		
cooling capacity	[Btu/h]	1396	1683	1889	2001	2346		
power consumption	[W]	326	371	405	424	485		
current consumption	[A]	2,1	2,2	2,4	2,4	2,7		