

Model

Designation

CU NLE12.6CNL R290 230/1/50 CAF



Sales code:

314H5002

Engineering code:

CUNLE126CNLCE

Application Data

Power supply	220-240V / 50Hz 1~
Refrigerants	R290
Refr. charge - tech. limit	150g / 5,3oz
Starter	HST / capillary tube or expansion valve
Sound pressure (10m)	28dB(A)

Generic data

Voltage range	198 - 254V / 50Hz
Refrigerant	R290
Application	LBP
Rated performance	<u>pe=-25°C, Tsuc=20°C, Tamb=25°C, subccoling: 2K</u>
Cooling capacity	582W / 1988Btu/h
Power consumption	345W
Current consumption	2,1A
COP/EER	1,69 / 5,76Btu/Wh
Approvals	Eco design (EU) 2015/1095, CE, UK CA, VDE

Compressor

Designation	NLE12.6CNL
Motor configuration	CSIR
Locked rotor amperage	12,5A
Rated load amperage	2,56A
Winding resistance main	5,64Ω
Winding resistance aux	8,49Ω
Oil quantity	300cm ³ / 10,1fl.oz
Oil type	POE
Horsepower rating	3/5 HP

Dimensions

Condensing unit

Height x Width x Depth	272 x 300 x 380 [mm] / 10,7 x 11,8 x 15 [in]
Weight	17,6kg / 38,8lbs
Suction adapter	OD ø8mm / 1/3in
Discharge adapter	OD ø6mm / 1/4in
Process connector	ø6,2mm / 0,24in

Package data

Height x Width x Depth	300 x 340 x 494 [mm] / 11,8 x 13,4 x 19,4 [in]
Weight	20,6kg / 45,4lbs

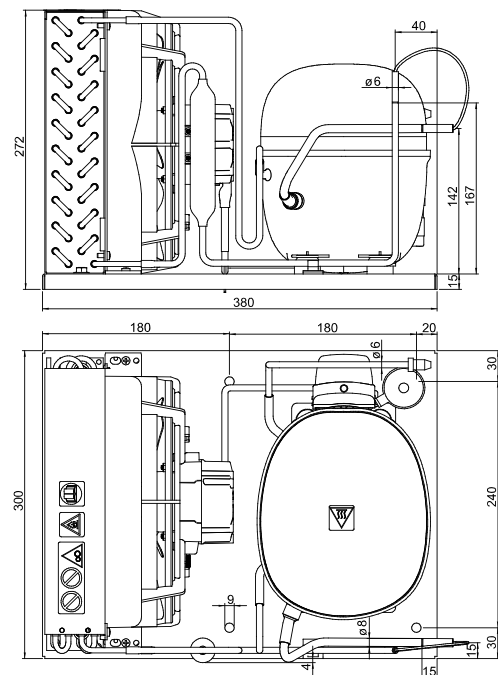

Model

Designation **CU NLE12.6CNL R290 230/1/50 CAF**

Sales code: 314H5002
Engineering code: CUNLE126CNLCE

Components Condensing-Unit / Spare Parts

Component	Type	Spare part code number
Compressor code	NLE12.6CNL	105H6378
Condenser	Condenser (4 rows x 10 tubes)	1040240F10
Fan motor	14W	62010150
Blade code	ø230mm 28°	A230-28
Air flow	435,2m³/h	
Receiver code	not installed	-/-
Suction valve code	OD ø8mm / 1/3in	-/-
Liquid valve code	OD ø6mm / 1/4in	-/-

Compressor starting equipment	Spare part code number
pos. a2 - relay	117U7003
pos. c - start capacitor (80µF)	117U5015
pos. b - plastic cover	103N2010
pos. d - cord relief	103N1010

Wiring Sketch Compressor

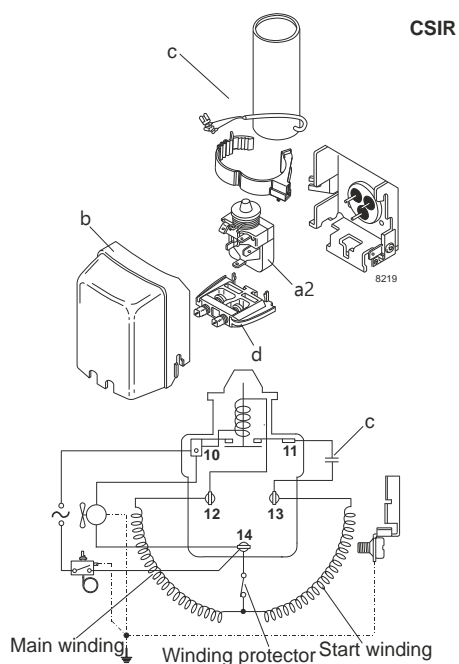

Model

Designation **CU NLE12.6CNL R290 230/1/50 CAF**

Sales code: 314H5002

Engineering code: CUNLE126CNLCE

Cooling performance - Conf. 1

Power supply 220-240V / 50Hz 1~ Voltage range 198 - 254V / 50Hz

Refr. charge - tech. limit 150g / 5,3oz

Starter HST / capillary tube or expansion valve

Motor configuration CSIR

Refrigerant R290

Application LBP

Approvals Eco design (EU) 2015/1095, CE, UK CA, VDE

ambient temperature	[°C / °F]	25 / 77							(suction gas temperature [°C / °F]: 20 / 68, subcooling: 2K)
evaporating temperature	[°C / °F]	-40 / -40	-35 / -31	-30 / -22	-25 / -13	-20 / -4	-10 / 14	-5 / 23	
cooling capacity	[W]	312	393	483	582	693	950	1096	
COP	[W/W]	1,27	1,41	1,55	1,69	1,81	2	2,04	
cooling capacity	[Btu/h]	1066	1343	1648	1988	2366	3244	3742	
power consumption	[W]	245	278	311	345	382	476	538	
current consumption	[A]	1,8	1,9	2	2,1	2,3	2,7	2,9	

ambient temperature	[°C / °F]	32 / 90							(suction gas temperature [°C / °F]: 20 / 68, subcooling: 2K)
evaporating temperature	[°C / °F]	-40 / -40	-35 / -31	-30 / -22	-25 / -13	-20 / -4	-10 / 14	-5 / 23	
cooling capacity	[W]	278	353	435	527	629	865	1000	
COP	[W/W]	1,14	1,26	1,37	1,48	1,58	1,72	1,75	
cooling capacity	[Btu/h]	949	1205	1487	1800	2147	2956	3416	
power consumption	[W]	244	281	317	356	398	504	572	
current consumption	[A]	1,8	1,9	2,1	2,2	2,4	2,8	3,1	

ambient temperature	[°C / °F]	38 / 100							(suction gas temperature [°C / °F]: 20 / 68, subcooling: 2K)
evaporating temperature	[°C / °F]	-40 / -40	-35 / -31	-30 / -22	-25 / -13	-20 / -4	-10 / 14	-5 / 23	
cooling capacity	[W]	253	323	399	484	578	796	920	
COP	[W/W]	1,02	1,13	1,22	1,32	1,4	1,51	1,53	
cooling capacity	[Btu/h]	864	1103	1364	1652	1972	2719	3143	
power consumption	[W]	248	287	326	368	414	528	600	
current consumption	[A]	1,9	2	2,1	2,2	2,4	2,9	3,2	

ambient temperature	[°C / °F]	43 / 109							(suction gas temperature [°C / °F]: 20 / 68, subcooling: 2K)
evaporating temperature	[°C / °F]	-40 / -40	-35 / -31	-30 / -22	-25 / -13	-20 / -4	-10 / 14	-5 / 23	
cooling capacity	[W]	233	299	370	449	536	739	854	
COP	[W/W]	0,93	1,03	1,11	1,19	1,26	1,36	1,38	
cooling capacity	[Btu/h]	796	1021	1264	1532	1830	2522	2917	
power consumption	[W]	251	291	332	376	425	544	618	
current consumption	[A]	1,9	2	2,1	2,3	2,5	3	3,3	