

## Model

Designation **CU NLE12.6MN R290 230/1/50 CAP**



Sales code: 314H5003  
Engineering code: CUNLE126MNCE

## Application Data

Power supply 220-240V / 50Hz 1~  
Refrigerants R290  
Refr. charge - tech. limit 150g / 5,3oz  
Starter HST / capillary tube or expansion valve  
Sound pressure (10m) 31,9dB(A)

## Generic data

Voltage range 198 - 254V / 50Hz  
Refrigerant R290  
Application MBP  
  
Rated performance pe=-10°C, Tsuc=20°C, Tamb=25°C, subcooling: 2K  
Cooling capacity 996W / 3403Btu/h  
Power consumption 468,9W  
Current consumption 2,8A  
COP/EER 2,12 / 7,26Btu/Wh  
  
Approvals Eco design (EU) 2015/1095,  
CE, UK CA, VDE

## Compressor

Designation **NLE12.6MN**  
Motor configuration CSIR  
Locked rotor amperage 14,4A  
Rated load amperage 2,98A  
Winding resistance main 4,74Ω  
Winding resistance aux 7,92Ω  
Oil quantity 300cm<sup>3</sup> / 10,1fl.oz  
Oil type POE  
Horsepower rating 3/5 HP

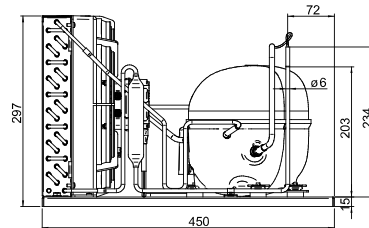

## Dimensions

### Condensing unit

Height x Width x Depth 297 x 350 x 450 [mm] / 11,7 x 13,8 x 17,7 [in]  
Weight 19,6kg / 43,2lbs  
Suction adapter OD ø8mm / 1/3in  
Discharge adapter OD ø6mm / 1/4in  
Process connector ø6,2mm / 0,24in

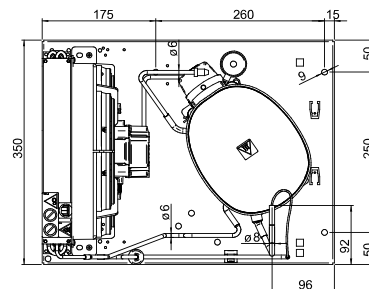

### Package data

Height x Width x Depth 340 x 372 x 570 [mm] / 13,4 x 14,6 x 22,4 [in]  
Weight 22,6kg / 49,8lbs

### Model

Designation **CU NLE12.6MN R290 230/1/50 CAP**

Sales code: 314H5003  
Engineering code: CUNLE126MNCE

### Components Condensing-Unit / Spare Parts

Component	Type	Spare part code number
Compressor code	NLE12.6MN	105H6377
Condenser	Condenser (3 rows x 11 tubes)	1130270FI0
Fan motor		62010155
Blade code	ø254mm 28°	A254-28
Air flow	674,9m³/h	
Receiver code	not installed	-/-
Suction valve code	OD ø8mm / 1/3in	-/-
Liquid valve code	OD ø6mm / 1/4in	-/-

Compressor starting equipment	Spare part code number
pos. a2 - relay	117U7011
pos. c - start capacitor (80µF)	117U5015
pos. b - plastic cover	103N2010
pos. d - cord relief	103N1010

### Wiring Sketch Compressor

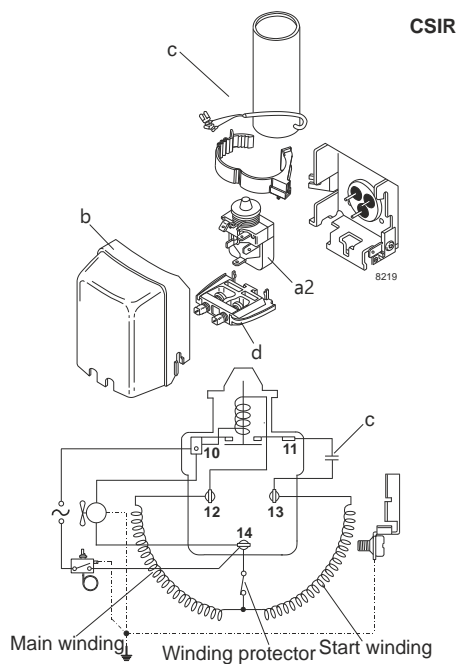

## Model

Designation	<b>CU NLE12.6MN R290 230/1/50 CAP</b>	Sales code:	314H5003
		Engineering code:	CUNLE126MNCE

## Cooling performance - Conf. 1

Power supply	220-240V / 50Hz 1~	Voltage range	198 - 254V / 50Hz
Refr. charge - tech. limit	150g / 5,3oz		
Starter	HST / capillary tube or expansion valve		
Motor configuration	CSIR		
Refrigerant	R290		
Application	MBP		
Approvals	Eco design (EU) 2015/1095, CE, UK CA, VDE		

<b>ambient temperature</b>	<b>[°C / °F]</b>	<b>25 / 77</b> (suction gas temperature [°C / °F]: 20 / 68, subcooling: 2K)						
evaporating temperature	[°C / °F]	-25 / -13	-20 / -4	-15 / 5	-10 / 14	0 / 32	5 / 41	10 / 50
cooling capacity	[W]	590	712	848	996	1323	1496	1671
COP	[W/W]	1,69	1,84	1,99	2,12	2,32	2,36	2,35
cooling capacity	[Btu/h]	2015	2430	2895	3403	4518	5109	5707
power consumption	[W]	350	388	427	469	571	635	712
current consumption	[A]	2,4	2,5	2,7	2,8	3,2	3,5	3,9

<b>ambient temperature</b>	<b>[°C / °F]</b>	<b>32 / 90</b> (suction gas temperature [°C / °F]: 20 / 68, subcooling: 2K)						
evaporating temperature	[°C / °F]	-25 / -13	-20 / -4	-15 / 5	-10 / 14	0 / 32	5 / 41	10 / 50
cooling capacity	[W]	541	650	771	905	1199	1355	1512
COP	[W/W]	1,49	1,61	1,72	1,82	1,95	1,96	1,93
cooling capacity	[Btu/h]	1846	2218	2635	3091	4095	4627	5164
power consumption	[W]	362	403	447	496	616	692	782
current consumption	[A]	2,5	2,6	2,8	2,9	3,4	3,8	4,2

<b>ambient temperature</b>	<b>[°C / °F]</b>	<b>38 / 100</b> (suction gas temperature [°C / °F]: 20 / 68, subcooling: 2K)						
evaporating temperature	[°C / °F]	-25 / -13	-20 / -4	-15 / 5	-10 / 14	0 / 32	5 / 41	
cooling capacity	[W]	493	593	705	827	1097	1239	
COP	[W/W]	1,31	1,42	1,51	1,59	1,67	1,67	
cooling capacity	[Btu/h]	1683	2024	2406	2824	3745	4231	
power consumption	[W]	375	418	466	521	656	742	
current consumption	[A]	2,5	2,7	2,8	3,1	3,6	4	

<b>ambient temperature</b>	<b>[°C / °F]</b>	<b>43 / 109</b> (suction gas temperature [°C / °F]: 20 / 68, subcooling: 2K)						
evaporating temperature	[°C / °F]	-25 / -13	-20 / -4	-15 / 5	-10 / 14	0 / 32		
cooling capacity	[W]	453	547	651	766	1017		
COP	[W/W]	1,18	1,27	1,35	1,42	1,48		
cooling capacity	[Btu/h]	1548	1868	2225	2615	3473		
power consumption	[W]	385	430	482	541	689		
current consumption	[A]	2,6	2,7	2,9	3,1	3,7		