

Model

Designation **CU SC10MLX MG_Z 230/1/50 CAP**



Sales code: 314L4008
Engineering code: CUSC10MLX00CE

Application Data

Power supply	220-240V / 50Hz 1~
Refrigerants	R404A-R452A-R449A
Refr. charge - tech. limit	1300g / 45,9oz
Starter	HST / capillary tube or expansion valve
Sound pressure (10m)	36,5dB(A)

Configuration data

	Conf. 1	Conf. 2	Conf. 3
Voltage range	187 - 254V / 50Hz	187 - 254V / 50Hz	187 - 254V / 50Hz
Refrigerant	R404A	R452A	R449A
Application	MBP	MBP	MBP
Rated performance	<u>pe=-10°C, Tsuc=20°C, Tamb=25°C, subcooling: 2K</u>		
Cooling capacity	882W / 3012Btu/h	840W / 2870Btu/h	816W / 2785Btu/h
Power consumption	522,4W	495,2W	471,8W
Current consumption	3,7A	3,7A	3,6A
COP/EER	1,69 / 5,77Btu/Wh	1,7 / 5,8Btu/Wh	1,73 / 5,9Btu/Wh
Approvals	Eco design (EU) 2015/1095, CE, UK CA, VDE	Eco design (EU) 2015/1095, CE, UK CA, VDE	Eco design (EU) 2015/1095, CE

Compressor

Designation	SC10MLX
Motor configuration	CSIR
Locked rotor amperage	19A
Rated load amperage	3,9A
Winding resistance main	4,4Ω
Winding resistance aux	14Ω
Oil quantity	550cm ³ / 18,6fl.oz
Oil type	POE
Horsepower rating	1/2 HP

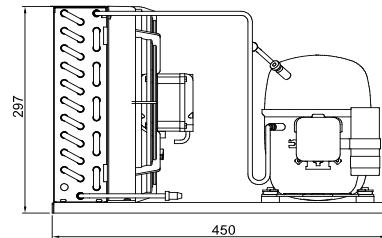

Dimensions

Condensing unit

Height x Width x Depth	297 x 350 x 450 [mm] / 11,7 x 13,8 x 17,7 [in]
Weight	19,5kg / 42,9lbs
Suction adapter	OD ø8mm / 1/3in
Discharge adapter	OD ø6mm / 1/4in
Process connector	ø6,5mm / 0,26in

Package data

Height x Width x Depth	350 x 450 x 550 [mm] / 13,8 x 17,7 x 21,7 [in]
Weight	22,5kg / 49,5lbs

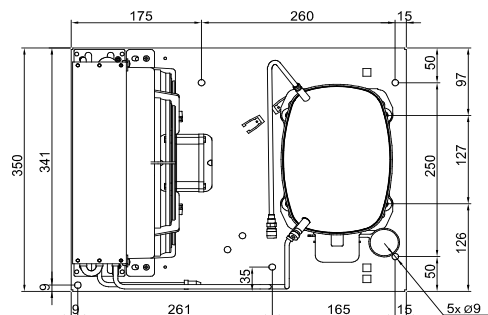

Model

Designation **CU SC10MLX MG_Z 230/1/50 CAP**

Sales code: 314L4008
Engineering code: CUSC10MLX00CE

Components Condensing-Unit / Spare Parts

Component	Type	Spare part code number
Compressor code	SC10MLX	104L2506
Condenser	Condenser (3 rows x 11 tubes)	1130270F70
Fan motor	16W	NET3T16PVN018
Blade code	ø254mm 22°	A254-22
Air flow	631,8m³/h	
Receiver code	not installed	-/-
Suction valve code	OD ø8mm / 1/3in	-/-
Liquid valve code	OD ø6mm / 1/4in	-/-

Compressor starting equipment	Spare part code number
pos. a2 - relay	117U6011
pos. c - start capacitor (80µF)	117U5017
pos. d - cord relief	103N1004
pos. b - plastic cover	103N2008

Wiring Sketch Compressor

Wiring Sketch Condensing Unit

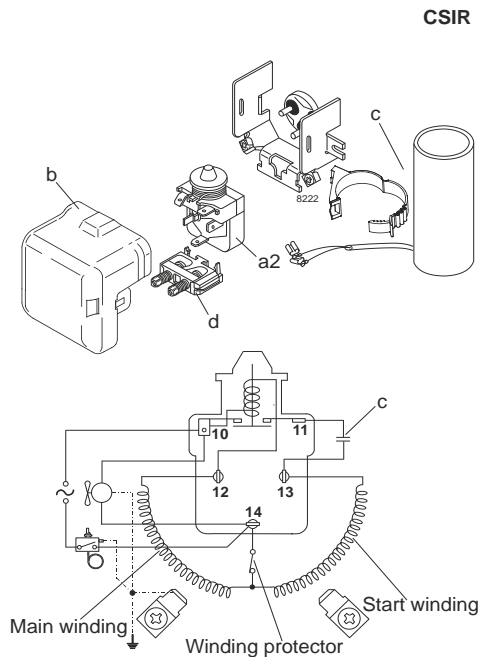

Model

Designation **CU SC10MLX MG_Z 230/1/50 CAP**

Sales code: 314L4008

Engineering code: CUSC10MLX00CE

Cooling performance - Conf. 1

Power supply	220-240V / 50Hz 1~	Voltage range	187 - 254V / 50Hz
Refr. charge - tech. limit	1300g / 45,9oz		
Starter	HST / capillary tube or expansion valve		
Motor configuration	CSIR		
Refrigerant	R404A		
Application	MBP		
Approvals	Eco design (EU) 2015/1095, CE, UK CA, VDE		

ambient temperature	[°C / °F]	25 / 77 (suction gas temperature [°C / °F]: 20 / 68, subcooling: 2K)						
evaporating temperature	[°C / °F]	-20 / -4	-15 / 5	-10 / 14	-5 / 23	0 / 32	5 / 41	10 / 50
cooling capacity	[W]	617	743	882	1031	1186	1343	1500
COP	[W/W]	1,4	1,55	1,69	1,81	1,91	1,99	2,05
cooling capacity	[Btu/h]	2106	2536	3011	3521	4050	4588	5124
power consumption	[W]	440	479	522	569	620	675	733
current consumption	[A]	3,4	3,5	3,7	3,9	4,1	4,3	4,6

ambient temperature	[°C / °F]	32 / 90 (suction gas temperature [°C / °F]: 20 / 68, subcooling: 2K)						
evaporating temperature	[°C / °F]	-20 / -4	-15 / 5	-10 / 14	-5 / 23	0 / 32	5 / 41	
cooling capacity	[W]	540	651	773	902	1036	1171	
COP	[W/W]	1,18	1,3	1,41	1,51	1,59	1,65	
cooling capacity	[Btu/h]	1843	2225	2641	3082	3539	4000	
power consumption	[W]	456	500	547	598	652	710	
current consumption	[A]	3,5	3,6	3,8	4	4,2	4,5	

ambient temperature	[°C / °F]	38 / 100 (suction gas temperature [°C / °F]: 20 / 68, subcooling: 2K)		
evaporating temperature	[°C / °F]	-20 / -4	-15 / 5	-10 / 14
cooling capacity	[W]	472	571	678
COP	[W/W]	1,01	1,1	1,19
cooling capacity	[Btu/h]	1611	1950	2315
power consumption	[W]	468	517	568
current consumption	[A]	3,5	3,7	3,8

ambient temperature	[°C / °F]	43 / 109 (suction gas temperature [°C / °F]: 20 / 68, subcooling: 2K)
evaporating temperature	[°C / °F]	-20 / -4
cooling capacity	[W]	413
COP	[W/W]	0,87
cooling capacity	[Btu/h]	1412
power consumption	[W]	476
current consumption	[A]	3,5

Model

Designation **CU SC10MLX MG_Z 230/1/50 CAP**

Sales code: 314L4008

Engineering code: CUSC10MLX00CE

Cooling performance - Conf. 2

Power supply	220-240V / 50Hz 1~	Voltage range	187 - 254V / 50Hz
Refr. charge - tech. limit	1300g / 45,9oz		
Starter	HST / capillary tube or expansion valve		
Motor configuration	CSIR		
Refrigerant	R452A		
Application	MBP		
Approvals	Eco design (EU) 2015/1095, CE, UK CA, VDE		

ambient temperature	[°C / °F]	25 / 77 (suction gas temperature [°C / °F]: 20 / 68, subcooling: 2K)						
evaporating temperature	[°C / °F]	-20 / -4	-15 / 5	-10 / 14	-5 / 23	0 / 32	5 / 41	10 / 50
cooling capacity	[W]	577	702	840	990	1146	1308	1469
COP	[W/W]	1,4	1,55	1,7	1,83	1,93	2,01	2,07
cooling capacity	[Btu/h]	1972	2396	2870	3380	3915	4466	5015
power consumption	[W]	413	452	495	542	594	650	711
current consumption	[A]	3,4	3,5	3,7	3,8	4	4,2	4,5

ambient temperature	[°C / °F]	32 / 90 (suction gas temperature [°C / °F]: 20 / 68, subcooling: 2K)						
evaporating temperature	[°C / °F]	-20 / -4	-15 / 5	-10 / 14	-5 / 23	0 / 32	5 / 41	
cooling capacity	[W]	506	617	739	869	1006	1145	
COP	[W/W]	1,18	1,31	1,43	1,53	1,61	1,67	
cooling capacity	[Btu/h]	1728	2107	2523	2969	3435	3910	
power consumption	[W]	428	471	518	569	624	684	
current consumption	[A]	3,4	3,6	3,7	3,9	4,1	4,4	

ambient temperature	[°C / °F]	38 / 100 (suction gas temperature [°C / °F]: 20 / 68, subcooling: 2K)			
evaporating temperature	[°C / °F]	-20 / -4	-15 / 5	-10 / 14	-5 / 23
cooling capacity	[W]	444	542	650	764
COP	[W/W]	1,01	1,12	1,21	1,29
cooling capacity	[Btu/h]	1515	1852	2220	2610
power consumption	[W]	438	486	537	593
current consumption	[A]	3,4	3,6	3,8	4

ambient temperature	[°C / °F]	43 / 109 (suction gas temperature [°C / °F]: 20 / 68, subcooling: 2K)
evaporating temperature	[°C / °F]	-20 / -4
cooling capacity	[W]	389
COP	[W/W]	0,87
cooling capacity	[Btu/h]	1330
power consumption	[W]	445
current consumption	[A]	3,5

Model

Designation **CU SC10MLX MG_Z 230/1/50 CAP**

Sales code: 314L4008

Engineering code: CUSC10MLX00CE

Cooling performance - Conf. 3

Power supply	220-240V / 50Hz 1~	Voltage range	187 - 254V / 50Hz
Refr. charge - tech. limit	1300g / 45,9oz		
Starter	HST / capillary tube or expansion valve		
Motor configuration	CSIR		
Refrigerant	R449A		
Application	MBP		
Approvals	Eco design (EU) 2015/1095, CE		

ambient temperature	[°C / °F]	25 / 77 (suction gas temperature [°C / °F]: 20 / 68, subcooling: 2K)						
evaporating temperature	[°C / °F]	-15 / 5	-10 / 14	-6,7 / 20	-5 / 23	0 / 32	5 / 41	10 / 50
cooling capacity	[W]	674	816	917	971	1136	1310	1487
COP	[W/W]	1,57	1,73	1,83	1,87	2	2,09	2,16
cooling capacity	[Btu/h]	2303	2785	3130	3316	3881	4475	5079
power consumption	[W]	430	472	502	518	569	626	688
current consumption	[A]	3,5	3,6	3,7	3,8	3,9	4,1	4,3

ambient temperature	[°C / °F]	32 / 90 (suction gas temperature [°C / °F]: 20 / 68, subcooling: 2K)						
evaporating temperature	[°C / °F]	-15 / 5	-10 / 14	-6,7 / 20	-5 / 23	0 / 32	5 / 41	
cooling capacity	[W]	600	727	816	864	1011	1164	
COP	[W/W]	1,34	1,47	1,55	1,59	1,68	1,76	
cooling capacity	[Btu/h]	2050	2481	2788	2952	3454	3976	
power consumption	[W]	449	495	528	545	601	661	
current consumption	[A]	3,5	3,7	3,8	3,9	4	4,2	

ambient temperature	[°C / °F]	38 / 100 (suction gas temperature [°C / °F]: 20 / 68, subcooling: 2K)			
evaporating temperature	[°C / °F]	-15 / 5	-10 / 14	-6,7 / 20	-5 / 23
cooling capacity	[W]	535	648	729	771
COP	[W/W]	1,15	1,26	1,33	1,36
cooling capacity	[Btu/h]	1827	2214	2488	2635
power consumption	[W]	465	515	550	569
current consumption	[A]	3,6	3,8	3,9	3,9

ambient temperature	[°C / °F]	43 / 109 (suction gas temperature [°C / °F]: 20 / 68, subcooling: 2K)
evaporating temperature	[°C / °F]	-15 / 5
cooling capacity	[W]	479
COP	[W/W]	1
cooling capacity	[Btu/h]	1635
power consumption	[W]	477
current consumption	[A]	3,6