

Model

Designation **CU SC12MLX MG_Z 230/1/50 VAL**



Sales code: 314L4011
Engineering code: CUSC12MLX00VE

Application Data

Power supply 220-240V / 50Hz 1~
Refrigerants R404A-R452A-R449A
Refr. charge - tech. limit 1300g / 45,9oz
Starter HST / capillary tube or expansion valve
Sound pressure (10m) 33,6dB(A)

Configuration data

	Conf. 1	Conf. 2	Conf. 3
Voltage range	187 - 254V / 50Hz	187 - 254V / 50Hz	187 - 254V / 50Hz
Refrigerant	R404A	R452A	R449A
Application	MBP	MBP	MBP
Rated performance	<u>pe=-10°C, Tsuc=20°C, Tamb=25°C, subccoling: 2K</u>		
Cooling capacity	1088W / 3715Btu/h	1037W / 3541Btu/h	1005W / 3431Btu/h
Power consumption	614,9W	584,7W	550,1W
Current consumption	4,1A	4A	3,9A
COP/EER	1,77 / 6,04Btu/Wh	1,77 / 6,06Btu/Wh	1,83 / 6,24Btu/Wh
Approvals	CE, UK CA, VDE	CE, UK CA, VDE	CE

Compressor

Designation **SC12MLX**
Motor configuration CSIR
Locked rotor amperage 23,4A
Rated load amperage 4,3A
Winding resistance main 3,4Ω
Winding resistance aux 14,4Ω
Oil quantity 550cm³ / 18,6fl.oz
Oil type POE
Horsepower rating 1/2 HP

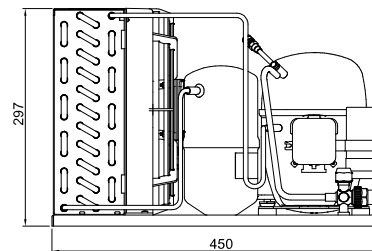

Dimensions

Condensing unit

Height x Width x Depth 297 x 350 x 450 [mm] / 11,7 x 13,8 x 17,7 [in]
Weight 21,5kg / 47,5lbs
Suction adapter FLARE 1/4"
Discharge adapter FLARE 1/4"
Process connector ø6,5mm / 0,26in

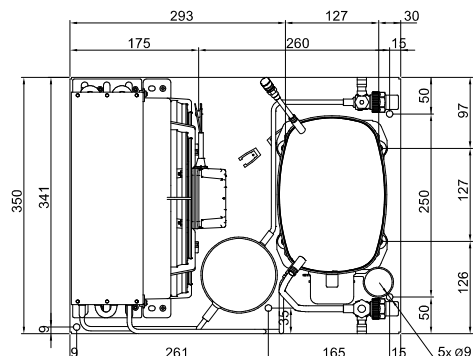

Package data

Height x Width x Depth 350 x 450 x 550 [mm] / 13,8 x 17,7 x 21,7 [in]
Weight 24,5kg / 54,1lbs

Model

Designation **CU SC12MLX MG_Z 230/1/50 VAL**

Sales code: 314L4011

Engineering code: CUSC12MLX00VE

Components Condensing-Unit / Spare Parts

Component	Type	Spare part code number
Compressor code	SC12MLX	104L2606
Condenser	Condenser (4 rows x 11 tubes)	1140270F71
Fan motor		62010155
Blade code	ø254mm 28°	A254-28
Air flow	576,9m³/h	
Receiver code	Receiver 1,3 liter	100/200VS00
Suction valve code	FLARE 1/4"	FLARE 1/4"
Liquid valve code	FLARE 1/4"	FLARE 1/4"

Compressor starting equipment	Spare part code number
pos. a2 - relay	117U6011
pos. c - start capacitor (80µF)	117U5017
pos. d - cord relief	103N1004
pos. b - plastic cover	103N2008

Wiring Sketch Compressor

Wiring Sketch Condensing Unit

CSIR

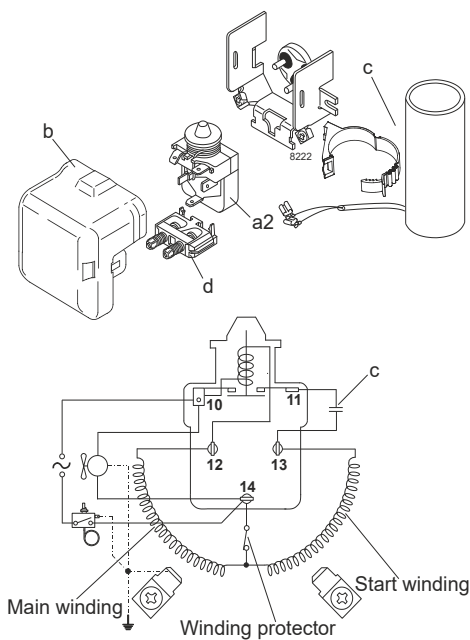

Model

Designation	CU SC12MLX MG_Z 230/1/50 VAL	Sales code:	314L4011
		Engineering code:	CUSC12MLX00VE

Cooling performance - Conf. 1

Power supply	220-240V / 50Hz 1~	Voltage range	187 - 254V / 50Hz
Refr. charge - tech. limit	1300g / 45,9oz		
Starter	HST / capillary tube or expansion valve		
Motor configuration	CSIR		
Refrigerant	R404A		
Application	MBP		
Approvals	CE, UK CA, VDE		

ambient temperature	[°C / °F]	25 / 77							(suction gas temperature [°C / °F]: 20 / 68, subcooling: 2K)
evaporating temperature	[°C / °F]	-25 / -13	-20 / -4	-15 / 5	-10 / 14	0 / 32	5 / 41	10 / 50	
cooling capacity	[W]	628	762	917	1087	1465	1662	1859	
COP	[W/W]	1,34	1,48	1,63	1,77	2	2,08	2,13	
cooling capacity	[Btu/h]	2146	2604	3131	3714	5002	5675	6350	
power consumption	[W]	469	514	562	615	733	800	871	
current consumption	[A]	3,7	3,8	3,9	4,1	4,6	4,9	5,2	

ambient temperature	[°C / °F]	32 / 90							(suction gas temperature [°C / °F]: 20 / 68, subcooling: 2K)
evaporating temperature	CE, / °F]	-25 / -13	-20 / -4	-15 / 5	-10 / 14	CE	5 / 41		
cooling capacity	[W]	550	670	807	957	1283	1453		
COP	[W/W]	1,13	1,25	1,37	1,48	1,66	1,72		
cooling capacity	[Btu/h]	1879	2290	2756	3267	4383	4963		
power consumption	[W]	485	535	589	646	773	844		
current consumption	[A]	3,7	3,8	4	4,2	4,7	5		

ambient temperature	[°C / °F]	38 / 100				(suction gas temperature [°C / °F]: 20 / 68, subcooling: 2K)
evaporating temperature	[°C / °F]	-25 / -13	-20 / -4	-15 / 5	-10 / 14	
cooling capacity	[W]	480	589	710	842	
COP	[W/W]	0,97	1,07	1,16	1,25	
cooling capacity	[Btu/h]	1641	2012	2425	2877	
power consumption	[W]	495	551	610	672	
current consumption	[A]	3,7	3,9	4,1	4,3	

ambient temperature	[°C / °F]	43 / 109		(suction gas temperature [°C / °F]: 20 / 68, subcooling: 2K)
evaporating temperature	[°C / °F]	-25 / -13	-20 / -4	
cooling capacity	[W]	420	519	
COP	[W/W]	0,84	0,93	
cooling capacity	[Btu/h]	1435	1772	
power consumption	[W]	499	561	
current consumption	[A]	3,7	3,9	

Model

Designation	CU SC12MLX MG_Z 230/1/50 VAL	Sales code:	314L4011
		Engineering code:	CUSC12MLX00VE

Cooling performance - Conf. 2

Power supply	220-240V / 50Hz 1~	Voltage range	187 - 254V / 50Hz
Refr. charge - tech. limit	1300g / 45,9oz		
Starter	HST / capillary tube or expansion valve		
Motor configuration	CSIR		
Refrigerant	R452A		
Application	MBP		
Approvals	CE, UK CA, VDE		

ambient temperature	[°C / °F]	25 / 77							(suction gas temperature [°C / °F]: 20 / 68, subcooling: 2K)
evaporating temperature	[°C / °F]	-25 / -13	-20 / -4	-15 / 5	-10 / 14	0 / 32	5 / 41	10 / 50	
cooling capacity	[W]	585	716	867	1037	1416	1616	1819	
COP	[W/W]	1,33	1,48	1,63	1,77	2,01	2,1	2,16	
cooling capacity	[Btu/h]	1998	2444	2962	3540	4834	5520	6214	
power consumption	[W]	441	485	533	585	704	771	844	
current consumption	[A]	3,6	3,7	3,9	4	4,4	4,6	4,9	

ambient temperature	[°C / °F]	32 / 90							(suction gas temperature [°C / °F]: 20 / 68, subcooling: 2K)
evaporating temperature	CE, / °F]	-25 / -13	-20 / -4	-15 / 5	-10 / 14	CE	5 / 41		
cooling capacity	[W]	513	631	765	915	1246	1420		
COP	[W/W]	1,13	1,25	1,37	1,49	1,68	1,74		
cooling capacity	[Btu/h]	1751	2154	2613	3126	4255	4849		
power consumption	[W]	455	504	557	614	743	815		
current consumption	[A]	3,6	3,8	4	4,1	4,5	4,8		

ambient temperature	[°C / °F]	38 / 100				(suction gas temperature [°C / °F]: 20 / 68, subcooling: 2K)
evaporating temperature	[°C / °F]	-25 / -13	-20 / -4	-15 / 5	-10 / 14	
cooling capacity	[W]	449	556	676	808	
COP	[W/W]	0,97	1,07	1,17	1,26	
cooling capacity	[Btu/h]	1533	1897	2309	2761	
power consumption	[W]	464	519	577	640	
current consumption	[A]	3,7	3,8	4	4,2	

ambient temperature	[°C / °F]	43 / 109			(suction gas temperature [°C / °F]: 20 / 68, subcooling: 2K)
evaporating temperature	[°C / °F]	-25 / -13	-20 / -4	-15 / 5	
cooling capacity	[W]	394	491	599	
COP	[W/W]	0,84	0,93	1,01	
cooling capacity	[Btu/h]	1344	1677	2047	
power consumption	[W]	468	529	592	
current consumption	[A]	3,7	3,9	4,1	

Model

Designation	CU SC12MLX MG_Z 230/1/50 VAL	Sales code:	314L4011
		Engineering code:	CUSC12MLX00VE

Cooling performance - Conf. 3

Power supply	220-240V / 50Hz 1~	Voltage range	187 - 254V / 50Hz
Refr. charge - tech. limit	1300g / 45,9oz		
Starter	HST / capillary tube or expansion valve		
Motor configuration	CSIR		
Refrigerant	R449A		
Application	MBP		
Approvals	CE		

ambient temperature	[°C / °F]	25 / 77							(suction gas temperature [°C / °F]: 20 / 68, subcooling: 2K)
evaporating temperature	[°C / °F]	-20 / -4	-15 / 5	-10 / 14	-5 / 23	0 / 32	5 / 41	10 / 50	
cooling capacity	[W]	679	831	1004	1195	1401	1617	1840	
COP	[W/W]	1,5	1,67	1,83	1,97	2,1	2,2	2,27	
cooling capacity	[Btu/h]	2318	2839	3430	4083	4785	5523	6283	
power consumption	[W]	452	499	550	606	668	736	810	
current consumption	[A]	3,6	3,7	3,9	4,1	4,3	4,6	4,8	

ambient temperature	[°C / °F]	32 / 90							(suction gas temperature [°C / °F]: 20 / 68, subcooling: 2K)
evaporating temperature	CE, / °F]	-20 / -4	-15 / 5	-10 / 14	-5 / 23	CE	5 / 41		
cooling capacity	[W]	605	742	898	1068	1250	1442		
COP	[W/W]	1,28	1,42	1,55	1,67	1,77	1,85		
cooling capacity	[Btu/h]	2067	2536	3066	3647	4269	4924		
power consumption	[W]	471	523	579	640	707	779		
current consumption	[A]	3,6	3,8	4	4,2	4,5	4,7		

ambient temperature	[°C / °F]	38 / 100				(suction gas temperature [°C / °F]: 20 / 68, subcooling: 2K)			
evaporating temperature	[°C / °F]	-20 / -4	-15 / 5	-10 / 14	-5 / 23				
cooling capacity	[W]	540	665	804	956				
COP	[W/W]	1,11	1,22	1,33	1,43				
cooling capacity	[Btu/h]	1844	2270	2746	3265				
power consumption	[W]	486	543	604	670				
current consumption	[A]	3,7	3,9	4,1	4,3				

ambient temperature	[°C / °F]	43 / 109		(suction gas temperature [°C / °F]: 20 / 68, subcooling: 2K)					
evaporating temperature	[°C / °F]	-20 / -4	-15 / 5						
cooling capacity	[W]	483	597						
COP	[W/W]	0,97	1,07						
cooling capacity	[Btu/h]	1651	2040						
power consumption	[W]	496	558						
current consumption	[A]	3,7	3,9						