

Model

Designation **CU SC15MFX MG_Y 230/1/50 CAP**



Sales code: 314G4000
Engineering code: CUSC15MFX00CE

Application Data

Power supply	220-240V / 50Hz 1~
Refrigerants	R134a-R513A
Refr. charge - tech. limit	1300g / 45,9oz
Starter	HST / capillary tube or expansion valve
Sound pressure (10m)	37dB(A)

Configuration data

	Conf. 1	Conf. 2
Voltage range	198 - 254V / 50Hz	198 - 254V / 50Hz
Refrigerant	R134a	R513A
Application	MBP	MBP

Rated performance	<u>pe=-10°C, Tsuc=20°C, Tamb=25°C, subccoling: 2K</u>	
Cooling capacity	752W / 2567Btu/h	787W / 2686Btu/h
Power consumption	412,7W	436,7W
Current consumption	2,7A	2,8A
COP/EER	1,82 / 6,22Btu/Wh	1,8 / 6,15Btu/Wh

Approvals	Eco design (EU) 2015/1095, CE, UK CA, VDE	Eco design (EU) 2015/1095, CE, UK CA, VDE
-----------	--	--

Compressor

Designation	SC15MFX
Motor configuration	CSIR
Locked rotor amperage	16,2A
Rated load amperage	3,1A
Winding resistance main	5,13Ω
Winding resistance aux	13,51Ω
Oil quantity	450cm ³ / 15,2fl.oz
Oil type	POE
Horsepower rating	3/10 HP

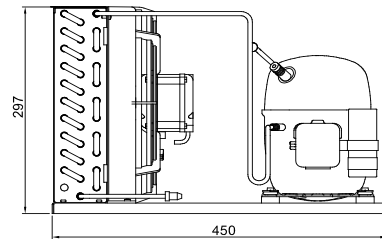

Dimensions

Condensing unit

Height x Width x Depth	297 x 350 x 450 [mm] / 11,7 x 13,8 x 17,7 [in]
Weight	19,5kg / 42,9lbs
Suction adapter	OD ø10mm / 2/5in
Discharge adapter	OD ø6mm / 1/4in
Process connector	ø6,2mm / 0,24in

Package data

Height x Width x Depth	350 x 450 x 550 [mm] / 13,8 x 17,7 x 21,7 [in]
Weight	22,5kg / 49,5lbs

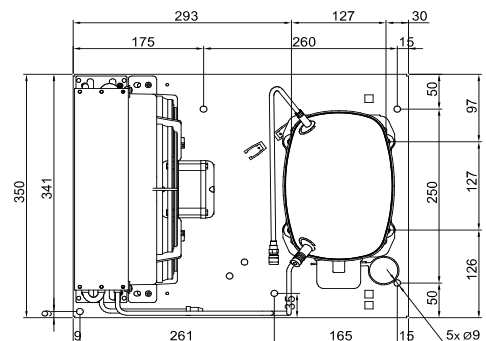

Model

Designation **CU SC15MFX MG_Y 230/1/50 CAP**

Sales code: 314G4000
Engineering code: CUSC15MFX00CE

Components Condensing-Unit / Spare Parts

Component	Type	Spare part code number
Compressor code	SC15MFX	104G8501
Condenser	Condenser (3 rows x 11 tubes)	1130270F70
Fan motor	16W	NET3T16PVN018
Blade code	ø254mm 22°	A254-22
Air flow	631,8m³/h	
Receiver code	not installed	-/-
Suction valve code	OD ø10mm / 2/5in	-/-
Liquid valve code	OD ø6mm / 1/4in	-/-

Compressor starting equipment	Spare part code number
pos. a2 - relay	117U6005
pos. c - start capacitor (80µF)	117U5017
pos. d - cord relief	103N1004
pos. b - plastic cover	103N2008

Wiring Sketch Compressor

Wiring Sketch Condensing Unit

CSIR

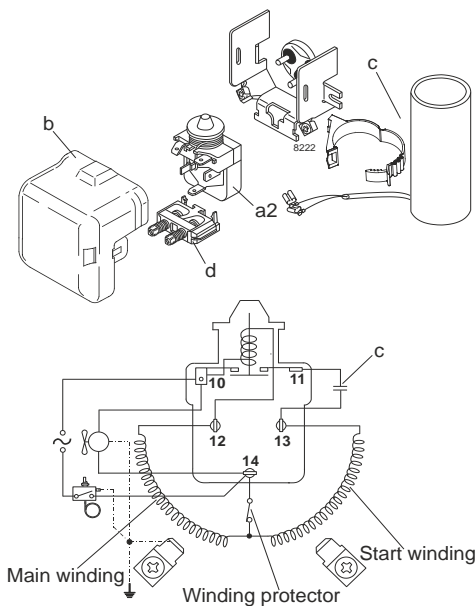

Model

Designation **CU SC15MFX MG_Y 230/1/50 CAP**

Sales code: 314G4000

Engineering code: CUSC15MFX00CE

Cooling performance - Conf. 1

Power supply	220-240V / 50Hz 1~	Voltage range	198 - 254V / 50Hz
Refr. charge - tech. limit	1300g / 45,9oz		
Starter	HST / capillary tube or expansion valve		
Motor configuration	CSIR		
Refrigerant	R134a		
Application	MBP		
Approvals	Eco design (EU) 2015/1095, CE, UK CA, VDE		

ambient temperature	[°C / °F]	25 / 77 (suction gas temperature [°C / °F]: 20 / 68, subcooling: 2K)						
evaporating temperature	[°C / °F]	-25 / -13	-20 / -4	-15 / 5	-10 / 14	0 / 32	5 / 41	10 / 50
cooling capacity	[W]	358	469	601	752	1097	1287	1482
COP	[W/W]	1,24	1,43	1,63	1,82	2,15	2,29	2,39
cooling capacity	[Btu/h]	1221	1603	2054	2567	3748	4394	5062
power consumption	[W]	288	327	369	413	510	563	619
current consumption	[A]	2,4	2,5	2,6	2,7	3,1	3,3	3,5

ambient temperature	[°C / °F]	32 / 90 (suction gas temperature [°C / °F]: 20 / 68, subcooling: 2K)						
evaporating temperature	[°C / °F]	-25 / -13	-20 / -4	-15 / 5	-10 / 14	0 / 32	5 / 41	10 / 50
cooling capacity	[W]	314	421	546	687	1005	1175	1350
COP	[W/W]	1,11	1,28	1,44	1,59	1,85	1,96	2,05
cooling capacity	[Btu/h]	1071	1438	1866	2346	3431	4014	4611
power consumption	[W]	283	330	379	431	542	600	658
current consumption	[A]	2,3	2,5	2,6	2,8	3,2	3,4	3,6

ambient temperature	[°C / °F]	38 / 100 (suction gas temperature [°C / °F]: 20 / 68, subcooling: 2K)						
evaporating temperature	[°C / °F]	-25 / -13	-20 / -4	-15 / 5	-10 / 14	0 / 32	5 / 41	
cooling capacity	[W]	286	388	505	634	922	1075	
COP	[W/W]	1	1,15	1,29	1,42	1,64	1,74	
cooling capacity	[Btu/h]	977	1325	1723	2166	3149	3673	
power consumption	[W]	286	337	391	446	561	619	
current consumption	[A]	2,3	2,5	2,7	2,8	3,2	3,5	

ambient temperature	[°C / °F]	43 / 109 (suction gas temperature [°C / °F]: 20 / 68, subcooling: 2K)						
evaporating temperature	[°C / °F]	-25 / -13	-20 / -4	-15 / 5	-10 / 14	0 / 32		
cooling capacity	[W]	261	357	465	584	847		
COP	[W/W]	0,9	1,04	1,17	1,29	1,49		
cooling capacity	[Btu/h]	893	1220	1590	1996	2892		
power consumption	[W]	291	343	398	454	568		
current consumption	[A]	2,3	2,5	2,7	2,9	3,3		

Model

Designation **CU SC15MFX MG_Y 230/1/50 CAP**

Sales code: 314G4000

Engineering code: CUSC15MFX00CE

Cooling performance - Conf. 2

Power supply	220-240V / 50Hz 1~	Voltage range	198 - 254V / 50Hz
Refr. charge - tech. limit	1300g / 45,9oz		
Starter	HST / capillary tube or expansion valve		
Motor configuration	CSIR		
Refrigerant	R513A		
Application	MBP		
Approvals	Eco design (EU) 2015/1095, CE, UK CA, VDE		

ambient temperature	[°C / °F]	25 / 77 (suction gas temperature [°C / °F]: 20 / 68, subcooling: 2K)						
evaporating temperature	[°C / °F]	-25 / -13	-20 / -4	-15 / 5	-10 / 14	0 / 32	5 / 41	10 / 50
cooling capacity	[W]	387	502	636	786	1125	1306	1491
COP	[W/W]	1,29	1,46	1,63	1,8	2,09	2,2	2,3
cooling capacity	[Btu/h]	1322	1715	2173	2686	3841	4461	5094
power consumption	[W]	301	344	389	437	539	593	647
current consumption	[A]	2,4	2,5	2,7	2,8	3,2	3,3	3,5

ambient temperature	[°C / °F]	32 / 90 (suction gas temperature [°C / °F]: 20 / 68, subcooling: 2K)						
evaporating temperature	[°C / °F]	-25 / -13	-20 / -4	-15 / 5	-10 / 14	0 / 32	5 / 41	10 / 50
cooling capacity	[W]	340	450	576	714	1020	1182	1347
COP	[W/W]	1,14	1,29	1,43	1,56	1,78	1,88	1,97
cooling capacity	[Btu/h]	1163	1537	1966	2440	3485	4038	4599
power consumption	[W]	297	349	402	458	572	629	685
current consumption	[A]	2,4	2,5	2,7	2,9	3,3	3,5	3,6

ambient temperature	[°C / °F]	38 / 100 (suction gas temperature [°C / °F]: 20 / 68, subcooling: 2K)						
evaporating temperature	[°C / °F]	-25 / -13	-20 / -4	-15 / 5	-10 / 14	0 / 32	5 / 41	
cooling capacity	[W]	309	412	528	654	928	1072	
COP	[W/W]	1,02	1,15	1,27	1,38	1,57	1,65	
cooling capacity	[Btu/h]	1056	1407	1802	2233	3170	3661	
power consumption	[W]	303	358	416	474	591	648	
current consumption	[A]	2,4	2,6	2,8	2,9	3,3	3,5	

ambient temperature	[°C / °F]	43 / 109 (suction gas temperature [°C / °F]: 20 / 68, subcooling: 2K)			
evaporating temperature	[°C / °F]	-25 / -13	-20 / -4	-15 / 5	-10 / 14
cooling capacity	[W]	280	376	482	597
COP	[W/W]	0,91	1,03	1,14	1,24
cooling capacity	[Btu/h]	957	1284	1647	2039
power consumption	[W]	309	366	424	482
current consumption	[A]	2,4	2,6	2,8	3