

Model

Designation **CU SC21CL MG_Z 230/1/50 VAL**



Sales code: 314L4007
Engineering code: CUSC21CL000VE

Application Data

Power supply	220-240V / 50Hz 1~
Refrigerants	R404A-R452A
Refr. charge - tech. limit	1300g / 45,9oz
Starter	HST / capillary tube or expansion valve
Sound pressure (10m)	39,2dB(A)

Configuration data

	Conf. 1	Conf. 2
Voltage range	198 - 254V / 50Hz	198 - 254V / 50Hz
Refrigerant	R404A	R452A
Application	LBP	LBP

Rated performance	<u>pe=-25°C, Tsuc=20°C, Tamb=25°C, subccoling: 2K</u>	
Cooling capacity	944W / 3225Btu/h	887W / 3031Btu/h
Power consumption	689,7W	642,2W
Current consumption	3,7A	3,5A
COP/EER	1,37 / 4,68Btu/Wh	1,38 / 4,72Btu/Wh

Approvals	Eco design (EU) 2015/1095, CE, UK CA, VDE	Eco design (EU) 2015/1095, CE, UK CA, VDE
-----------	----------------------------------------------	----------------------------------------------

Compressor

Designation	SC21CL
Motor configuration	CSCR
Locked rotor amperage	23,4A
Rated load amperage	4,3A
Winding resistance main	3,4Ω
Winding resistance aux	14,4Ω
Oil quantity	550cm ³ / 18,6fl.oz
Oil type	POE
Horsepower rating	5/6 HP

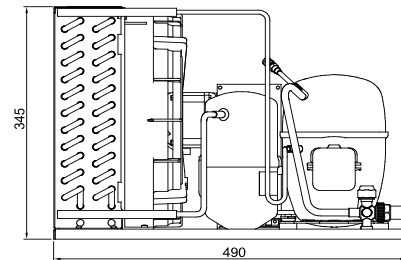

Dimensions

Condensing unit

Height x Width x Depth	345 x 390 x 490 [mm] / 13,6 x 15,4 x 19,3 [in]
Weight	24,3kg / 53,7lbs
Suction adapter	FLARE 3/8"
Discharge adapter	FLARE 1/4"
Process connector	ø6,2mm / 0,24in

Package data

Height x Width x Depth	400 x 500 x 600 [mm] / 15,7 x 19,7 x 23,6 [in]
Weight	28,3kg / 62,5lbs

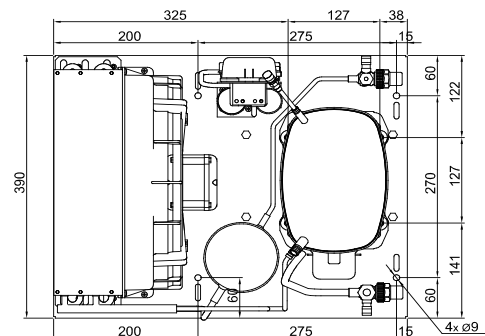

Model

Designation **CU SC21CL MG_Z 230/1/50 VAL**

Sales code: 314L4007
Engineering code: CUSC21CL000VE

Components Condensing-Unit / Spare Parts

Component	Type	Spare part code number
Compressor code	SC21CL	104L2322
Condenser	Condenser (4 rows x 13 tubes)	1340315F70
Fan motor	16W	NET3T16PVN018
Blade code	ø300mm 19°	A300-19
Air flow	769,8m³/h	
Receiver code	Receiver 1,3 liter	100/200VS00
Suction valve code	FLARE 3/8"	FLARE 3/8"
Liquid valve code	FLARE 1/4"	FLARE 1/4"

Compressor starting equipment	Spare part code number
pos. a3 - SC starter kit (550mm)	117-7027
pos. b - plastic cover	103N2009
pos. d - cord relief	103N1004

Wiring Sketch Compressor

Wiring Sketch Condensing Unit

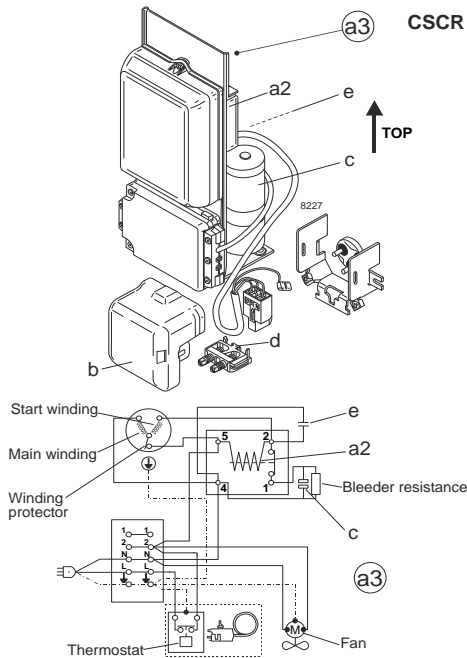

Model

Designation **CU SC21CL MG_Z 230/1/50 VAL**

Sales code: 314L4007

Engineering code: CUSC21CL000VE

Cooling performance - Conf. 1

Power supply	220-240V / 50Hz 1~	Voltage range	198 - 254V / 50Hz
Refr. charge - tech. limit	1300g / 45,9oz		
Starter	HST / capillary tube or expansion valve		
Motor configuration	CSCR		
Refrigerant	R404A		
Application	LBP		
Approvals	Eco design (EU) 2015/1095, CE, UK CA, VDE		

ambient temperature	[°C / °F]	25 / 77 (suction gas temperature [°C / °F]: 20 / 68, subcooling: 2K)						
evaporating temperature	[°C / °F]	-45 / -49	-40 / -40	-35 / -31	-30 / -22	-25 / -13	-20 / -4	-10 / 14
cooling capacity	[W]	320	455	606	769	944	1130	1531
COP	[W/W]	0,75	0,97	1,15	1,28	1,37	1,43	1,52
cooling capacity	[Btu/h]	1092	1554	2068	2626	3225	3858	5230
power consumption	[W]	424	469	528	602	690	788	1010
current consumption	[A]	2,6	2,8	3	3,4	3,7	4,1	5,1

ambient temperature	[°C / °F]	32 / 90 (suction gas temperature [°C / °F]: 20 / 68, subcooling: 2K)						
evaporating temperature	[°C / °F]	-45 / -49	-40 / -40	-35 / -31	-30 / -22	-25 / -13	-20 / -4	-10 / 14
cooling capacity	[W]	278	386	510	650	803	969	1342
COP	[W/W]	0,67	0,82	0,95	1,05	1,12	1,18	1,29
cooling capacity	[Btu/h]	950	1318	1743	2218	2742	3309	4582
power consumption	[W]	413	469	539	622	716	819	1042
current consumption	[A]	2,6	2,8	3	3,4	3,8	4,3	5,3

ambient temperature	[°C / °F]	38 / 100 (suction gas temperature [°C / °F]: 20 / 68, subcooling: 2K)						
evaporating temperature	[°C / °F]	-45 / -49	-40 / -40	-35 / -31	-30 / -22	-25 / -13	-20 / -4	
cooling capacity	[W]	233	321	426	549	688	842	
COP	[W/W]	0,56	0,67	0,77	0,86	0,93	1	
cooling capacity	[Btu/h]	795	1095	1456	1874	2348	2874	
power consumption	[W]	414	477	553	641	738	842	
current consumption	[A]	2,5	2,7	3	3,4	3,9	4,4	

ambient temperature	[°C / °F]	43 / 109 (suction gas temperature [°C / °F]: 20 / 68, subcooling: 2K)						
evaporating temperature	[°C / °F]	-45 / -49	-40 / -40	-35 / -31	-30 / -22	-25 / -13		
cooling capacity	[W]	198	271	363	474	603		
COP	[W/W]	0,47	0,56	0,64	0,73	0,8		
cooling capacity	[Btu/h]	675	925	1241	1620	2059		
power consumption	[W]	418	485	564	653	750		
current consumption	[A]	2,4	2,7	3	3,4	3,9		

Model

Designation **CU SC21CL MG_Z 230/1/50 VAL**

Sales code: 314L4007

Engineering code: CUSC21CL000VE

Cooling performance - Conf. 2

Power supply	220-240V / 50Hz 1~	Voltage range	198 - 254V / 50Hz
Refr. charge - tech. limit	1300g / 45,9oz		
Starter	HST / capillary tube or expansion valve		
Motor configuration	CSCR		
Refrigerant	R452A		
Application	LBP		
Approvals	Eco design (EU) 2015/1095, CE, UK CA, VDE		

ambient temperature	[°C / °F]	25 / 77 (suction gas temperature [°C / °F]: 20 / 68, subcooling: 2K)						
evaporating temperature	[°C / °F]	-45 / -49	-40 / -40	-35 / -31	-30 / -22	-25 / -13	-20 / -4	-10 / 14
cooling capacity	[W]	280	410	556	715	887	1071	1474
COP	[W/W]	0,72	0,95	1,14	1,28	1,38	1,45	1,55
cooling capacity	[Btu/h]	958	1401	1898	2442	3031	3658	5035
power consumption	[W]	391	433	489	559	642	737	952
current consumption	[A]	2,3	2,5	2,8	3,1	3,5	3,9	4,9

ambient temperature	[°C / °F]	32 / 90 (suction gas temperature [°C / °F]: 20 / 68, subcooling: 2K)						
evaporating temperature	[°C / °F]	-45 / -49	-40 / -40	-35 / -31	-30 / -22	-25 / -13	-20 / -4	-10 / 14
cooling capacity	[W]	245	349	469	605	756	921	1295
COP	[W/W]	0,65	0,81	0,95	1,05	1,14	1,2	1,32
cooling capacity	[Btu/h]	836	1190	1602	2066	2582	3146	4423
power consumption	[W]	376	429	495	575	665	765	984
current consumption	[A]	2,3	2,5	2,8	3,2	3,6	4	5

ambient temperature	[°C / °F]	38 / 100 (suction gas temperature [°C / °F]: 20 / 68, subcooling: 2K)						
evaporating temperature	[°C / °F]	-45 / -49	-40 / -40	-35 / -31	-30 / -22	-25 / -13	-20 / -4	
cooling capacity	[W]	204	289	392	512	648	801	
COP	[W/W]	0,55	0,67	0,77	0,87	0,95	1,02	
cooling capacity	[Btu/h]	697	987	1338	1747	2212	2735	
power consumption	[W]	373	433	506	590	684	786	
current consumption	[A]	2,2	2,5	2,8	3,2	3,6	4,1	

ambient temperature	[°C / °F]	43 / 109 (suction gas temperature [°C / °F]: 20 / 68, subcooling: 2K)				
evaporating temperature	[°C / °F]	-45 / -49	-40 / -40	-35 / -31	-30 / -22	-25 / -13
cooling capacity	[W]	172	243	333	441	568
COP	[W/W]	0,46	0,56	0,65	0,73	0,82
cooling capacity	[Btu/h]	588	830	1137	1506	1939
power consumption	[W]	372	437	514	601	695
current consumption	[A]	2,2	2,5	2,9	3,3	3,7