

Model

Designation **CU TL4CL MG_Z 230/1/50 VAL**



Sales code: 314L2001
Engineering code: CUTL4CL0000VE

Application Data

Power supply 220-240V / 50Hz 1~
Refrigerants R404A-R452A
Refr. charge - tech. limit 600g / 21,2oz
Starter HST / capillary tube or expansion valve
Sound pressure (10m) 23dB(A)

Configuration data

	Conf. 1	Conf. 2
Voltage range	198 - 254V / 50Hz	198 - 254V / 50Hz
Refrigerant	R404A	R452A
Application	LBP	LBP

Rated performance pe=-25°C, Tsuc=20°C, Tamb=25°C, subcooling: 2K

Cooling capacity	184W / 627Btu/h	171W / 582Btu/h
Power consumption	137,8W	129,4W
Current consumption	1,1A	1A
COP/EER	1,33 / 4,55Btu/Wh	1,32 / 4,5Btu/Wh

Approvals Eco design (EU) 2015/1095, CE, UK CA, VDE Eco design (EU) 2015/1095, CE, UK CA, VDE

Compressor

Designation **TL4CL**
Motor configuration CSIR
Locked rotor amperage 5,7A
Rated load amperage 1,1A
Winding resistance main 14,5Ω
Winding resistance aux 14,8Ω
Oil quantity 280cm³ / 9,5fl.oz
Oil type POE
Horsepower rating 1/7 HP

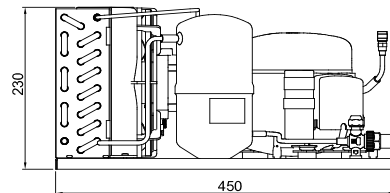

Dimensions

Condensing unit

Height x Width x Depth 230 x 350 x 450 [mm] / 9,1 x 13,8 x 17,7 [in]
Weight 13,3kg / 29,3lbs
Suction adapter FLARE 1/4"
Discharge adapter FLARE 1/4"
Process connector ø6,2mm / 0,24in

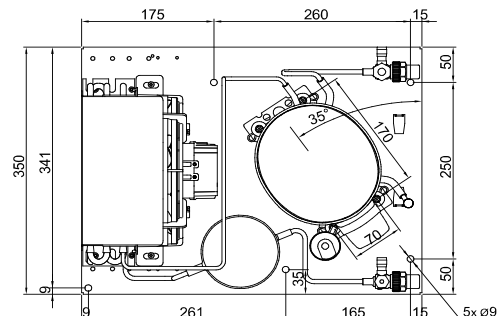

Package data

Height x Width x Depth 300 x 450 x 550 [mm] / 11,8 x 17,7 x 21,7 [in]
Weight 16,3kg / 35,9lbs

Model

Designation **CU TL4CL MG_Z 230/1/50 VAL**

Sales code: 314L2001
Engineering code: CUTL4CL0000VE

Components Condensing-Unit / Spare Parts

Component	Type	Spare part code number
Compressor code	TL4CL	102U2071
Condenser	Condenser (3 rows x 8 tubes)	0830210A70
Fan motor		62010145
Blade code	ø200mm 28°	A200-28
Air flow	262,4m³/h	
Receiver code	Receiver 1,3 liter	100/200VS00
Suction valve code	FLARE 1/4"	FLARE 1/4"
Liquid valve code	FLARE 1/4"	FLARE 1/4"

Compressor starting equipment	Spare part code number
pos. a2 - relay	117U6000
pos. c - start capacitor (60µF)	117U5014
pos. d - cord relief	103N1010
pos. b - plastic cover	103N2010

Wiring Sketch Compressor

Wiring Sketch Condensing Unit

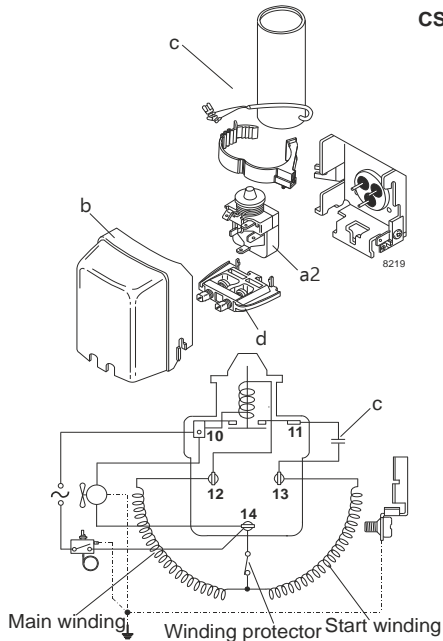

Model

Designation	CU TL4CL MG_Z 230/1/50 VAL	Sales code:	314L2001
		Engineering code:	CUTL4CL0000VE

Cooling performance - Conf. 1

Power supply	220-240V / 50Hz 1~	Voltage range	198 - 254V / 50Hz
Refr. charge - tech. limit	600g / 21,2oz		
Starter	HST / capillary tube or expansion valve		
Motor configuration	CSIR		
Refrigerant	R404A		
Application	LBP		
Approvals	Eco design (EU) 2015/1095, CE, UK CA, VDE		

ambient temperature	[°C / °F]	25 / 77							(suction gas temperature [°C / °F]: 20 / 68, subcooling: 2K)
evaporating temperature	[°C / °F]	-45 / -49	-40 / -40	-35 / -31	-25 / -13	-20 / -4	-10 / 14	-5 / 23	
cooling capacity	[W]	58	84	113	184	225	323	379	
COP	[W/W]	0,64	0,87	1,05	1,33	1,45	1,69	1,82	
cooling capacity	[Btu/h]	200	286	386	627	769	1102	1295	
power consumption	[W]	90	97	108	138	155	191	208	
current consumption	[A]	0,8	0,9	0,9	1,1	1,2	1,4	1,5	

ambient temperature	[°C / °F]	32 / 90							(suction gas temperature [°C / °F]: 20 / 68, subcooling: 2K)
evaporating temperature	[°C / °F]	-45 / -49	-40 / -40	-35 / -31	-25 / -13	-20 / -4	-10 / 14	-5 / 23	
cooling capacity	[W]	61	79	102	160	196	284	336	
COP	[W/W]	0,69	0,81	0,93	1,13	1,21	1,41	1,52	
cooling capacity	[Btu/h]	208	271	348	547	670	969	1147	
power consumption	[W]	89	97	110	142	162	202	221	
current consumption	[A]	0,8	0,9	0,9	1,1	1,2	1,4	1,5	

ambient temperature	[°C / °F]	38 / 100							(suction gas temperature [°C / °F]: 20 / 68, subcooling: 2K)
evaporating temperature	[°C / °F]	-45 / -49	-40 / -40	-35 / -31	-25 / -13	-20 / -4	-10 / 14	-5 / 23	
cooling capacity	[W]	55	69	87	137	169	250	300	
COP	[W/W]	0,63	0,71	0,79	0,94	1,02	1,2	1,3	
cooling capacity	[Btu/h]	188	235	297	467	578	855	1024	
power consumption	[W]	88	97	110	145	166	209	231	
current consumption	[A]	0,8	0,9	0,9	1,1	1,2	1,4	1,6	

ambient temperature	[°C / °F]	43 / 109							(suction gas temperature [°C / °F]: 20 / 68, subcooling: 2K)
evaporating temperature	[°C / °F]	-45 / -49	-40 / -40	-35 / -31	-25 / -13	-20 / -4	-10 / 14		
cooling capacity	[W]	47	58	73	117	147	225		
COP	[W/W]	0,55	0,61	0,67	0,8	0,88	1,05		
cooling capacity	[Btu/h]	162	198	249	401	503	768		
power consumption	[W]	85	95	109	146	168	214		
current consumption	[A]	0,8	0,9	0,9	1,1	1,2	1,5		

Model

Designation	CU TL4CL MG_Z 230/1/50 VAL	Sales code:	314L2001
		Engineering code:	CUTL4CL0000VE

Cooling performance - Conf. 2

Power supply	220-240V / 50Hz 1~	Voltage range	198 - 254V / 50Hz
Refr. charge - tech. limit	600g / 21,2oz		
Starter	HST / capillary tube or expansion valve		
Motor configuration	CSIR		
Refrigerant	R452A		
Application	LBP		
Approvals	Eco design (EU) 2015/1095, CE, UK CA, VDE		

ambient temperature	[°C / °F]	25 / 77							(suction gas temperature [°C / °F]: 20 / 68, subcooling: 2K)
evaporating temperature	[°C / °F]	-45 / -49	-40 / -40	-35 / -31	-25 / -13	-20 / -4	-10 / 14	-5 / 23	
cooling capacity	[W]	50	74	102	171	211	307	362	
COP	[W/W]	0,6	0,82	1,01	1,33	1,45	1,7	1,83	
cooling capacity	[Btu/h]	170	253	349	582	721	1048	1238	
power consumption	[W]	83	90	101	129	146	181	198	
current consumption	[A]	0,8	0,8	0,9	1	1,1	1,3	1,4	

ambient temperature	[°C / °F]	32 / 90							(suction gas temperature [°C / °F]: 20 / 68, subcooling: 2K)
evaporating temperature	[°C / °F]	-45 / -49	-40 / -40	-35 / -31	-25 / -13	-20 / -4	-10 / 14	-5 / 23	
cooling capacity	[W]	53	71	93	149	184	271	322	
COP	[W/W]	0,65	0,79	0,91	1,12	1,21	1,42	1,53	
cooling capacity	[Btu/h]	181	242	317	510	630	924	1101	
power consumption	[W]	82	90	102	133	152	191	210	
current consumption	[A]	0,8	0,8	0,9	1,1	1,1	1,4	1,5	

ambient temperature	[°C / °F]	38 / 100							(suction gas temperature [°C / °F]: 20 / 68, subcooling: 2K)
evaporating temperature	[°C / °F]	-45 / -49	-40 / -40	-35 / -31	-25 / -13	-20 / -4	-10 / 14	-5 / 23	
cooling capacity	[W]	48	61	79	128	159	240	289	
COP	[W/W]	0,6	0,69	0,77	0,94	1,02	1,21	1,31	
cooling capacity	[Btu/h]	164	210	270	436	544	818	987	
power consumption	[W]	80	89	102	136	156	198	220	
current consumption	[A]	0,8	0,8	0,9	1,1	1,2	1,4	1,5	

ambient temperature	[°C / °F]	43 / 109							(suction gas temperature [°C / °F]: 20 / 68, subcooling: 2K)
evaporating temperature	[°C / °F]	-45 / -49	-40 / -40	-35 / -31	-25 / -13	-20 / -4	-10 / 14		
cooling capacity	[W]	41	52	66	110	139	215		
COP	[W/W]	0,53	0,6	0,65	0,8	0,88	1,06		
cooling capacity	[Btu/h]	141	177	226	374	475	736		
power consumption	[W]	78	87	101	137	158	203		
current consumption	[A]	0,8	0,8	0,9	1,1	1,2	1,4		