

Model

Designation **CU TL5G MG_Y 230/1/50 VAL**



Sales code: 314G2001
Engineering code: CUTL5G00000VE

Application Data

Power supply 220-240V / 50Hz 1~
Refrigerants R134a-R513A
Refr. charge - tech. limit 400g / 14,1oz
Starter HST / capillary tube or expansion valve
Sound pressure (10m) 22,5dB(A)

Configuration data

	Conf. 1	Conf. 2
Voltage range	187 - 254V / 50Hz	187 - 254V / 50Hz
Refrigerant	R134a	R513A
Application	LBP+MBP+HBP	LBP+MBP+HBP
Rated performance	<u>pe=-10°C, Tsuc=20°C, Tamb=25°C, subcooling: 2K</u>	
Cooling capacity	239W / 815Btu/h	252W / 859Btu/h
Power consumption	136,5W	144,3W
Current consumption	1,1A	1,1A
COP/EER	1,75 / 5,97Btu/Wh	1,74 / 5,95Btu/Wh
Approvals	Eco design (EU) 2015/1095, CE, UK CA, VDE	Eco design (EU) 2015/1095, CE, UK CA, VDE

Compressor

Designation **TL5G**
Motor configuration CSIR
Locked rotor amperage 5,7A
Rated load amperage 1,1A
Winding resistance main 14,5Ω
Winding resistance aux 14,8Ω
Oil quantity 280cm³ / 9,5fl.oz
Oil type POE
Horsepower rating 1/10 HP

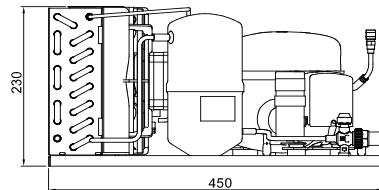

Dimensions

Condensing unit

Height x Width x Depth 230 x 350 x 450 [mm] / 9,1 x 13,8 x 17,7 [in]
Weight 14,1kg / 31,1lbs
Suction adapter FLARE 1/4"
Discharge adapter FLARE 1/4"
Process connector ø6,2mm / 0,24in

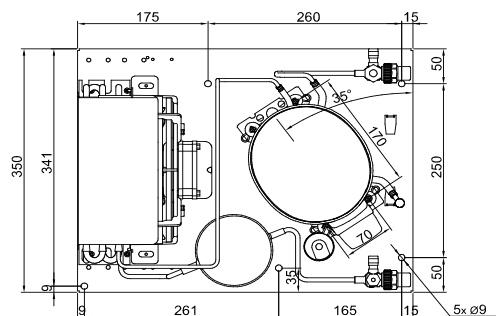

Package data

Height x Width x Depth 300 x 450 x 550 [mm] / 11,8 x 17,7 x 21,7 [in]
Weight 17,1kg / 37,8lbs

Model

Designation **CU TL5G MG_Y 230/1/50 VAL**

Sales code: 314G2001
Engineering code: CUTL5G00000VE

Components Condensing-Unit / Spare Parts

Component	Type	Spare part code number
Compressor code	TL5G	102G4550
Condenser	Condenser (3 rows x 8 tubes)	0830210A70
Fan motor	5W	AA600709X
Blade code	ø200mm 28°	A200-28
Air flow	256,1m³/h	
Receiver code	Receiver 1,3 liter	100/200VS00
Suction valve code	FLARE 1/4"	FLARE 1/4"
Liquid valve code	FLARE 1/4"	FLARE 1/4"

Compressor starting equipment	Spare part code number
pos. a2 - relay	117U6000
pos. c - start capacitor (60µF)	117U5014
pos. d - cord relief	103N1010
pos. b - plastic cover	103N2010

Wiring Sketch Compressor

Wiring Sketch Condensing Unit

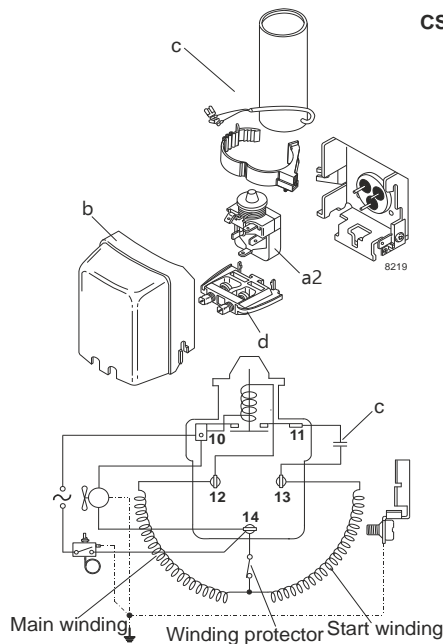

Model

Designation **CU TL5G MG_Y 230/1/50 VAL**

Sales code: 314G2001

Engineering code: CUTL5G00000VE

Cooling performance - Conf. 1

Power supply	220-240V / 50Hz 1~	Voltage range	187 - 254V / 50Hz
Refr. charge - tech. limit	400g / 14,1oz		
Starter	HST / capillary tube or expansion valve		
Motor configuration	CSIR		
Refrigerant	R134a		
Application	LBP+MBP+HBP		
Approvals	Eco design (EU) 2015/1095, CE, UK CA, VDE		

ambient temperature	[°C / °F]	25 / 77 (suction gas temperature [°C / °F]: 20 / 68, subcooling: 2K)						
evaporating temperature	[°C / °F]	-30 / -22	-25 / -13	-20 / -4	-10 / 14	0 / 32	5 / 41	15 / 59
cooling capacity	[W]	92	119	153	239	351	418	568
COP	[W/W]	1,05	1,2	1,38	1,76	2,1	2,27	2,54
cooling capacity	[Btu/h]	314	407	521	815	1200	1426	1938
power consumption	[W]	88	99	111	136	167	184	224
current consumption	[A]	1	1	1	1,1	1,1	1,2	1,4

ambient temperature	[°C / °F]	32 / 90 (suction gas temperature [°C / °F]: 20 / 68, subcooling: 2K)						
evaporating temperature	[°C / °F]	-30 / -22	-25 / -13	-20 / -4	-10 / 14	0 / 32	5 / 41	15 / 59
cooling capacity	[W]	82	107	138	218	321	382	520
COP	[W/W]	0,92	1,06	1,21	1,54	1,83	1,97	2,18
cooling capacity	[Btu/h]	279	366	472	743	1098	1305	1777
power consumption	[W]	89	101	114	142	175	194	238
current consumption	[A]	1	1	1	1,1	1,2	1,2	1,4

ambient temperature	[°C / °F]	38 / 100 (suction gas temperature [°C / °F]: 20 / 68, subcooling: 2K)						
evaporating temperature	[°C / °F]	-30 / -22	-25 / -13	-20 / -4	-10 / 14	0 / 32	5 / 41	15 / 59
cooling capacity	[W]	73	97	126	200	296	352	480
COP	[W/W]	0,81	0,94	1,09	1,36	1,62	1,73	1,92
cooling capacity	[Btu/h]	249	332	431	684	1011	1204	1640
power consumption	[W]	90	103	116	147	183	203	250
current consumption	[A]	1	1	1	1,1	1,2	1,3	1,5

ambient temperature	[°C / °F]	43 / 109 (suction gas temperature [°C / °F]: 20 / 68, subcooling: 2K)						
evaporating temperature	[°C / °F]	-30 / -22	-25 / -13	-20 / -4	-10 / 14	0 / 32	5 / 41	15 / 59
cooling capacity	[W]	66	89	117	186	275	328	447
COP	[W/W]	0,73	0,86	0,99	1,23	1,46	1,55	1,71
cooling capacity	[Btu/h]	225	304	398	635	941	1120	1527
power consumption	[W]	90	104	118	151	189	211	261
current consumption	[A]	1	1	1	1,1	1,2	1,3	1,5

Model

Designation **CU TL5G MG_Y 230/1/50 VAL**

Sales code: 314G2001

Engineering code: CUTL5G00000VE

Cooling performance - Conf. 2

Power supply	220-240V / 50Hz 1~	Voltage range	187 - 254V / 50Hz
Refr. charge - tech. limit	400g / 14,1oz		
Starter	HST / capillary tube or expansion valve		
Motor configuration	CSIR		
Refrigerant	R513A		
Application	LBP+MBP+HBP		
Approvals	Eco design (EU) 2015/1095, CE, UK CA, VDE		

ambient temperature	[°C / °F]	25 / 77 (suction gas temperature [°C / °F]: 20 / 68, subcooling: 2K)						
evaporating temperature	[°C / °F]	-30 / -22	-25 / -13	-20 / -4	-10 / 14	0 / 32	5 / 41	15 / 59
cooling capacity	[W]	102	130	164	252	364	429	575
COP	[W/W]	1,06	1,23	1,39	1,75	2,08	2,22	2,47
cooling capacity	[Btu/h]	347	444	561	859	1243	1465	1964
power consumption	[W]	96	106	118	144	175	193	233
current consumption	[A]	1	1	1	1,1	1,2	1,2	1,4

ambient temperature	[°C / °F]	32 / 90 (suction gas temperature [°C / °F]: 20 / 68, subcooling: 2K)						
evaporating temperature	[°C / °F]	-30 / -22	-25 / -13	-20 / -4	-10 / 14	0 / 32	5 / 41	15 / 59
cooling capacity	[W]	90	116	148	228	331	390	523
COP	[W/W]	0,93	1,06	1,21	1,52	1,8	1,92	2,12
cooling capacity	[Btu/h]	307	398	506	779	1129	1331	1785
power consumption	[W]	97	109	122	150	184	203	247
current consumption	[A]	1	1	1	1,1	1,2	1,3	1,4

ambient temperature	[°C / °F]	38 / 100 (suction gas temperature [°C / °F]: 20 / 68, subcooling: 2K)						
evaporating temperature	[°C / °F]	-30 / -22	-25 / -13	-20 / -4	-10 / 14	0 / 32	5 / 41	15 / 59
cooling capacity	[W]	80	105	135	208	302	357	478
COP	[W/W]	0,82	0,95	1,09	1,33	1,57	1,68	1,84
cooling capacity	[Btu/h]	274	359	460	712	1033	1218	1633
power consumption	[W]	97	110	124	156	192	213	260
current consumption	[A]	1	1	1	1,1	1,2	1,3	1,5

ambient temperature	[°C / °F]	43 / 109 (suction gas temperature [°C / °F]: 20 / 68, subcooling: 2K)						
evaporating temperature	[°C / °F]	-30 / -22	-25 / -13	-20 / -4	-10 / 14	0 / 32	5 / 41	15 / 59
cooling capacity	[W]	72	96	124	192	279	329	441
COP	[W/W]	0,73	0,86	0,98	1,2	1,4	1,49	1,63
cooling capacity	[Btu/h]	247	328	423	657	953	1124	1506
power consumption	[W]	98	112	127	160	199	221	271
current consumption	[A]	1	1	1,1	1,2	1,3	1,3	1,5