

**Model**

Designation	<b>DLE4CN</b>	<b>115-127V/60Hz 1~</b>	Sales code:	<b>102H3482</b>
-------------	---------------	-------------------------	-------------	-----------------

**Compressor design**

Oil type	Polyolester	Refrigerant(s)	<b>R290</b>
Oil viscosity	32cSt	Displacement	4cm <sup>3</sup> / 0,24cu.in
Oil quantity	221cm <sup>3</sup> / 7,5fl.oz	Compressors on pallet	100
Refr. charge - tech. limit	150g / 5,3oz		
Free gas volume comp.	1465cm <sup>3</sup> / 49,5fl.oz		
Weight	8kg / 17,6lbs		
Motor protection	1# internal		
Winding resistance main	3,61Ω (at 25°C)		
Winding resistance aux	5,93Ω (at 25°C)		
Max. winding temp.	125°C / 257°F		
Max. discharge temp.	120°C / 248°F		



**General - Configurations with DLE4CN**

	<b>Conf. 1</b>	<b>Conf. 2</b>	<b>Conf. 3</b>
Motorconfiguration	CSIR	RSIR	RSCR
Power supply (nominal)	115V/60Hz	115V/60Hz	115V/60Hz
Number of phases	1	1	1
Voltage range	95-135V	95-135V	95-135V
Approvals	UL, CCC	UL, CCC	UL, CCC
Starting torque	HST	LST	LST
Note	- / -		

**Applications with DLE4CN**

	<b>Conf. 1</b>	<b>Conf. 2</b>	<b>Conf. 3</b>
Refrigerant	R290	R290	R290
Application	LBP+MBP	LBP+MBP	LBP+MBP
System cooling	static	static	static
Hot gas defrost	OK	OK	OK
Long interval pull down	OK	OK	OK

**Electrical data - Configurations with DLE4CN**

	<b>Conf. 1</b>	<b>Conf. 2</b>	<b>Conf. 3</b>
Starting device type	relay	PTC	PTC
Run capacitor	-/-	-/-	15μF
Start capacitor	240μF	-/-	-/-
LRA (locked rotor amps / 4s)	16,6A	12,7A	12,7A
RLA (rated load amps / 1s)	2,53A	2,53A	2,4A
Cut in current	16,6A	20,9A	20,9A
IP class	21	21	21

**Model**

Designation	<b>DLE4CN</b>	115-127V/60Hz 1~	Sales code:	<b>102H3482</b>
-------------	---------------	------------------	-------------	-----------------

**Compressor dimensions**

<b>Housing</b>	A Height	174mm / 6,85in
	B Height	168mm / 6,61in
	C Length shell	183mm / 7,2in
	D Length w. cover	232mm / 9,13in
	E Width	156mm / 6,14in

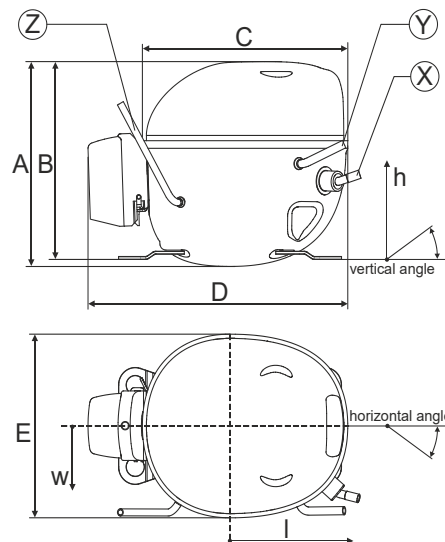

<b>Connectors</b>		<b>Suction</b>	<b>Discharge</b>	<b>Process</b>
		<b>X</b>	<b>Y</b>	<b>Z</b>
Diameter	[mm]	øi 8,11-8,29	øi 6,41-6,59	øi 6,4-6,6
(i:inside, o:outside)	[in]	øi 0,32-0,33	øi 0,25-0,26	øi 0,25-0,26
Material		copper	copper	copper
Horizontal angle	±2°	10°	0°	0°
Vertical angle	±2°	18°	25°	119°
Position l/h/w	[mm]	135/77/67	98/96/72	-98/133/73
	[in]	5,3/3/2,6	3,8/3,8/2,8	-3,9/5,2/2,9
Straight tube l.	[mm]	12	12	12
	[in]	0,5	0,5	0,5

**Compressor fixation**

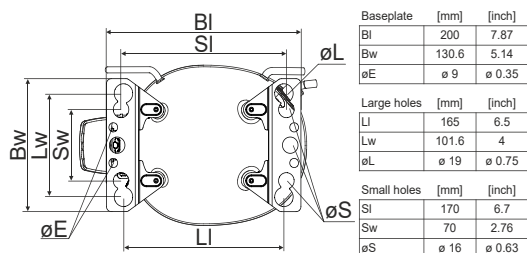

**Bolt joint**

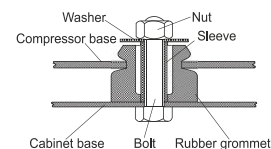

**Snap-on**

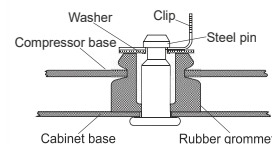

<b>Mounting accessories</b>	one comp.	multi pack
Bolt joint   M6   ø16mm	118-1917	118-1918
Bolt joint   ø1/4"   ø16mm	118-1946	
Bolt joint   ø1/4"   ø19mm	118-1949	
Snap-on   ø7,3   ø16mm	118-1947	118-1919

**Model**

Designation	<b>DLE4CN</b>	<b>115V/60Hz</b>	<b>Conf. 1</b>	Sales code:	<b>102H3482</b>
-------------	---------------	------------------	----------------	-------------	-----------------

**Configuration**

Motorconfiguration	CSIR	
Power supply (nominal)	115V/60Hz 1~	
Refrigerant	R290	
Application	LBP+MBP	
Voltage range	95-135V	
Starting torque	HST	
Approvals	UL	SA3693
	CCC	

**Electrical accessories / wiring diagram**

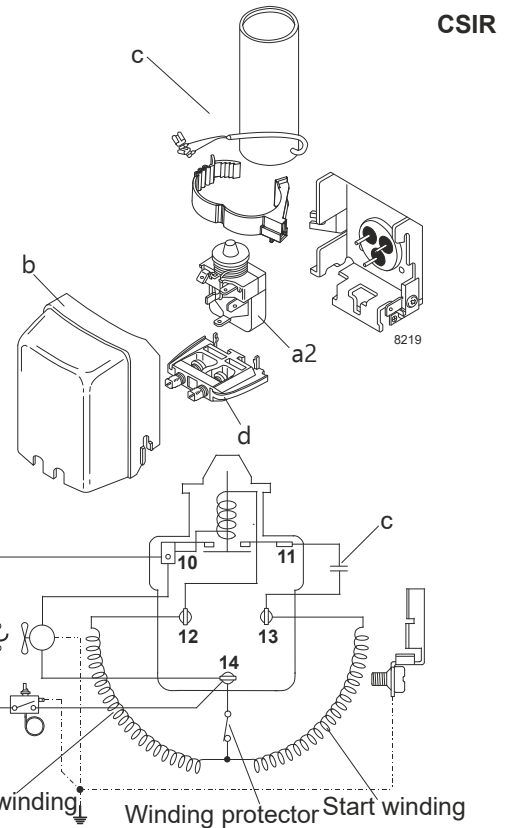

**Ambient temperatures / system cooling**

Ambient temperature min.:	10°C / 50°F
Ambient temperature max.:	43°C / 110°F

System cooling (n/a: outside limits)			
T ambient	LBP	MBP	HBP
32°C / 90°F	static	static	n/a
38°C / 100°F	static	static	n/a
43°C / 110°F	fan 3m/s	fan 3m/s	n/a

**Operation pressure range**

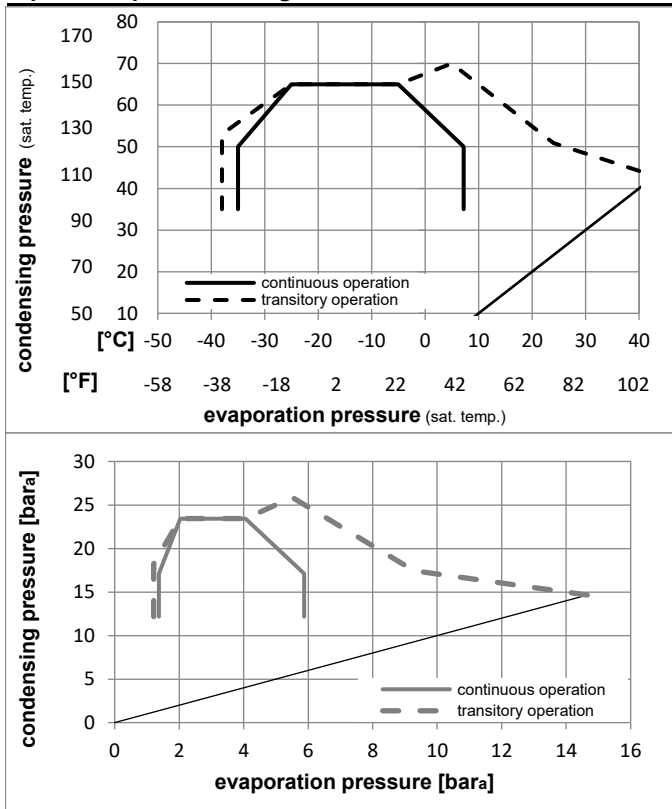

**Components**

a2	relay	117U7022
c	start capacitor (240µF)	117U5023
b	plastic cover	103N0492
d	cord relief	103N1010

**Model**

Designation **DLE4CN 115V/60Hz** Conf. 1 Sales code: **102H3482**

**Optimization + standard conditions**

115V/60Hz 1~, CSIR, fan 3m/s, UL, CCC

	Evaporating pressure (saturation temperature)				Condensing pressure (saturation temperature)						Power consumption			ASHRAE LBP
	pe	pc	RGT	Tliq	Cooling capacity			COP	EER	P1	I	Ref. mass flow		
	[°C]	[°C]	[°C]	[°C]	[W]	[Btu/h]	[kcal/h]	[W/W]	[Btu/Wh]	[kcal/Wh]	[W]	[A]	[kg/h]	
	-23,3	54,4	32,2	32,2	229,3	783	197,3	1,50	5,11	1,29	153,2	1,88	2,32	ASHRAE LBP
	[-10]	130	90	90										
	-25	55	32	55	171,7	586	147,8	1,16	3,95	1,00	148,3	1,85	2,14	cecomaf LBP
	[-13]	131	89,6	131										
	-35	40	20	40	132,0	451	113,6	1,16	3,96	1,00	113,9	1,71	1,51	EN12900 LBP
	[-31]	104	68	104										
	-6,66	54,4	35	46,1	414,5	1416	356,7	2,03	6,94	1,75	203,9	2,28	4,73	ASHRAE MBP
	[20]	130	95	115										
	-10	55	32	55	328,0	1120	282,3	1,68	5,74	1,45	195,2	2,20	4,15	cecomaf MBP
	[14]	131	89,6	131										
	-10	45	20	45	369,0	1260	317,5	2,06	7,05	1,78	178,8	2,11	4,53	EN12900 MBP
	[14]	113	68	113										

**Performance tables**

115V/60Hz 1~, CSIR, fan 3m/s, UL, CCC

	pe	Cooling capacity			COP	EER	P1	I	m		
	[°C]	[°F]	[W]	[Btu/h]	[kcal/h]	[W/W]	[Btu/Wh]	[kcal/Wh]	[W]	[A]	[kg/h]
[°C / °F]	-35	-31	125,8	429	108,2	1,09	3,71	0,93	115,8	1,72	1,41
cond. pressure	-23,3	-10	220,9	754	190,1	1,51	5,16	1,30	146,1	1,87	2,49
pc= 45/113	-15	5	315,1	1076	271,1	1,88	6,43	1,62	167,3	2,02	3,58
return gas temp.	-9,4	15	392,4	1340	337,7	2,18	7,45	1,88	180,0	2,12	4,49
RGT= 32/90	-3,9	25	483,0	1650	415,7	2,53	8,64	2,18	190,8	2,19	5,57
liquid temp	0	32	554,9	1895	477,6	2,82	9,62	2,42	197,0	2,23	6,44
Tliq= 45/113	7,2	45	708,7	2420	610,0	3,46	11,83	2,98	204,7	2,25	8,33
[°C / °F]	-35	-31	103,5	353	89,0	0,88	2,99	0,75	118,0	1,72	1,28
cond. pressure	-23,3	-10	185,6	634	159,7	1,21	4,13	1,04	153,6	1,88	2,31
pc= 55/131	-15	5	267,5	913	230,2	1,49	5,08	1,28	180,0	2,08	3,36
return gas temp	-9,4	15	335,3	1145	288,5	1,70	5,82	1,47	196,9	2,22	4,24
RGT= 32/90	-3,9	25	415,2	1418	357,3	1,95	6,67	1,68	212,5	2,35	5,30
liquid temp	0	32	479,0	1636	412,2	2,15	7,35	1,85	222,4	2,44	6,15
Tliq= 55/131	7,2	45	616,3	2105	530,4	2,59	8,86	2,23	237,7	2,56	8,03

**Model**

Designation	<b>DLE4CN</b>	<b>115V/60Hz</b>	<b>Conf. 2</b>	Sales code:	<b>102H3482</b>
-------------	---------------	------------------	----------------	-------------	-----------------

**Configuration**

Motorconfiguration	RSIR
Power supply (nominal)	115V/60Hz 1~
Refrigerant	R290
Application	LBP+MBP
Voltage range	95-135V
Starting torque	LST
Approvals	UL SA3693
	CCC

**Electrical accessories / wiring diagram**

RSIR

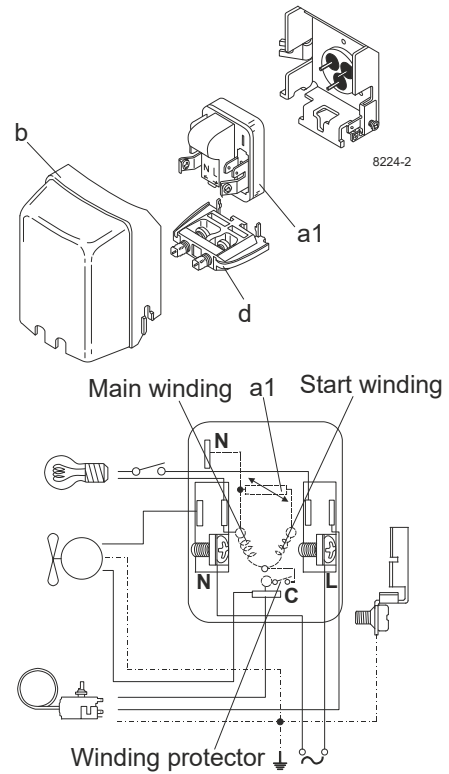

**Ambient temperatures / system cooling**

Ambient temperature min.:	10°C / 50°F
Ambient temperature max.:	43°C / 110°F

System cooling (n/a: outside limits)			
T ambient	LBP	MBP	HBP
32°C / 90°F	static	static	n/a
38°C / 100°F	static	static	n/a
43°C / 110°F	fan 3m/s	fan 3m/s	n/a

**Operation pressure range**

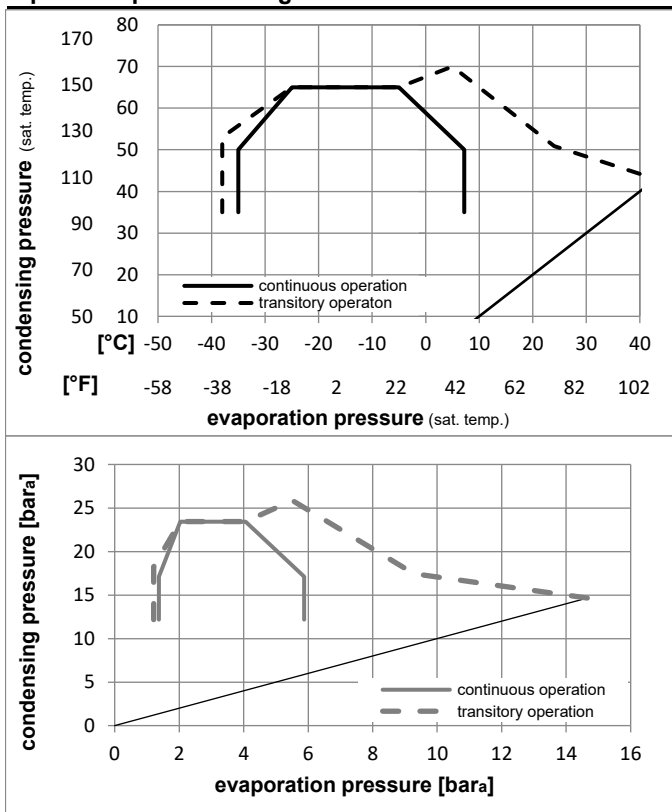

**Components**

a1	e-PTC starter	103N0058
b	plastic cover	103N0492
d	cord relief	103N1010

**Alternative components**

a1	e-PTC starter (115V, 50Ohm, 6.3mm, 4.8-cap)	103N0057
b	plastic cover	103N0492
d	cord relief	103N1010

**Model**

Designation	<b>DLE4CN</b>	<b>115V/60Hz</b>	<b>Conf. 2</b>	Sales code:	<b>102H3482</b>
-------------	---------------	------------------	----------------	-------------	-----------------

**Optimization + standard conditions**

115V/60Hz 1~, RSIR, fan 3m/s, UL, CCC

	Evaporating pressure (saturation temperature)				Condensing pressure (saturation temperature)						Power consumption			ASHRAE LBP
	pe	pc	RGT	Tliq	Cooling capacity			COP	EER	P1	I	Ref. mass flow		
	[°C]	[°F]	[°C]	[°F]	[W]	[Btu/h]	[kcal/h]	[W/W]	[Btu/Wh]	[kcal/Wh]	[W]	[A]	[kg/h]	
	-23,3	54,4	32,2	32,2	229,3	783	197,3	1,50	5,11	1,29	153,2	1,88	2,32	ASHRAE LBP
	-10	130	90	90										
	-25	55	32	55	171,7	586	147,8	1,16	3,95	1,00	148,3	1,85	2,14	cecomaf LBP
	-13	131	89,6	131										
	-35	40	20	40	132,0	451	113,6	1,16	3,96	1,00	113,9	1,71	1,51	EN12900 LBP
	-31	104	68	104										
	-6,66	54,4	35	46,1	414,5	1416	356,7	2,03	6,94	1,75	203,9	2,28	4,73	ASHRAE MBP
	20	130	95	115										
	-10	55	32	55	328,0	1120	282,3	1,68	5,74	1,45	195,2	2,20	4,15	cecomaf MBP
	14	131	89,6	131										
	-10	45	20	45	369,0	1260	317,5	2,06	7,05	1,78	178,8	2,11	4,53	EN12900 MBP
	14	113	68	113										

**Performance tables**

115V/60Hz 1~, RSIR, fan 3m/s, UL, CCC

	pe	Cooling capacity			COP	EER	P1	I	m		
	[°C]	[°F]	[W]	[Btu/h]	[kcal/h]	[W/W]	[Btu/Wh]	[kcal/Wh]	[W]	[A]	[kg/h]
[°C / °F]	-35	-31	125,8	429	108,2	1,09	3,71	0,93	115,8	1,72	1,41
cond. pressure	-23,3	-10	220,9	754	190,1	1,51	5,16	1,30	146,1	1,87	2,49
pc= 45/113	-15	5	315,1	1076	271,1	1,88	6,43	1,62	167,3	2,02	3,58
return gas temp.	-9,4	15	392,4	1340	337,7	2,18	7,45	1,88	180,0	2,12	4,49
RGT= 32/90	-3,9	25	483,0	1650	415,7	2,53	8,64	2,18	190,8	2,19	5,57
liquid temp	0	32	554,9	1895	477,6	2,82	9,62	2,42	197,0	2,23	6,44
Tliq= 45/113	7,2	45	708,7	2420	610,0	3,46	11,83	2,98	204,7	2,25	8,33
[°C / °F]	-35	-31	103,5	353	89,0	0,88	2,99	0,75	118,0	1,72	1,28
cond. pressure	-23,3	-10	185,6	634	159,7	1,21	4,13	1,04	153,6	1,88	2,31
pc= 55/131	-15	5	267,5	913	230,2	1,49	5,08	1,28	180,0	2,08	3,36
return gas temp	-9,4	15	335,3	1145	288,5	1,70	5,82	1,47	196,9	2,22	4,24
RGT= 32/90	-3,9	25	415,2	1418	357,3	1,95	6,67	1,68	212,5	2,35	5,30
liquid temp	0	32	479,0	1636	412,2	2,15	7,35	1,85	222,4	2,44	6,15
Tliq= 55/131	7,2	45	616,3	2105	530,4	2,59	8,86	2,23	237,7	2,56	8,03

**Model**

Designation	<b>DLE4CN</b>	<b>115V/60Hz</b>	<b>Conf. 3</b>	Sales code:	<b>102H3482</b>
-------------	---------------	------------------	----------------	-------------	-----------------

**Configuration**

Motorconfiguration	RSCR	
Power supply (nominal)	115V/60Hz 1~	
Refrigerant	R290	
Application	LBP+MBP	
Voltage range	95-135V	
Starting torque	LST	
Approvals	UL	SA3693
	CCC	

**Electrical accessories / wiring diagram**

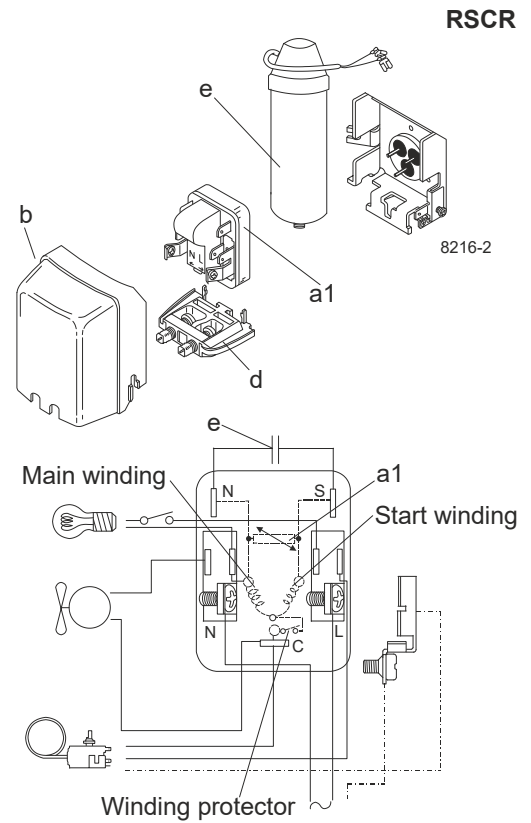

**Ambient temperatures / system cooling**

Ambient temperature min.:	10°C / 50°F
Ambient temperature max.:	43°C / 110°F

System cooling (n/a: outside limits)			
T ambient	LBP	MBP	HBP
32°C / 90°F	static	static	n/a
38°C / 100°F	static	static	n/a
43°C / 110°F	fan 3m/s	fan 3m/s	n/a

**Operation pressure range**

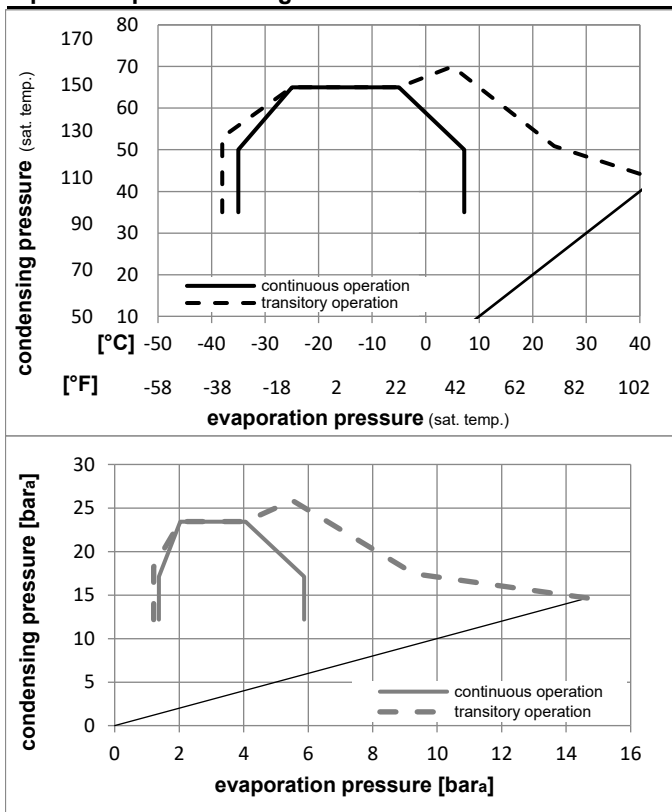

**Components**

a1	e-PTC starter	103N0058
e	run capacitor (15µF, 6.3mm)	117-7118
b	plastic cover	103N0492
d	cord relief	103N1010
	bracket for run capacitor	117-0300
	screw M4x8mm	117-0301

**Alternative components**

a1	e-PTC starter (115V, 50Ohm, 6.3mm, 4.8-cap)	103N0057
e	run capacitor (15µF, 4.8mm)	117-7120
b	plastic cover	103N0492
d	cord relief	103N1010
	bracket for run capacitor	117-0300
	screw M4x8mm	117-0301

**Model**

Designation **DLE4CN 115V/60Hz** Conf. **3** Sales code: **102H3482**

**Optimization + standard conditions**

115V/60Hz 1~, RSCR, fan 3m/s, UL, CCC

		Evaporating pressure (saturation temperature)				Condensing pressure (saturation temperature)						Power consumption			
		Return gas temp.		Liquid temp.		Cooling capacity				COP	EER	P1	Current consumption		Ref. mass flow
		pe	pc	RGT	Tliq	[W]	[Btu/h]	[kcal/h]	[W/W]	[Btu/Wh]	[kcal/Wh]	[W]	I	m	
[°C]	[°F]												[A]	[kg/h]	
-23,3	-10	54,4	130	32,2	90	233,9	799	201,3	1,58	5,40	1,36	147,8	1,33	2,37	ASHRAE LBP
-25	-13	55	131	32	89,6	175,1	598	150,7	1,22	4,17	1,05	143,4	1,29	2,18	cecomaf LBP
-35	-31	40	104	20	68	134,6	460	115,9	1,19	4,07	1,03	112,9	1,06	1,54	EN12900 LBP
-6,66	20	54,4	130	35	95	422,8	1444	363,8	2,19	7,49	1,89	192,9	1,74	4,82	ASHRAE MBP
-10	14	55	131	32	89,6	334,5	1142	287,9	1,81	6,17	1,56	185,1	1,67	4,23	cecomaf MBP
-10	14	45	113	20	68	376,4	1285	323,9	2,21	7,54	1,90	170,4	1,57	4,62	EN12900 MBP

**Performance tables**

115V/60Hz 1~, RSCR, fan 3m/s, UL, CCC

[°C / °F]	pe	Cooling capacity			COP	EER	P1	I	m		
	[°C]	[°F]	[W]	[Btu/h]	[kcal/h]	[W/W]	[Btu/Wh]	[kcal/Wh]	[W]	[A]	[kg/h]
-35	-31	128,3	438	110,4	1,12	3,82	0,96	114,6	1,07	1,44	
cond. pressure	-23,3	-10	225,3	769	193,9	1,59	5,44	1,37	141,6	1,30	2,54
pc= 45/113	-15	5	321,4	1097	276,6	2,01	6,85	1,73	160,2	1,47	3,66
return gas temp.	-9,4	15	400,3	1367	344,5	2,33	7,97	2,01	171,5	1,58	4,58
RGT= 32/90	-3,9	25	492,7	1683	424,0	2,72	9,29	2,34	181,2	1,66	5,68
liquid temp	0	32	566,0	1933	487,1	3,03	10,35	2,61	186,7	1,69	6,57
Tliq= 45/113	7,2	45	722,9	2469	622,2	3,73	12,74	3,21	193,8	1,71	8,49
-35	-31	105,5	360	90,8	0,91	3,09	0,78	116,6	1,08	1,30	
cond. pressure	-23,3	-10	189,3	646	162,9	1,28	4,36	1,10	148,1	1,33	2,36
pc= 55/131	-15	5	272,8	932	234,8	1,59	5,43	1,37	171,5	1,55	3,43
return gas temp	-9,4	15	342,0	1168	294,3	1,83	6,26	1,58	186,6	1,68	4,33
RGT= 32/90	-3,9	25	423,5	1446	364,4	2,11	7,21	1,82	200,7	1,80	5,40
liquid temp	0	32	488,5	1668	420,4	2,33	7,96	2,01	209,6	1,87	6,27
Tliq= 55/131	7,2	45	628,6	2147	541,0	2,81	9,59	2,42	223,8	1,96	8,19