

# ROBUST AND RELIABLE EVEN UNDER HARSH CONDITIONS

SECOP



FRK-G

## Commercial Applications

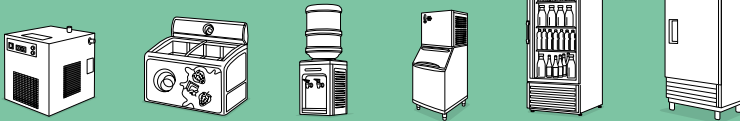

Master Voltage Fluctuations



Broad Application Range (L/M/HBP)



High Overload Robustness



Reduced Noise and Vibration



Excellent Efficiency

- **Heavy Duty Robustness**  
FRK-G compressors feature the tried and trusted quality of our FR compressors optimized for light commercial applications and for service and aftermarket use thanks to their insensitivity against oil traps
- **Robust Solution for Food Retail and Food Service Applications**  
Dedicated reliable design for bottle coolers, glass door merchandisers, and ice cream freezers and suitable for food service applications (LBP, MBP, and HBP applications)
- **Excellent Efficiency**  
High COP and top efficiency for light commercial applications
- **Optimized Muffler System**  
The new muffler feature minimizes the risk of compressor or system damage due to extreme liquid return conditions or oil foaming
- **Easier Application Assembly**  
New terminal board design for additional interconnections
- **Reduced Noise Level**  
Improved noise and reduced vibration

Secop's new **FRK-G** compressors are the successors of our legendary FR compressors (F-Series). These were one of the most robust compressors on the market, known for their reliability even under harsh conditions. The designation of the FRK compressors has been adapted to the F-Series to ensure comparability.

Secop has developed the robust new F-Series for commercial refrigeration, which integrates various technical innovations, such as a noise-reducing shell, robust suspension, a robust internal discharge tube, improved valves, optimized motors, and a new muffler for lower noise levels.

FRK-G compressors were developed to offer a reliable, top-performing, and cost-effective solution for the next generation of light commercial cabinets offering high energy efficiency.

FRK-G compressors are dual frequency (50/60 Hz) types and are designed to support regions that experience harsh and challenging environments and where voltage fluctuations as well as high ambient temperatures need to be taken into account.

FRK-G compressors have a muffler system specially developed for heavy duty applications with rapid load changes, extreme liquid return conditions, and oil foaming. It increases the robustness and reliability of the cooling system against this type of overload.

General	FRK5G	FRK6G	FRK7.5G	FRK8.5G	FRK10G	FRK11G
Compressor	106G5453	106G5553	106G5653	106G5753	106G5853	106G5953
Approvals (pending)	EN60335-1, EN 60335-2-34 with Annex AA, IEC/EN 60079-1, IEC/EN 60079-15					

Application	R134a					
Application	LBP/MBP/HBP	LBP/MBP/HBP	LBP/MBP/HBP	LBP/MBP/HBP	LBP/MBP/HBP	LBP/MBP/HBP
Evaporating temperature	°C	-35 to 15	-35 to 15	-35 to 15	-35 to 15	-35 to 10
Voltage range / frequency	V/Hz	187-254/50 198-253/60	187-254/50 198-253/60	187-254/50 198-253/60	187-254/50 198-253/60	187-254/50 198-253/60

Performance Data ASHRAE LBP (220 V, 50   60 Hz • fan cooling)						
Evaporating temp.	°C	-23.3	-23.3	-23.3	-23.3	-23.3
Cooling capacity	W	101   122	129   153	155   191	187   227	220   263
	BTU/h	344   417	439   523	530   653	640   776	750   900
Power consumption	W	89   102	103   119	119   140	147   167	167   191.48
COP	W/W	1.12   1.18	1.24   1.28	1.30   1.35	1.27   1.35	1.30   1.36
EER	BTU/Wh	3.83   4.03	4.23   4.36	4.42   4.60	4.32   4.60	4.45   4.65
Test conditions	Condensing temperature: 54.4°C   Suction gas temperature: 32.2°C   Ambient temperature: 32.2°C   Liquid temperature: 32.2°C					

Performance Data ASHRAE MBP (220 V, 50   60 Hz • fan cooling)						
Evaporating temp.	°C	-6.7	-6.7	-6.7	-6.7	-6.7
Cooling capacity	W	219   258	277   327	332   392	397   469	448   535
	BTU/h	748   883	945   1116	1132   1339	1355   1602	1529   1827
Power consumption	W	125   144	149   172	175   203	217   248	249   292
COP	W/W	1.73   1.78	1.84   1.88	1.88   1.91	1.81   1.87	1.78   1.82
EER	BTU/Wh	5.91   6.07	6.29   6.42	6.42   6.52	6.19   6.39	6.07   6.20
Test conditions	Condensing temperature: 54.4°C   Suction gas temperature: 35°C   Ambient temperature: 32.2°C   Liquid temperature: 46.1°C					

Performance Data ASHRAE HBP (220 V, 50   60 Hz • fan cooling)						
Evaporating temp.	°C	7.2	7.2	7.2	7.2	7.2
Cooling capacity	W	394   460	497   581	595   696	709   830	783   936
	BTU/h	1346   1572	1697   1985	2033   2375	2422   2836	2676   3197
Power consumption	W	154   180	185   217	220   258	277   319	328   384
COP	W/W	2.53   2.53	2.66   2.65	2.68   2.67	2.53   2.57	2.36   2.41
EER	BTU/Wh	8.64   8.65	9.08   9.06	9.16   9.13	8.65   8.79	8.07   8.24
Test conditions	Condensing temperature: 54.4°C   Suction gas temperature: 35°C   Ambient temperature: 32.2°C   Liquid temperature: 46.1°C					

Dimensions						
Height	mm	A	182			
		B	175			
Suction connector location	I.D. mm   angle material   seal	C	8.2   30°			
			Copper   Rubber plug			
Process connector location	I.D. mm   angle material   seal	D	6.2   35°			
			Copper   Rubberplug			
Discharge connector location	I.D. mm   angle material   seal	E	6.2   40°			
			Copper   Rubber plug			
Connector tolerance	I.D. mm	±0.09				

Variants with small baseplates available on request, please contact Secop for further information.

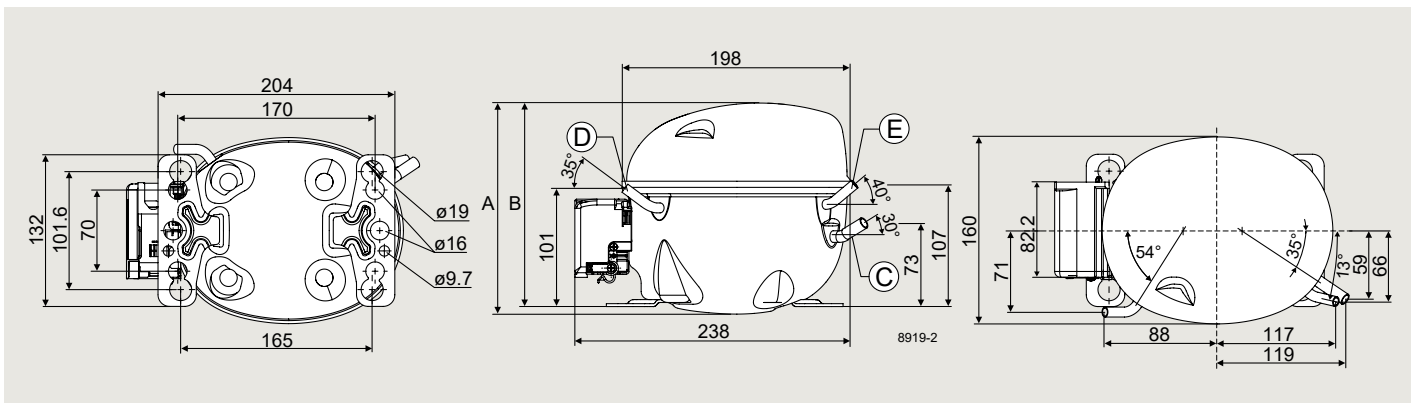

Secop GmbH · Lise-Meitner-Str. 29 · 24941 Flensburg, Germany · Tel: +49 461 4941 0 · [www.secop.com](http://www.secop.com)

Secop accepts no responsibility for possible errors in catalogs, brochures, and other printed material. Secop reserves the right to alter its products without notice. This also applies to products already on order provided that such alterations can be made without subsequent changes being necessary to specifications already agreed. All trademarks in this material are the property of the respective companies. Secop and the Secop logotype are trademarks of Secop GmbH. All rights reserved.