

R290 · 220–240V | 50Hz

COMBINING COMPACT SIZE WITH HIGH PERFORMANCE

SECCP



Max.
Performance

NLE Plus



Commercial
Applications

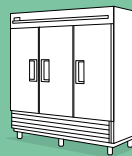
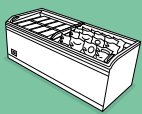

New Hermetic
Terminal Plug



Hot Gas
Defrost



High
Efficiency



Small
Footprint



R290
Green Refrigerant

- **Full Range**
 - Available in displacements of 11, 13, 14, and 15 cm³
- **Increased Cooling Capacity**
 - Extended displacement for a wider range of applications
- **First-Class Robustness**
 - Improved robustness for liquid return
 - Increased stability during defrosting by hot gas
 - Improved noise/vibration reduction compared to similar products
- **Optimized Electrical System (IP23 Protection Class)**
 - More compact, easier installation
 - Additional connections
 - Flexible configuration options
- **Innovative Solution for Flammable Refrigerants**
 - Innovative patented hermetic terminal plug
- **Multiple Conformity**
 - Natural refrigerant solution
 - Low GWP at maximum capacity
 - Regulatory compliance and environmentally friendly with R290

The new **NLE Plus** refrigeration compressor series from Secop expands the N-Series with propane models featuring displacements of 14 and 15 cm³. It combines compact size with high performance and is optimized for R290 (propane) to ensure high energy efficiency. This solution is perfect for applications such as supermarket refrigerators/freezers, stainless steel refrigerators/freezers, double glass door merchandizers, and much more.

Secop sets new standards in terms of compactness, cooling capacity and reliability with the NLE Plus series. It has been specially developed to support the new IEC approvals for HC refrigerant charges from 150g to 500g in commercial refrigeration systems and offers an ultra-compact hermetic compressor solution.

Secop NLE Plus compressors offer optimized start equipment and are resistant to extreme liquid refrigerant returns. The starting accessories include a highly integrated relay as well as starting and running capacitors. These components are compact and easy to install and come with integrated PTC and NTC to reduce peak currents and voltage spikes, which increases safety and service life.

In addition, the series is equipped with a patented Secop hermetic terminal plug that ensures safe use of the R290 refrigerant to prevent root causes of electrical arcs injection with flammable refrigerants.

General	NLE11MNDX	NLE13LNDX	NLE13MNDX	NLE14LNDX	NLE15LNDX
Compressor	105H7103	105H7301	105H7302	105H7402	105H7500
Compressor with pre-assembled start equipment	105H7113	105H7311	105H7312	105H7412	105H7510
Approvals	VDE				

Application	R290				
Application	MBP	LBP	MBP	LBP	LBP
Evaporating temperature	°C	-25 to 10	-40 to -5	-25 to 7.5	-40 to -5
Voltage range / frequency	V/Hz	198-254/50	198-254/50	198-254/50	198-254/50

Performance Data ASHRAE (220 V, 50 Hz • fan cooling)						
Evaporating temp.	°C	-6.7	-23.3	-6.7	-23.3	-23.3
Cooling capacity	W	999	611	1137	714	775
Power consumption	W	467	361	544	425	452
COP	W/W	2.14	1.69	2.09	1.68	1.71
Test conditions	Condensing temperature: LBP: 54.4 °C, MBP: 54.4 °C Suction gas temperature: LBP: 32.2 °C, MBP: 35 °C Ambient temperature: LBP: 32 °C, MBP: 32 °C Liquid temperature: LBP 32.2 °C, MBP: 46.1 °C					

Performance Data CECOMAF (220 V, 50 Hz • fan cooling)						
Evaporating temp.	°C	-10	-25	-10	-25	-25
Cooling capacity	W	800	460	906	537	585
Power consumption	W	447	349	516	411	436
COP	W/W	1.79	1.32	1.75	1.31	1.34
Test conditions	Condensing temperature: LBP: 55 °C, MBP: 55 °C Suction gas temperature: LBP: 32.2 °C, MBP: 32.2 °C Ambient temperature: LBP: 32 °C, MBP: 32 °C Liquid temperature: LBP 55 °C, MBP: 55 °C					

Performance Data EN 12900 (220 V, 50 Hz • fan cooling)						
Evaporating temp.	°C	-10	-35	-10	-35	-35
Cooling capacity	W	874	355	1015	401	438
Power consumption	W	404	256	463	297	318
COP	W/W	2.17	1.38	2.19	1.35	1.38
Test conditions	Condensing temperature: LBP: 40 °C, MBP: 45 °C Suction gas temperature: LBP: 20 °C, MBP: 20 °C Ambient temperature: LBP: 32 °C, MBP: 32 °C Liquid temperature: LBP 40 °C, MBP: 45 °C					

Dimensions					
Height	mm	A	209		
		B	203		
Suction connector location	I.D. mm angle material seal	C	8.2 15° Copper Rubber plug		
Process connector location	I.D. mm angle material seal	D	6.2 25° Copper Rubber plug		
Discharge connector location	I.D. mm angle material seal	E	6.2 21° Copper Rubber plug		
Connector tolerance	I.D. mm	±0.09			

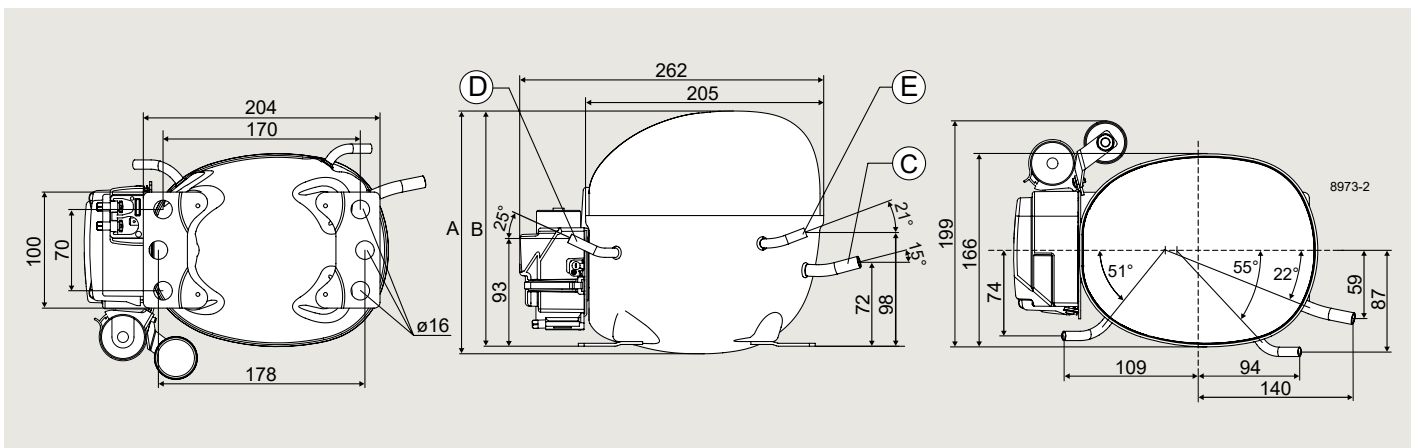

Secop GmbH · Lise-Meitner-Str. 29 · 24941 Flensburg, Germany · Tel: +49 461 4941 0 · www.secop.com

Secop accepts no responsibility for possible errors in catalogs, brochures, and other printed material. Secop reserves the right to alter its products without notice. This also applies to products already on order provided that such alterations can be made without consequential changes being necessary to specifications already agreed. All trademarks in this material are the property of the respective companies. Secop and the Secop logotype are trademarks of Secop GmbH. All rights reserved.