

Tailored for Vaccine Refrigerators

# SOLAR DIRECT DRIVE AND WEAK GRID POWER MANAGEMENT SYSTEM

SECCP



SDD Power Management Module · Solar 1 Controller · MB3CKV Compressor



Medical  
Cooling



Vaccine Transport  
and Storage



Weak Grid Protection  
up to 510 V



Wide AC  
Input Range



Solar Maximum  
Power Point Tracking



Wide Photovoltaic  
Panel Range  
Supported



PV Direct  
Input

- AC/DC solution optimized for photovoltaic solar panel supply and weak AC grid installations
- Increased maximum PV voltage to 55 V to enable the use of popular PV modules
- Power input management and peak power point tracking to ensure efficient and optimal use of PV energy
- Enhanced communication interface for operation and monitoring
- AC wide working range between 85 V and 264 V
- Additional 24 V DC output suitable for data loggers, monitoring devices, USB chargers, and external auxiliaries
- Designed for premium robustness and reliability: IP60 housing and robust against EMI
- Designed in combination with the new MB3CKV version of the BD Nano premium series compressor: premium cooling performance with the best efficiency
- Tailored to WHO PQS requirements and monitoring systems

The new solar direct drive (SDD) and weak grid power management system designed by Secop consists of the new generation **SDD Power Management Module**, the new **MB3CKV** medical version of the BD Nano compressor series, and its dedicated **Solar 1** controller.

It was specifically developed for applications operating with solar panels or in unstable and weak AC grids. The new SDD Power Management Module features a wide range AC input, to allow world-wide usage and is optimized for DC for widely diffused PV panels up to 72 cells for effective installations. The PV input features a MPPT algorithm that optimizes the compressors speeds to the available sunlight to gain the most cooling from the available PV energy.

A communication interface for master controllers and data loggers gives users full control over the appliance. The module can be easily monitored with the support of Secop's Tool4Cool® software.

The design of the new Power Management Module offers a premium robustness for reliable applications, including an IP60 housing and certified EMI enhanced robustness.

# A NEW SOLUTION DEVELOPED TO MEET WHO PQS



## Tailored to WHO PQS Specifications

Secop collaborated with Global Health Labs on the requirements definition and development of the SDD Power Management Module. The module is tailored to the WHO PQS specifications and meets all demands for solar direct drive as well as wide range and unstable power grids along with weak installations, to enable vaccine refrigerator manufacturers to satisfy the latest voltage stabilization requirements. The new SDD Power Management Module is the perfect choice for off-grid and weak-grid vaccine refrigerators, solar off-grid coolers and freezers, and ice bank refrigerators.

## Designed and Optimized for the New BD Nano-Series

The **SDD Power Management Module** is paired with the new **MB3CKV** compressor and its controller **Solar 1** to combine all the new features of an AC/DC system with the new generation of mobile cooling compressors: compact size, high efficiency for low energy consumption, low noise and low vibration, low GWP green refrigerants.

### MB3CKV Medical Compressor Features

- Compact size
- Robust design for mobile applications
- Protection against electromagnetic interference
- Tailor-made configurations
- Premium high efficiency
- Extended cooling capacity
- Reduced noise and vibrations
- Multiple compliance options



World Health Organization



Possible Project Savings

- The new SDD Power Management Module solution is tailored to the WHO PQS specifications E006
- It enables vaccine refrigerator manufacturers to satisfy the latest E007/VS0 1.6 voltage stabilization requirements

## Improvements for System Integrators

Integrated protection against dangerous and variable AC conditions known to permanently damage equipment	✓
Common compressor for AC and solar applications resulting in fewer components and cabinet configurations	✓
Significant reduction of project times and time to market	✓
Integrated data output compliant to WHO monitoring requirement	✓
Improved efficiency in variable solar conditions reduce the required solar panel capacity	✓

## Easy Field Installations



**Flexible Connections**  
Fridges can be used with either DC or AC power supply.



**Easier Maintenance**  
Simple connections and standard PV panels.

# NEW SDD POWER MANAGEMENT MODULE

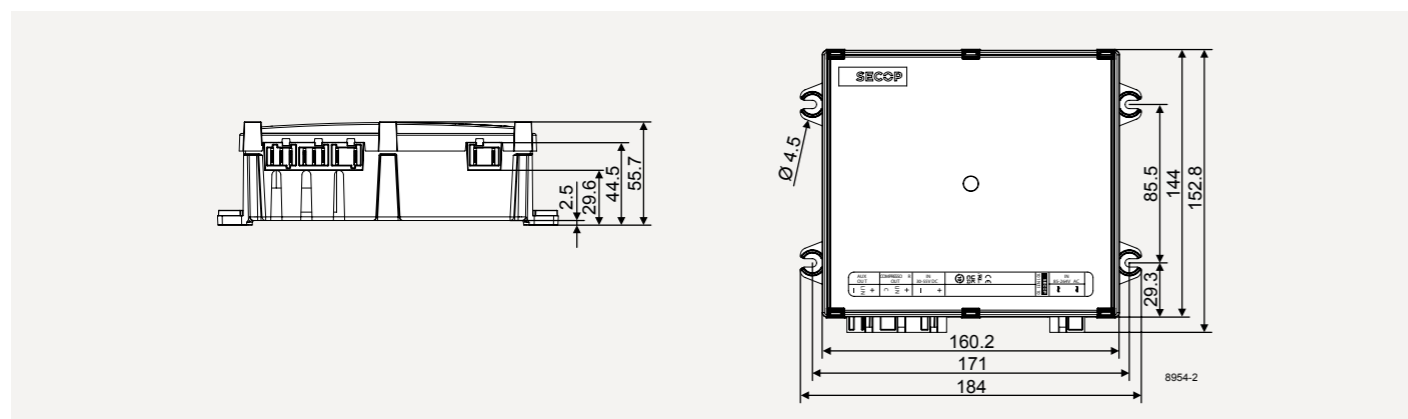
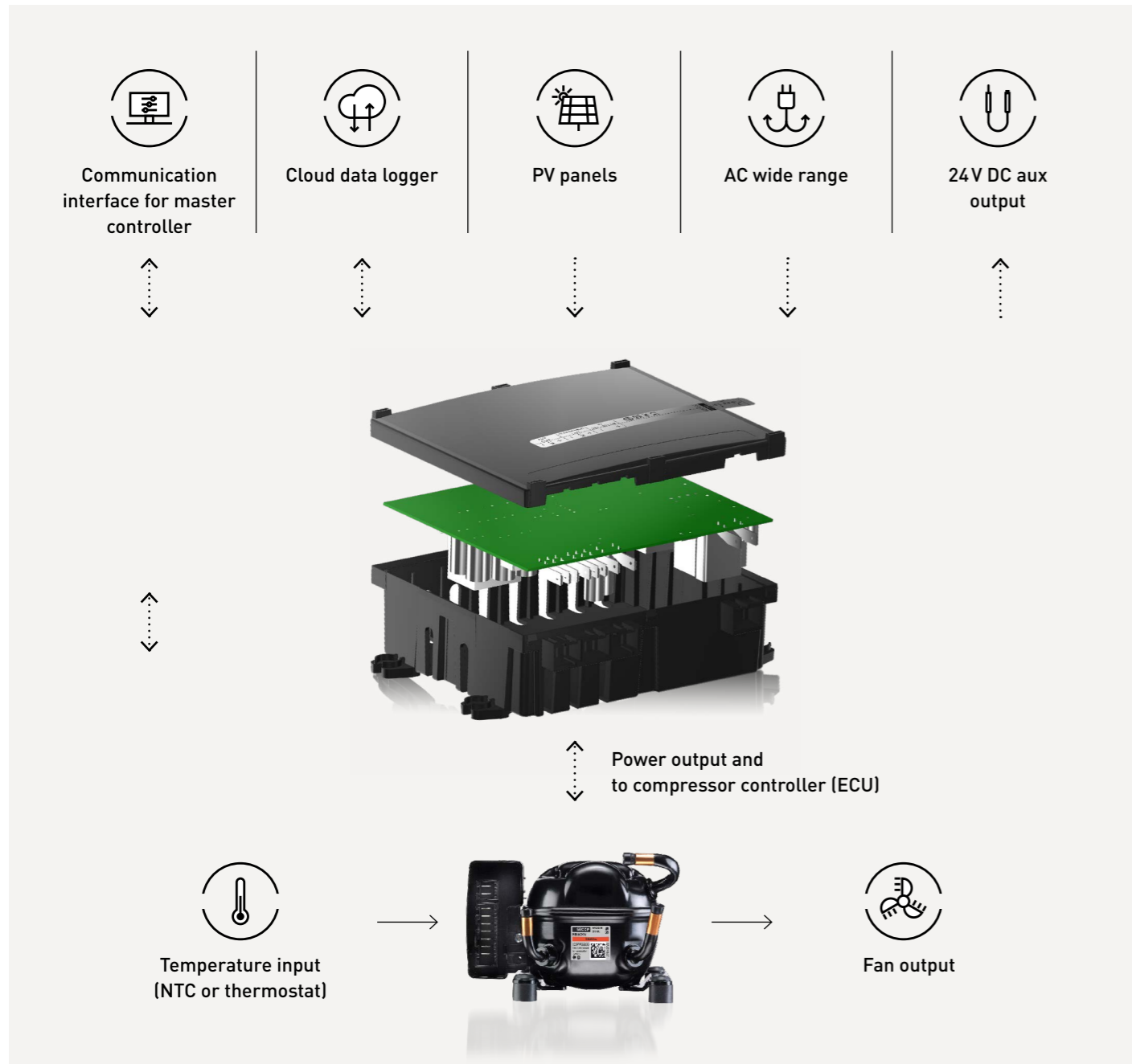

# PV DIRECT INPUT

# WIDE RANGE AC INPUT



- **Optimized input range** from 30–55 V to support up to latest generation of 72 cell PV panels
- **MPPT compressor speed control** to ensure best cooling performances
- **Reduced compressor start energy** for early morning and cloudy weather starts
- **WHO PQS EMS family standards compliant:**
  - E006/DL01 (data logger device)
  - E007/DS01 (data standard)

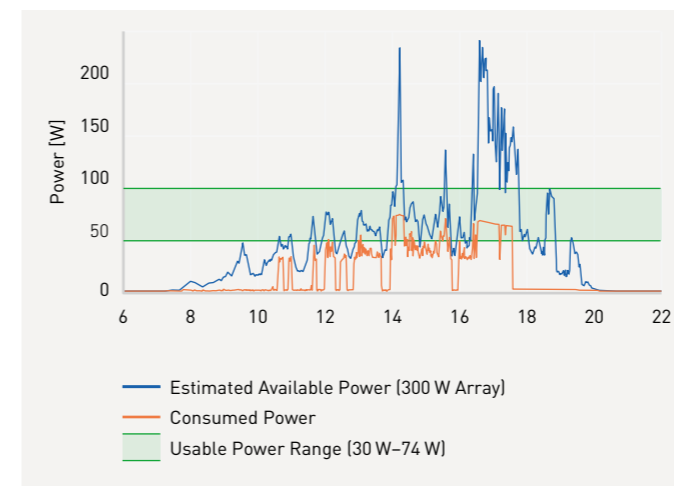

- **Wide range input** – working from 82 V to 274 V AC and 40 Hz up to 65 Hz. Protected up to 510 V AC (none-working).
- **No need for voltage stabilizer** – reduced complexity and cost.
- **Capable to deliver up to 110 W constantly** – independent from input voltage.
- **Lower power consumption** compared to previous BD-P solutions – due to increased COP therefore less operating time.
- **Lower starting power** – enables operating in grid networks with limited power supply.

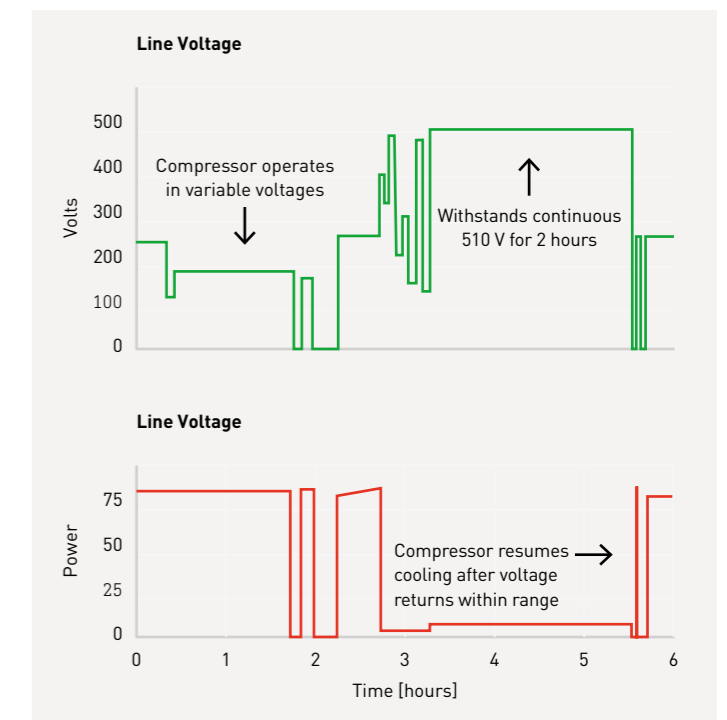

# TWO GENERATIONS OF BD COMPRESSORS FOR ISOBUTANE IN COMPARISON

Secop, the leading supplier of solar direct drive solutions, has developed a new generation **SDD Power Management Module** optimized for the new BD Nano-Series and especially the medical variant MB3CKV. The new module has been improved to better operate with photovoltaic panels and offers additional features. In combination with the new R600a mobile medical compressor MB3CKV, this technology offers a much higher cooling performance with the best efficiency compared to our former BD35K or BD50K solutions.

Compressor	Refrigerant	Application	Displacement [cm <sup>3</sup> ]	Capacity ASHRAE LBP [W]	COP ASHRAE LBP [W/W]	Speed range [rpm]	Height incl. feet and controller [mm]	Height incl. controller [mm]	Weight incl. controller [kg]
<b>MB3CKV</b>	R600a	LBP/MBP	2.6	68.1	1.54	2300-4500	93.3	82.4	1.5
<b>BD35K</b>	R600a	LBP/MBP/HBP	3.0	49.0	1.13	2000-3500	144.6	135	4.5
<b>BD50K</b>	R600a	LBP/MBP/HBP	3.0	57.2	1.08	2500-4400	144.6	135	4.5

Test conditions: Evaporating temp: -23.3°C | Condensing temp. 54.4°C | Suction gas temp. 32.2°C | Ambient temp. 32.2°C | Liquid temp. 32.2°C | Max. speed

## SMALL FOOTPRINT



## R600a - Performance @ ASHRAE LBP

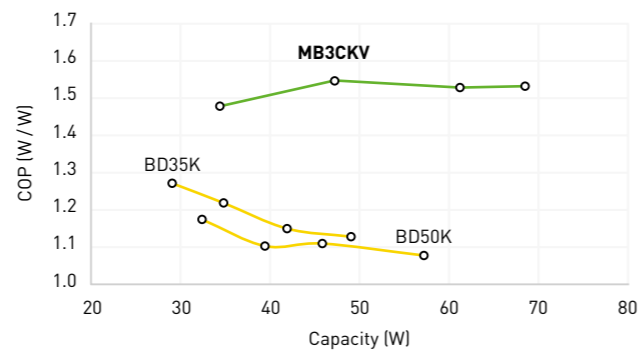

Features	101N0420 for BD-P (BD35K or BD50K)	101N3110 for MB3CKV (w. 101N2742)
PV input range	10 V-45 V	25 V-57 V
AC input range	No AC input	0V-510 V, 40Hz-65 Hz
AC working range	No AC input	85V-264 V
Communication	Modbus communication	Modbus communication
Suitable compressors	BD P-housing	BD Nano
PV panel requirement	4x 90 W	1x 160 W, 72 cell recommended, 60 Cell supported
Required starting power	70 W	40 W
Communication port	Secop D/I standard	Industry Standard LIN
MPPT	⊘	☑
Wide range AC input	⊘	☑
AC surge protection	⊘	☑
Standard, locking connectors with coding	⊘	☑
Configurable 24 V aux output	⊘	☑
Available parameters	Main Switch, Compressor Speed, Fan Speed, AEO, Thermostat, Communication	Main Switch, Compressor and Fan Speed, MPPT Operation, AC Boundaries, Communication Settings, AUX Settings, Thermostat settings. Log parameters to support vaccine refrigerators according WHO EMS standards.

# TECHNICAL DATA MB3CKV WITH CONTROLLER SOLAR 1

General	MB3CKV
Refrigerant	R600a
Compressor (1.37 kg)	109M0860
Controller - Solar 1 (0.14 kg)	101N2742
Approvals	UL, CB

Application	
Application	LBP/MBP
Evaporating temperature	°C -30 to 5
Voltage range	VDC 9.6-17 / 19-34
Speed range	rpm 2300-4500

## Performance Data ASHRAE LBP (12 V DC • static cooling) @ -23.3°C evaporating temperature

	rpm	2300	3000	4000	4500
Speed	rpm	2300	3000	4000	4500
Cooling capacity	W	31.6	43.9	60.2	68.1
Power consumption	W	21.4	28.2	39.3	44.3
COP	W/W	1.48	1.56	1.53	1.54
Test conditions	Condensing temperature: 54.4°C   Suction gas temperature: 32.2°C Ambient temperature: 32.2°C   Liquid temperature: 32.2°C				

## Performance Data EN 12900 Household/CECOMAF (12 V DC • static cooling) @ -25°C evap. temp.

	rpm	2300	3000	4000	4500
Speed	rpm	2300	3000	4000	4500
Cooling capacity	W	25.6	35.2	45.4	50.8
Power consumption	W	20.2	26.6	36.9	41.8
COP	W/W	1.16	1.23	1.21	1.20
Test conditions	Condensing temperature: 55°C   Suction gas temperature: 32°C Ambient temperature: 32°C   Liquid temperature: no subcooling				

## Dimensions

Height	mm	A	89.0
		B / B1 / B2	82.4 / 48.7 / 45.8
Suction connector	location/I.D. mm   angle material   seal	C	6.2   5° Copper   Rubber plug
Process connector	location/I.D. mm   angle material   seal	D	6.2   77.9° Copper   Rubber plug
Discharge connector	location/I.D. mm   angle material   seal	E	5.0   86.9° Cu-plated steel   Rubber plug
Connector tolerance	I.D. mm		±0.09, on 5.0 +0.12/+0.20

## Controller 101N2742 Features

New 32-bit microcontroller STM32	Parameters accessible in SI units · quicker response times · class B software for easier CB approval
Dedicated fan converter hardware	Stable fan output voltage · no fan noise changes · perfect fan protection
LIN communication hardware	Standard transceivers · robust against ground voltage shift and EMI · Modbus protocol
Updated hardware design and components	Minimal additional EMI filtering required · state of the art components · long term availability
Improved housing design	Optimized airflow · optimized PCB position · enforced stability for protection against rough conditions
Coded connectors with RAST hook	Withstand high pull forces · prevent wrong insertion · smart grouping eases wiring
Easier mounting	Fixed motor connector (snap on) · one-hand mounting without screwdriver · optional screw

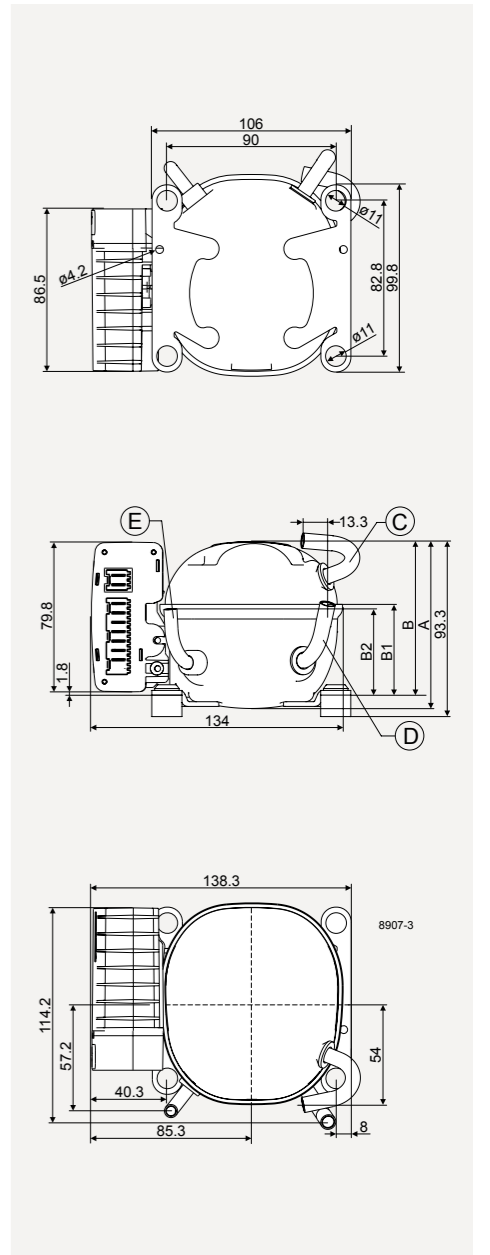



# Tool4Cool® SOFTWARE INTERFACE

Tool4Cool® is a unique PC software tool that enables users to precisely configure Secop BD compressors to the desired cooling systems.

Via microprocessor-based controllers, Tool4Cool® provides users with easy access to all parameters. These can be changed, monitored, downloaded, or uploaded to get the optimum performance out of your cooling system.

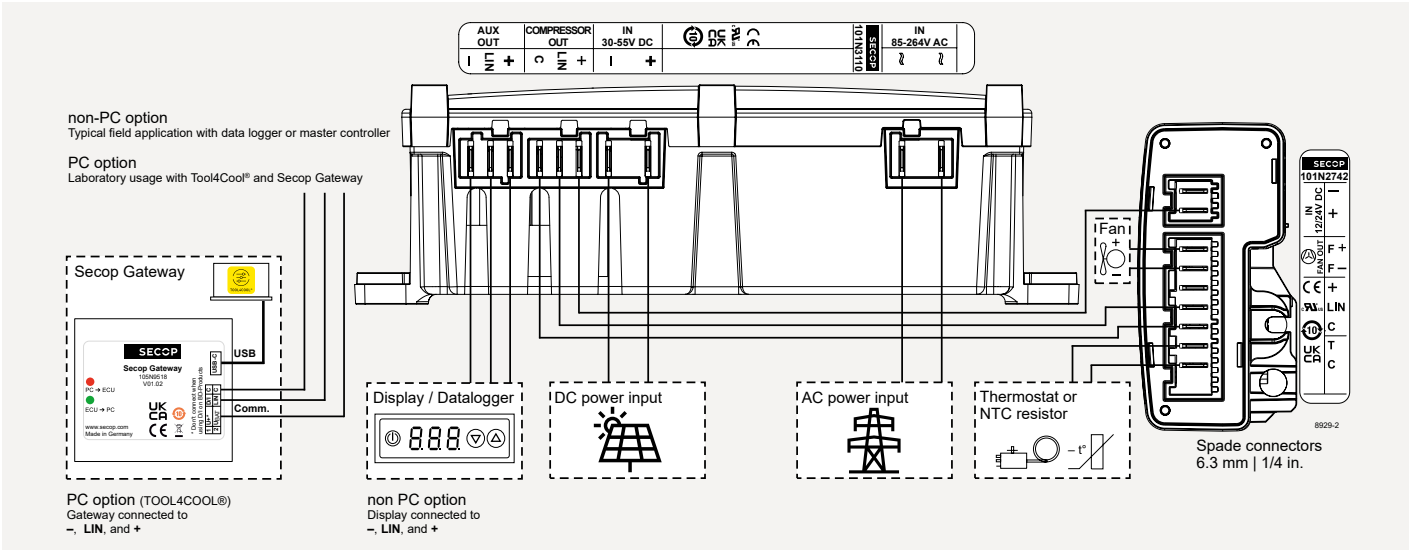

## MEDICAL COMPRESSORS PORTFOLIO

Sub Platform	Applications Evap. Temp Range	Displacement (cm <sup>3</sup> )	Cooling Capacity (W)	Test Conditions	Refrigerants
MB CKV	Solar Powered Vaccine Refrigerators -30 to 5° C	2.6	66-133	ASHRAE MBP	R600a
MN U/UV	Biomedical Freezers -30 to -60° C	11.15-12.55	245-538	EN 12900 LBP	R290
MS U/UV	Biomedical Freezers -30 to -60° C	17.69-20.95	316-657	EN 12900 LBP	R290
MP UV	Ultra-Low Temperature Freezers -60 to -90° C	2	26.7-47	pe= -90° pc= -35° Tsuc= 20° Tliq= -35° Tamb= 32.2°	R170 R290
MN U/UV	Ultra-Low Temperature Freezers -60 to -90° C	11.15-12.55	182-397	pe= -90° pc= -35° Tsuc= 20° Tliq= -35° Tamb= 32.2°	R170 R290 R1270
MS U/UV	Ultra-Low Temperature Freezers -60 to -90° C	17.69-20.95	234-477	pe= -90° pc= -35° Tsuc= 20° Tliq= -35° Tamb= 32.2°	R170 R290 R1270
ULT Condensing Units	Ultra-Low Temperature Freezers -60 to -90° C	2-17.69	26.7-477	pe= -90° pc= -35° Tsuc= 20° Tliq= -35° Tamb= 32.2°	R170 R290 R1270

Secop GmbH · Lise-Meitner-Str. 29 · 24941 Flensburg, Germany · Tel: +49 461 4941 0 · [www.secop.com](http://www.secop.com)

Secop accepts no responsibility for possible errors in catalogs, brochures, and other printed material. Secop reserves the right to alter its products without notice. This also applies to products already on order provided that such alterations can be made without subsequent changes being necessary to specifications already agreed. All trademarks in this material are the property of the respective companies. Secop and the Secop logotype are trademarks of Secop GmbH. All rights reserved.