

CORE FUNCTIONS CONTROLLERS FOR NLV-CN COMPRESSORS



105N4120 Core Functions · 220-240V | 50/60 Hz



Variable-Speed Efficiency

Core Functions Controller

Commercial Applications

TABLE OF CONTENTS

- 1. Installation** 4
 - 1.1 Airflow 5
 - 1.2 Earthing the Compressor and Controller 5
 - 1.3 Wiring Diagram 6
 - 1.4 Connections 6
 - 1.5 Wiring for Thermostatic Operation 7
 - 1.6 Wiring for Frequency Operation/DWI Communication 7

- 2. Speed Control** 8
 - 2.1 Thermostatic Operation with AEO. 9
 - 2.2 Frequency Speed Control 10
 - 2.3 DWI Serial Communication 11
 - 2.4 Defrost Control with AEO 12

- 3. Technical Data** 13
 - 3.1 Controller Data 14
 - 3.2 Compressor Data 14
 - 3.3 Capacity and Performance Data NLV8.0CN 15
 - 3.4 Capacity and Performance Data NLV10CN 15
 - 3.5 Capacity and Performance Data NLV12.6CN 15

- 4. Dimensions** 16

- 5. Ordering** 17



1

INSTALLATION

WARNING!

R290

To remove a compressor from a system the tubes must be cut.
Never use a torch to remove brazed tubes.

Brazing on Suction Connectors (Direct Intake)

representative image

! max. 150°C/302°F !
at socket
brazing solder: phosphor (LP7) or silver

Refer to Product Bulletin:
Brazing on Suction Connectors
(Compressors with Direct Suction Intake)

1.1 Airflow

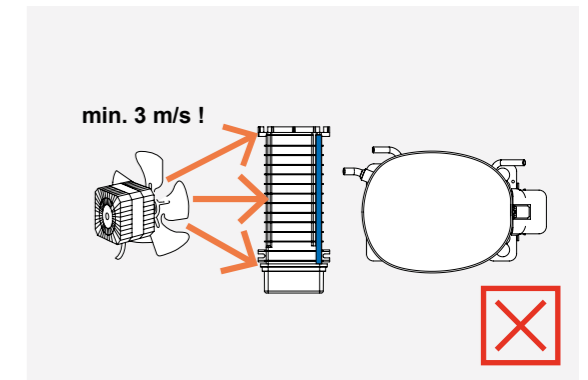
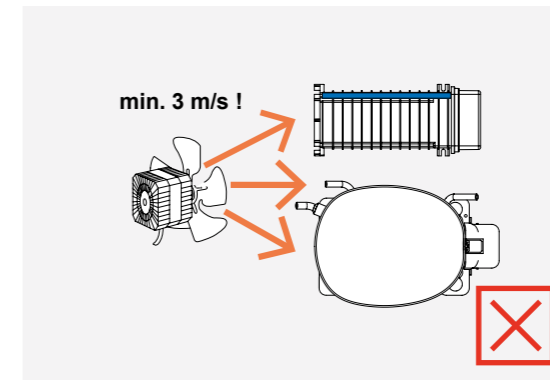
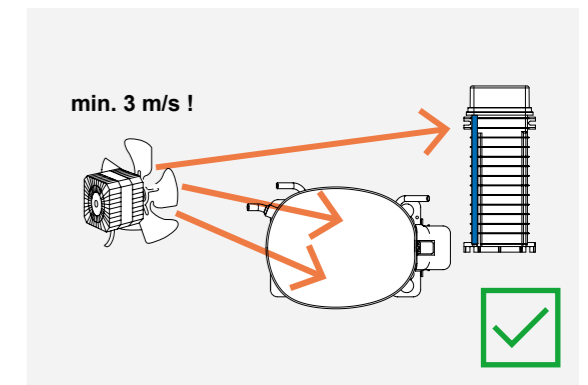
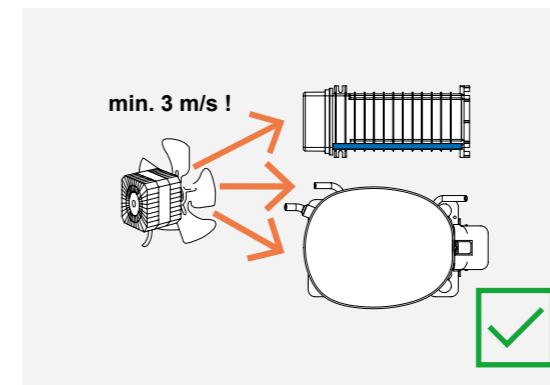
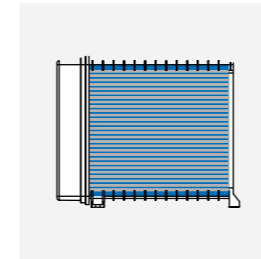

Ensure proper airflow of 3 m/s at both compressor and electronic units.
The airflow for the electronics must be directed to the heat sink.

1.2 Earthing the Compressor and Controller

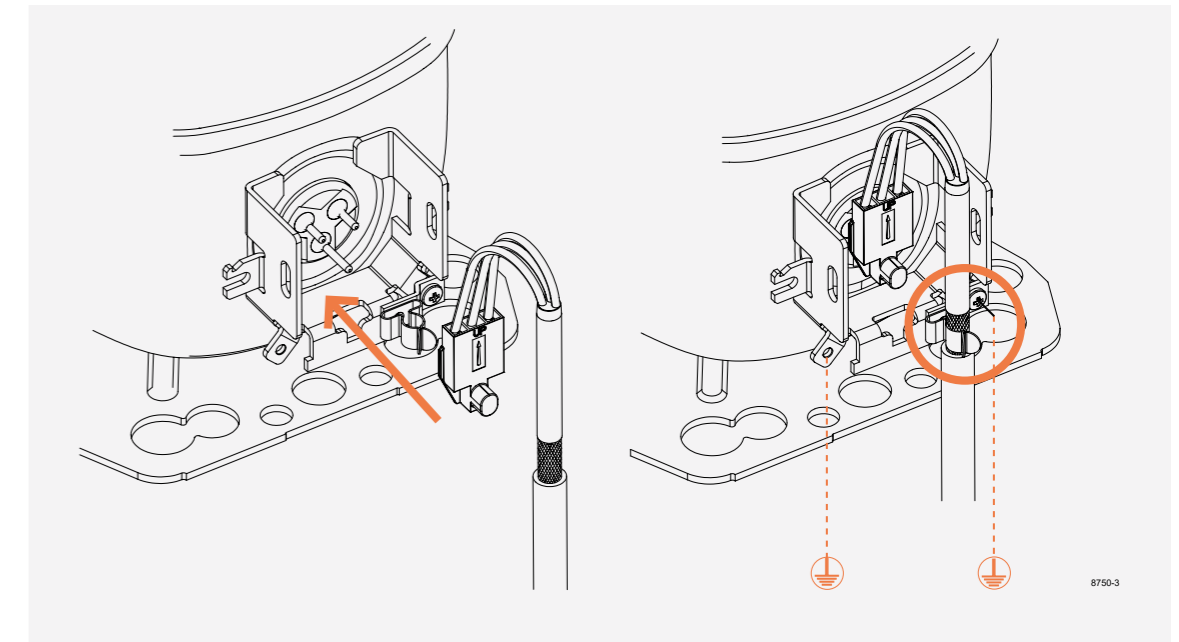

- For optimum EMC performance, the copper shield of the controller cable must be fastened properly in the clip at the compressor.
- Compressor and controller must be connected to PE (Protective Earth) to avoid risk of electrical hazard.
- All protective earth lines, PE, in the application must be collected to one star point. This prevents loop currents which could cause problems concerning the electronic components, communication lines, and sensors. The star-point is normally a screwed terminal on the chassis.

1.3 Wiring Diagram

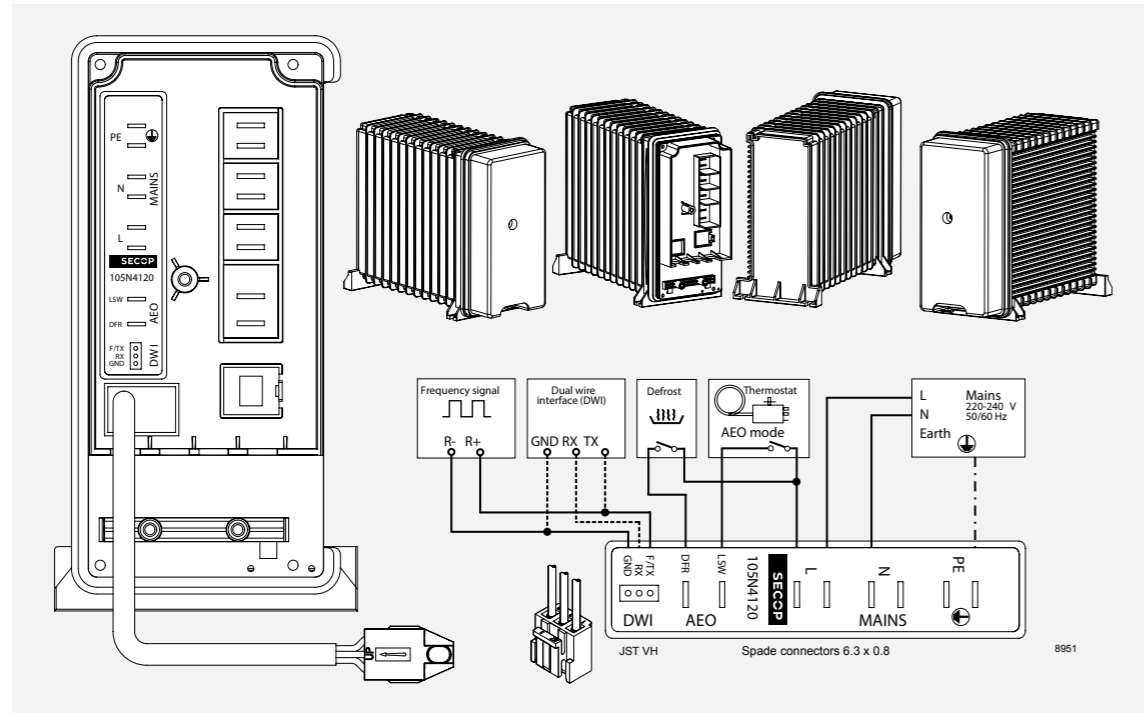

- Installation must only be done by trained personal.
- Do not remove the cover of the controller when the unit is powered on.
- Disconnect from power and wait 30 seconds before accessing terminals.
- The maximum cable length should not exceed 3 meters for signal connections. A cable length of more than 3 m could alter the EMI performance.
- Signal lines must be separated from power lines.

1.4 Connections



- ① 2x Protective Earth
- ② 2x Neutral
- ③ 2x Line
- ④ Thermostat/AEO
- ⑤ Defrost
- ⑥ Frequency and DWI

No.	Description	Type	Note
1	Protective Earth	FASTON 6.3 mm × 0.8 mm	Mandatory, must be connected
2	Neutral	FASTON 6.3 mm × 0.8 mm	Mandatory, must be connected
3	Line	FASTON 6.3 mm × 0.8 mm	Mandatory, must be connected
4	Thermostat	FASTON 6.3 mm × 0.8 mm	For AEO only
5	Defrost	FASTON 6.3 mm × 0.8 mm	For AEO and defrost only
6	Frequency/DWI	JST VH	For frequency or DWI only

1.5 Wiring for Thermostatic Operation

For optimal hot-gas defrost performance, the relay output of the controller should be connected to the DEF input of the controller. This ensures that the compressor operates at full speed when the hot-gas valve is activated.

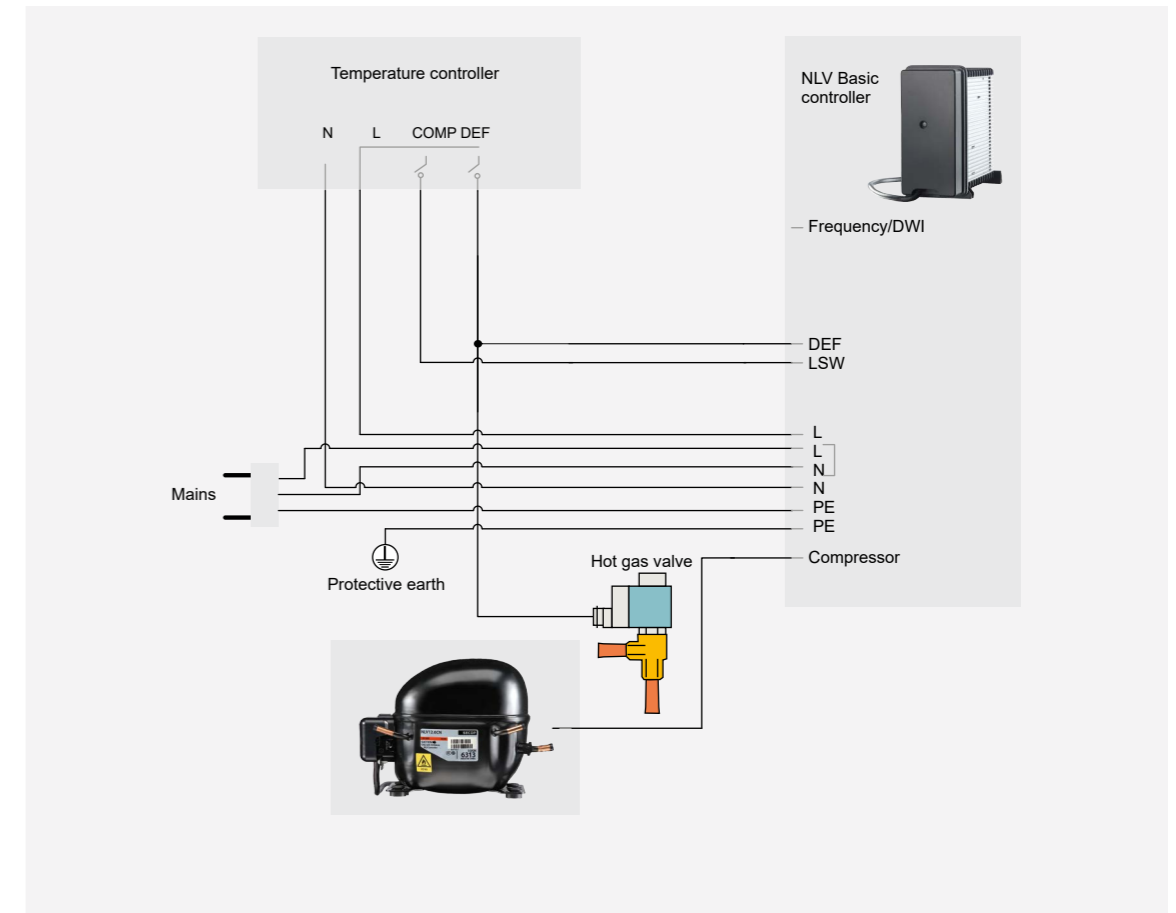

1.6 Wiring for Frequency Operation/DWI Communication

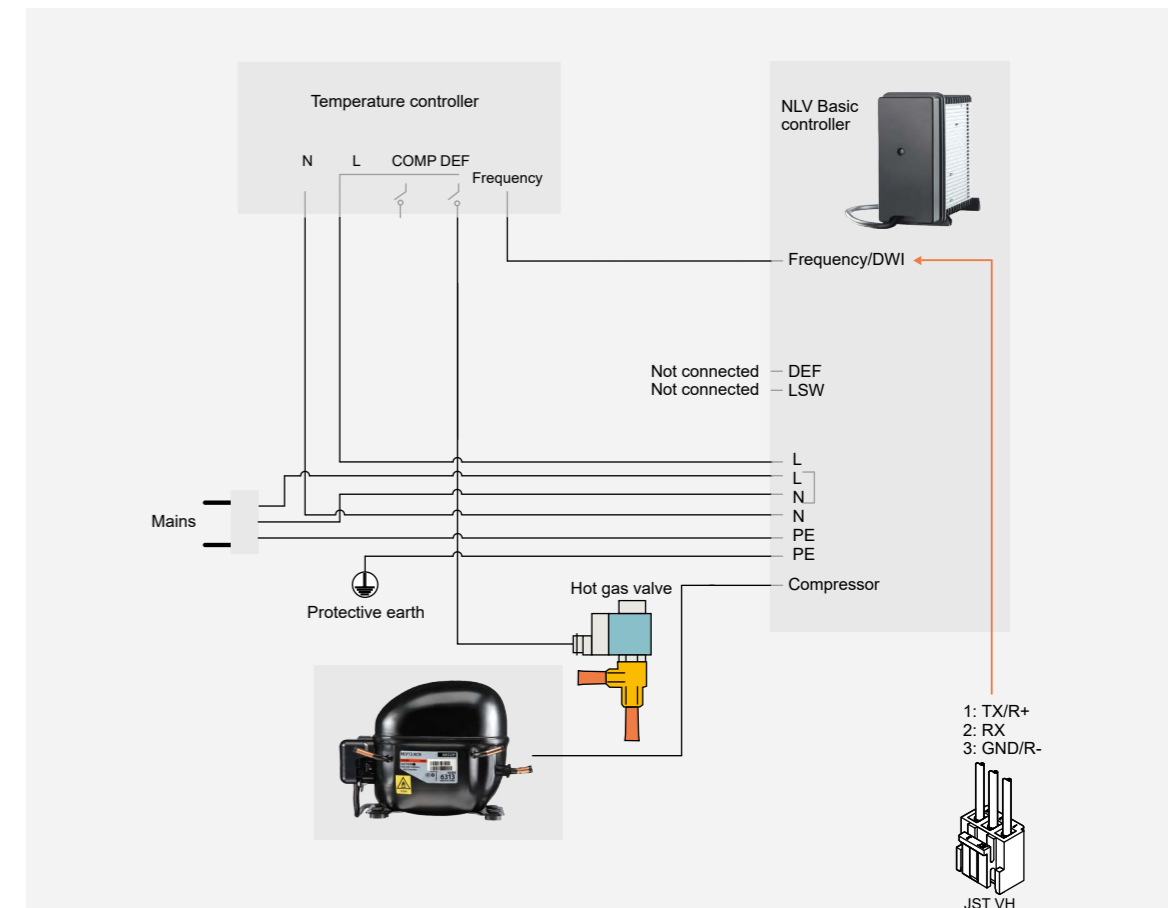

2

SPEED CONTROL

The Secop Core Functions controller is equipped with three different inputs for speed control to ensure easy integration.

Almost any temperature controller can be used to control the speed without needing to change the setup. The Core Functions controller has automatic input detection and will automatically select the input which is active.

1. Frequency signal.
2. Thermostatic operation with AEO, Adaptive Energy Optimization.
3. DWI, Dual Wire Interface with separated RX and TX lines.

- If more signals are connected, the input with highest priority (1–3) will be used.
- DWI input has the lowest priority and can be used for monitoring in combination with the other inputs.
- If DWI sends an active start command, the DWI input will change priority to 1 and overrule all other input signals.



2.1 Thermostatic Operation with AEO

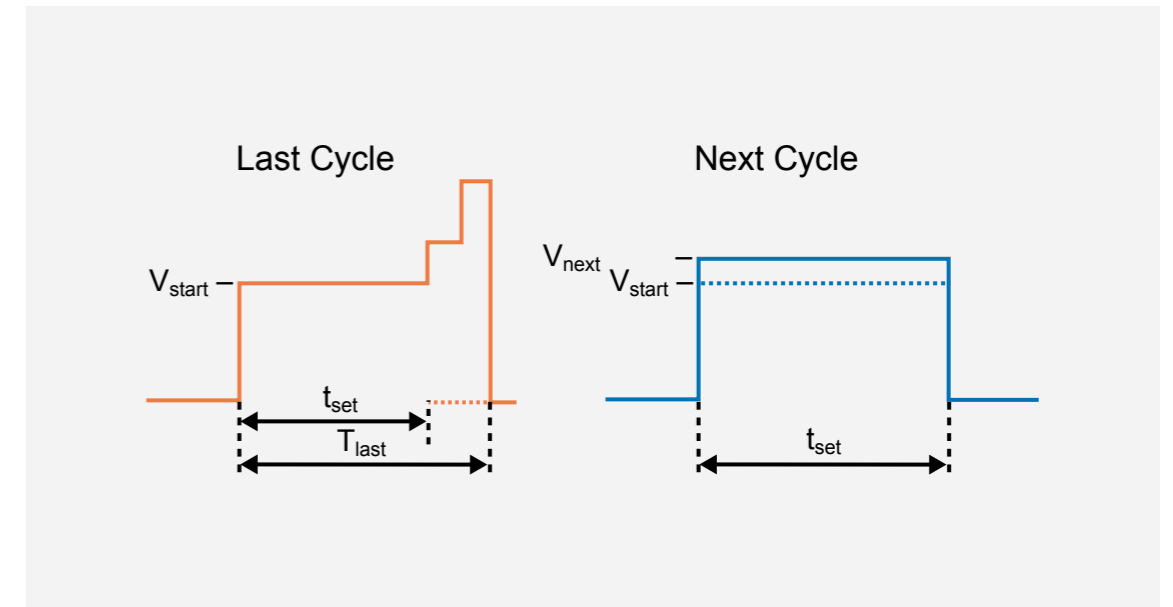

AEO is the only control mode where there is no direct relation between speed and input signal. The speed is automatically calculated based on the runtime (time between cut-in and cut-out).

The AEO can be interfaced by a normal thermostat or relay.

Advantages of the AEO:

- Easy to interface.
- Mechanical thermostat.
- Electronic control with relay output.
- Perfect for applications with stable conditions, such as freezers, catering equipment.

The AEO operates with a target runtime and will automatically adapt the speed until the target runtime is met.

- If the compressor runtime is shorter than the target time, the speed in the next cycle will be reduced.
- If the runtime is longer than the target time, the speed in the current cycle will be increased until the cut-out is reached. The next cycle is calculated as the average speed for the last cycle.

% Runtime	% Speed
100	105
110	110
120	120
140	130
160	140
190	180
220	225

2.2 Frequency Speed Control

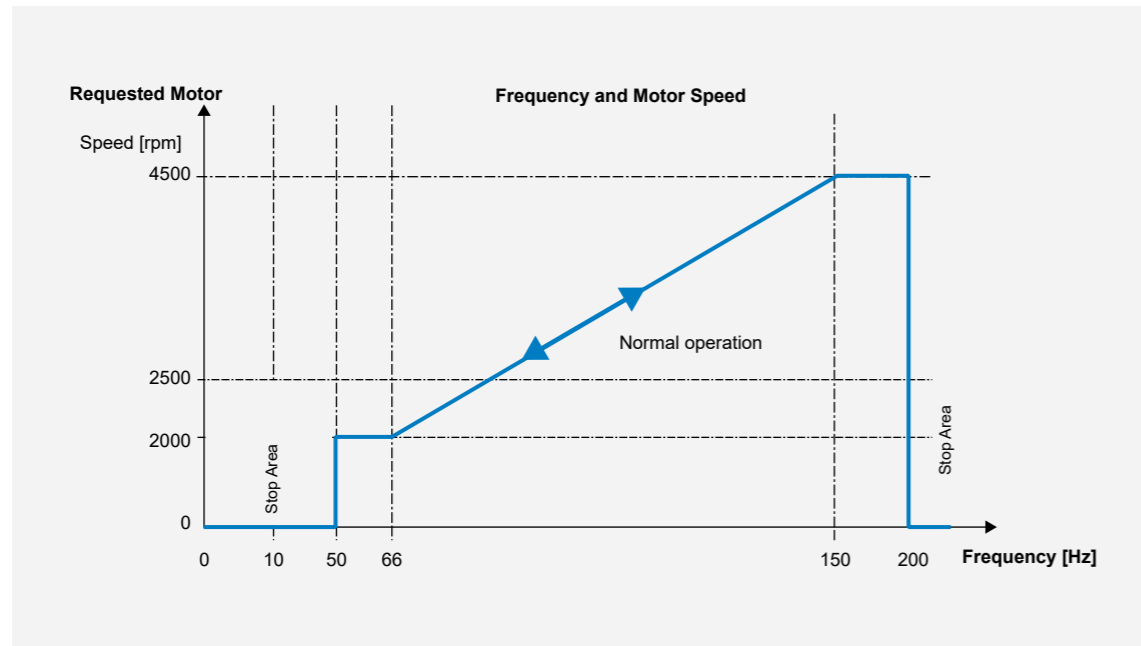

- The speed can be controlled by applying a low voltage frequency signal to the frequency input
- The speed is changed linearly between 66 Hz and 150 Hz.
 - The frequency of 66 Hz corresponds to 2000 rpm, 150 Hz to 4500 rpm (30 rpm/1 Hz by default).
 - If the frequency is between 10-50 Hz, the compressor stops.
 - The frequency signal should have a voltage of 5–12 V and a duty cycle of 50%.

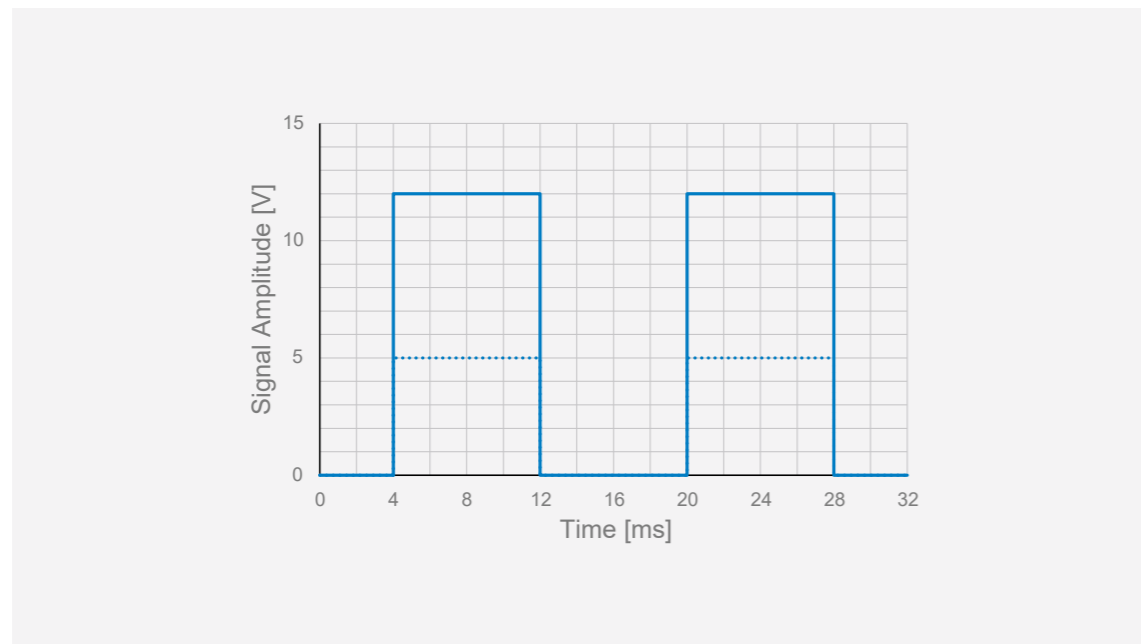

2.3 DWI Serial Communication

Communication Specification	
Baud Rate:	600 Baud
Start Bits:	1
Data Bits:	8
Stop Bits:	1
Parity:	No
Frame Size:	5 Bytes
Appliance Controller:	Master
Compressor Controller:	Client
Start Bit:	1 → 0 (logic level)
Data Bits:	Inverted logic (0V → "1")
Stop Bit:	0 → 1 (logic level)
Control Mode:	Half duplex

The DWI, Dual Wire interface, is a bidirectional communication protocol that allows the temperature controller to communicate with the compressor controller.

In addition to speed, the temperature controller can get different information from the controller, such as power-consumption, actual speed, electronic temperature, and fault status.

The communication interface is shared with the frequency interface. A full description of the interface and a list of supported commands may be requested from Secop.



2.4 Defrost Control with AEO

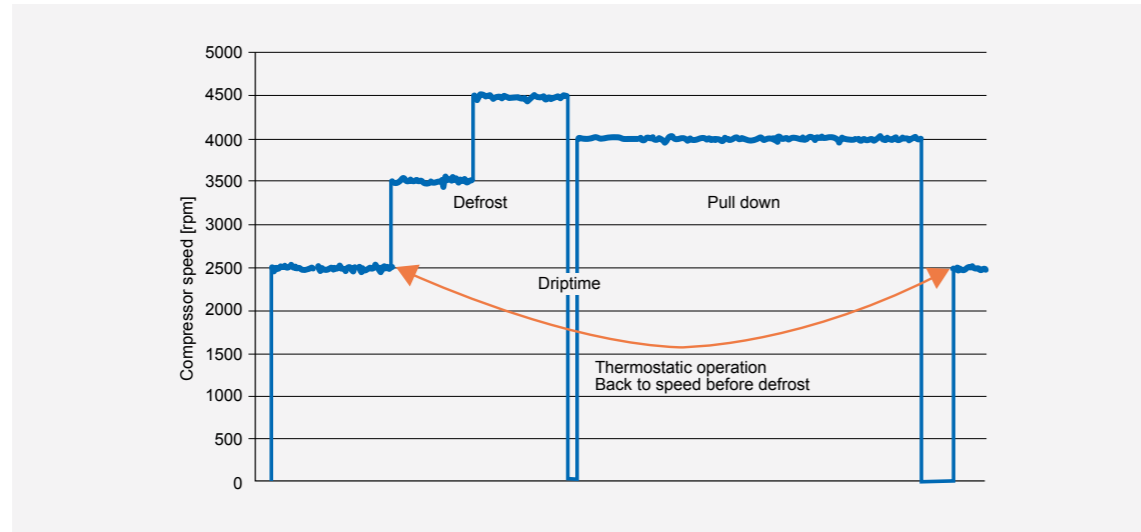

When variable-speed compressors are used in self-adapting capacity modes, defrosting may not work properly since the compressor speed cannot be controlled during defrost: The compressor lacks capacity for hot gas and the following pull-down.

To improve defrost when AEO is used, the Core Functions controller has an extra input that can be connected to the defrost relay output of the temperature controller.

- Hot-gas defrosting: When the defrost and AEO input are activated simultaneously, the Core Functions controller switches to a defined speed (defrost low speed). After a defined defrost low speed time, the compressor will increase to defrost high speed until the defrost is completed.
- The two-speed defrost is a new feature of all next generation controllers to avoid liquid refrigerant inside the compressor.
- Electrical defrosting: When only the defrost input is activated, the compressor will remain stopped, but the information is used to trigger pull-down after defrosting.
- After defrosting, the Core Functions controller will run the first cycle at high speed to ensure that the heat is removed as fast as possible.
- After the pull-down it reverts to the speed it had before defrost.



3

TECHNICAL DATA

3.1 Controller Data

	Electronic Unit	105N4120
Power supply	Nominal voltage	220-240V AC
	Minimum operating voltage	187V AC
	Minimum starting voltage	198V AC
	Maximum voltage	264 V AC
	Frequency	50-60 Hz
	Max power input	1000 W
	Power Factor Corrector	No
	Motor cable length	680±20 mm / 26.0-27.6 in.
Environment	IP class	IP31
	Humidity	30-90% rH
	Maximum operating temperature	50°C / 120°F
	Minimum operating temperature	0°C / 32°F
	Storage temperature	-30 to 70°C / -22°F to 158°F
Approvals/Safety	Compressor protection	Software protection + internal in compressor
	RoHs Conformity	IEC 62321
Speed-Control	Frequency input	5-12 V, max. 8 mA, 0-200 Hz
	AEO Thermostat input (Lsw)	198V-264 V AC, non-isolated
	AEO Defrost input (Def)	198V-264 V AC, non-isolated
	RX/TX interface (DWI)	5-12 V, max. 8 mA, 600 baud

3.2 Compressor Data

	NLV8.0CN / NLV10CN / NLV12.6CN	
Compressor	Application	LBP/MBP
	Evaporating temperature	°C -40 to 0 [-40 to 32] °F
	Voltage range/frequency	V/Hz 198-270/50/60
	Speed range	rpm 2000-4500

3.3 Capacity and Performance Data NLV8.0CN

Performance Data ASHRAE LBP [230 V, 50/60 Hz • fan cooling] @ -23.3°C (-10°F) evaporating temperature				
Speed	rpm	2000	3000	4500
Cooling capacity	W	272	418	558
	BTU/h	929	1426	1905
Power consumption	W	148	220	317
COP	W/W	1.84	1.90	1.76
EER	BTU/Wh	6.29	6.50	6.00
Test conditions		Condensing temp.: 54.4°C [130°F] Suction gas temp.: 32.2°C [90°F] Ambient temp.: 32.2°C [90°F] Liquid temp.: 32.2°C [90°F]		

Performance Data ASHRAE MBP [230 V, 50/60 Hz • fan cooling] @ -6.7°C (20°F) evaporating temperature				
Speed	rpm	2000	3000	4500
Cooling capacity	W	485	733	1049
	BTU/h	1657	2503	3581
Power consumption	W	206	310	450
COP	W/W	2.36	2.36	2.33
EER	BTU/Wh	8.06	8.07	7.96
Test conditions		Condensing temp.: 54.4°C [130°F] Suction gas temp.: 35°C [95°F] Ambient temp.: 32.2°C [90°F] Liquid temp.: 46.1°C [115°F]		

3.4 Capacity and Performance Data NLV10CN

Performance Data ASHRAE LBP [230 V, 50/60 Hz • fan cooling] @ -23.3°C (-10°F) evaporating temperature				
Speed	rpm	2000	3000	4500
Cooling capacity	W	340	522	749
	BTU/h	1162	1782	2559
Power consumption	W	186	276	417
COP	W/W	1.83	1.89	1.80
EER	BTU/Wh	6.25	6.46	6.13
Test conditions		Condensing temp.: 54.4°C [130°F] Suction gas temp.: 32.2°C [90°F] Ambient temp.: 32.2°C [90°F] Liquid temp.: 32.2°C [90°F]		

Performance Data ASHRAE MBP [230 V, 50/60 Hz • fan cooling] @ -6.7°C (20°F) evaporating temperature				
Speed	rpm	2000	3000	4500
Cooling capacity	W	606	916	1357
	BTU/h	2070	3128	4635
Power consumption	W	261	392	604
COP	W/W	2.32	2.34	2.25
EER	BTU/Wh	7.94	7.99	7.68
Test conditions		Condensing temp.: 54.4°C [130°F] Suction gas temp.: 35°C [95°F] Ambient temp.: 32.2°C [90°F] Liquid temp.: 46.1°C [115°F]		

3.5 Capacity and Performance Data NLV12.6CN

Performance Data ASHRAE LBP [230 V, 50/60 Hz • fan cooling] @ -23.3°C (-10°F) evaporating temperature				
Speed	rpm	2000	3000	4500
Cooling capacity	W	393	605	916
	BTU/h	1496	2305	3490
Power consumption	W	251	379	577
COP	W/W	1.75	1.78	1.77
EER	BTU/Wh	5.96	6.08	6.05
Test conditions		Condensing temp.: 54.4°C [130°F] Suction gas temp.: 32.2°C [90°F] Ambient temp.: 32.2°C [90°F] Liquid temp.: 32.2°C [90°F]		

Performance Data ASHRAE MBP [230 V, 50/60 Hz • fan cooling] @ -6.7°C (20°F) evaporating temperature				
Speed	rpm	2000	3000	4500
Cooling capacity	W	767	1190	1774
	BTU/h	2619	4064	6058
Power consumption	W	351	544	833
COP	W/W	2.19	2.19	2.13
EER	BTU/Wh	7.47	7.48	7.27
Test conditions		Condensing temp.: 54.4°C [130°F] Suction gas temp.: 35°C [95°F] Ambient temp.: 32.2°C [90°F] Liquid temp.: 46.1°C [115°F]		

4 DIMENSIONS

Compressor Dimensions		NLV8.0CN NLV10CN NLV12.6CN	
Height	mm (in.)	A	203
		B	197
Suction connector	location/I.D. mm (in.) angle material seal	C	8.2 15° Copper Rubber plug
		D	6.2 25° Copper Rubber plug
Discharge connector	location/I.D. mm (in.) angle material seal	E	6.2 21° Copper Rubber plug
		Connector tolerance	I.D. mm

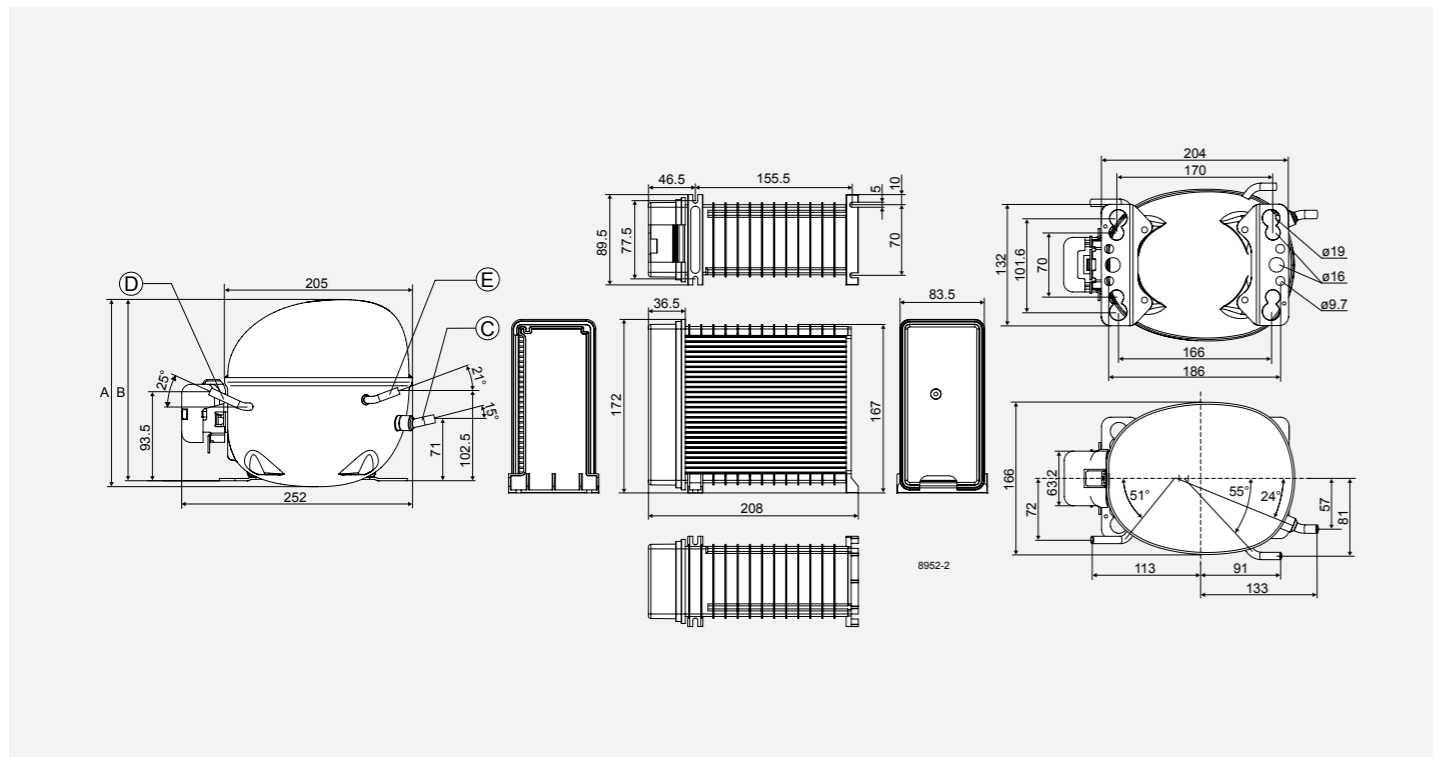

5 ORDERING

	Item	Code No.	Comment
Controller	Electronic controller (Core Functions), 220-240 V AC	105N4120	single unit
	NLV8.0CN compressor	105H7813	compressor w/ metric connectors
Compressor/Accessories	NLV10CN compressor	105H7013	compressor w/ metric connectors
	NLV12.6CN compressor	105H7363	compressor w/ metric connectors
	Cover for compressor	103N2008	
	Bolt joint for one compressor	118-1917	
	Bolt joint in quantities	118-1918	
Snap-on in quantities	118-1919		



SECOP GROUP: AROUND THE WORLD

SECOP

12

international
partners for
advanced
developments

33

laboratories
located in Germany,
Slovakia, China,
U.S.A., and Turkey

150+

R&D engineers
and technicians

400+

patents globally

50+

countries with
customer support



Secop is the expert for advanced hermetic compressor technologies and cooling solutions in commercial refrigeration. We develop high performance stationary and mobile cooling solutions for leading international commercial refrigeration manufacturers and are the first choice when it comes to leading hermetic compressors and electronic controls for refrigeration solutions for light commercial and DC-powered applications.

Secop was formerly known as Danfoss Compressors and is one of the founding fathers of modern compressor technology with years of experience that goes back to the beginning of the 1950s.

-  **Flensburg:** Sales and R&D
-  **Zlaté Moravce:** R&D, Logistics, and Manufacturing
-  **Turin:** Sales
-  **Tianjin:** Sales, R&D, Logistics, and Manufacturing
-  **Atlanta:** Sales and Logistics



**Stationary
Cooling**



**Mobile
Cooling**



**Medical
Cooling**



Secop GmbH · Lise-Meitner-Str. 29 · 24941 Flensburg, Germany · Tel: +49 461 4941 0 · www.secop.com

Secop accepts no responsibility for possible errors in catalogs, brochures, and other printed material. Secop reserves the right to alter its products without notice. This also applies to products already on order provided that such alterations can be made without subsequential changes being necessary to specifications already agreed. All trademarks in this material are the property of the respective companies. Secop and the Secop logotype are trademarks of Secop GmbH. All rights reserved.

Produced by Secop | May 2026

DES.S.300.R2.02