

EXTENDED CONTROLLERS FOR NLV-CN COMPRESSORS



105N4866 Multi Voltage · 100–240V | 50/60 Hz



Variable-Speed
Efficiency

Premium
Controllers

Commercial
Applications

TABLE OF CONTENTS

1. Introduction	4		
1.1. Applications	5		
1.2. Capabilities	5		
1.3. Operating Conditions	5		
1.4. Programming Interface	5		
1.5. Main Features	6		
2. Hardware Interface description	8		
2.1. In General	9		
2.2. Controller Connections	10		
2.3. Earthing the Compressor and Controller	11		
2.4. Mounting the Airflow	11		
2.5. Brazing: Warning!	12		
2.6. Checklist	12		
2.7. Electrical Ratings	13		
2.7.1. Temperature Sensors	14		
2.7.2. Analog and Digital I/Os	14		
2.7.3. Modbus Connection	15		
2.7.4. Power Connection	15		
2.7.5. Connecting Power Outputs	16		
3. User Interfaces	18		
3.1. Display	19		
4. Functions	22		
4.1. Application Control	23		
4.2. Modbus Addressing	24		
4.3. Temperature Acquisition	24		
4.4. Temperature Logger	27		
4.5. Reference for the Capacity Controller	29		
4.6. Compressor Capacity Control	30		
4.7. Emergency Cooling Function	34		
4.8. Evaporator Fan Control	35		
4.9. Condenser Fan Control	36		
4.10. Defrost Control	37		
4.10.1. Defrost Execution Details	38		
4.10.2. Defrost Scheduling	39		
4.11. Melt Function	40		
4.12. Case Cleaning Function	41		
4.13. Night Operation	42		
4.14. Blind Control	42		
4.15. Light Control	43		
4.16. Real Time Clock and Control Timer	44		
4.17. Alarm Handler	45		
4.17.1. Application Related Alarms	45		
4.17.2. Alarm Acknowledgement	47		
4.18. Safety Function	47		
4.19. Event Logging	47		
4.19.1. List of Possible Events	48		
4.20. Service Mode	49		
4.21. Rail Heater Control	51		
4.22. Gearbox	52		
4.23. Storing and Restoring to Factory Settings	56		
5. Analog and Digital Inputs and Outputs	58		
6. Configuring Relays	60		
7. Modbus	64		
7.1. Short Description of All Bus Parts	65		
7.2. Installation	66		
8. Technical Data	70		
8.1. Controller Connection	71		
8.1.1. Input Power	72		
8.1.2. Relays	72		
8.1.3. Modbus	72		
8.1.4. Temperature Sensors	73		
8.1.5. Analog and Digital I/Os	73		
8.2. Controller Data	74		
8.3. Compressor Data	75		
8.4. Capacity and Performance Data NLV8.0CN	76		
8.5. Capacity and Performance Data NLV10CN	76		
8.6. Capacity and Performance Data NLV12.6CN	77		
9. Dimensions	78		
10. Ordering	80		
10.1. Secop Orders	81		
10.2. Third-Party Orders	82		
NLV with Intelligent Multi Voltage Controller	84		
Secop Group: Around the World	86		

INTRODUCTION

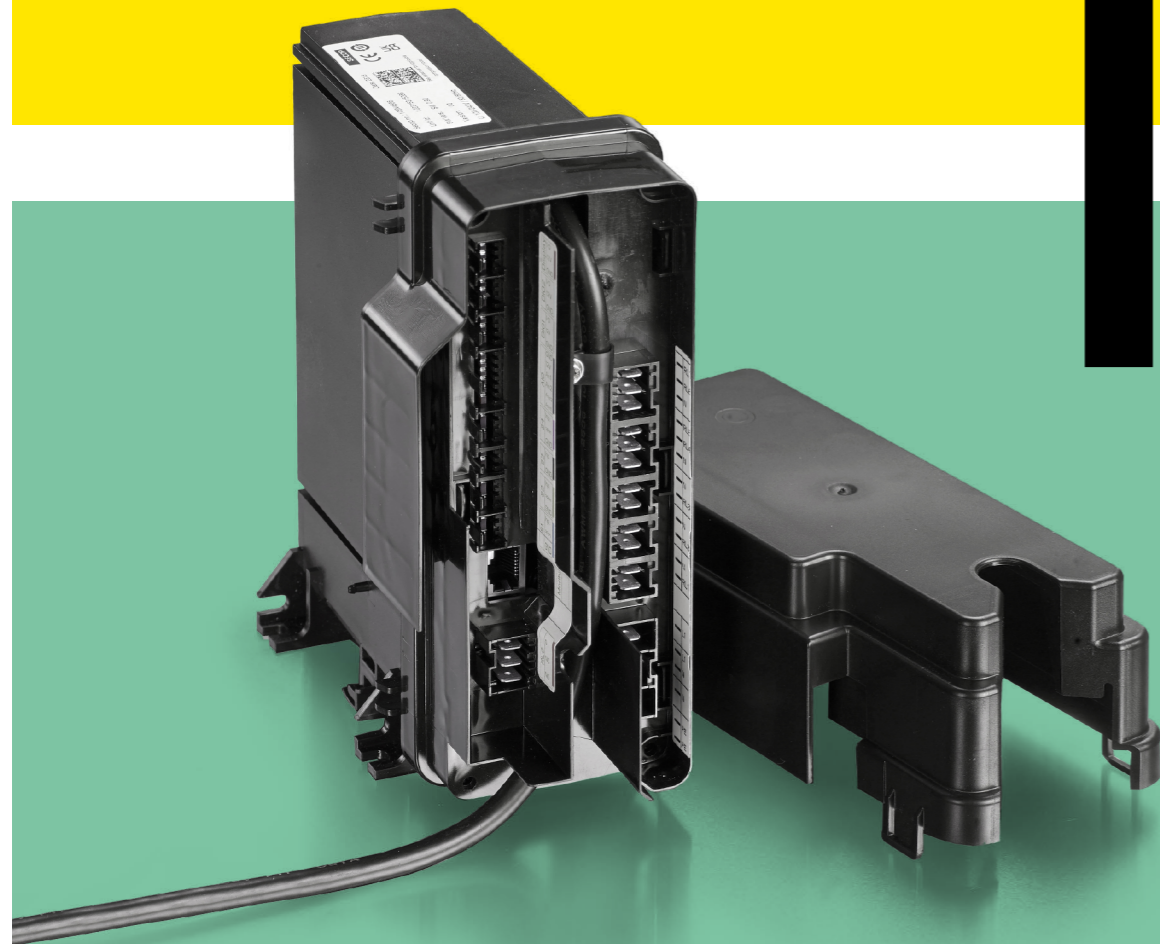

1.1. Applications

The 105N4866 controller regulates temperatures in refrigeration appliances, including supermarket refrigeration, freezer cabinet systems, and industrial kitchens.

The controller is a complete case controller with integrated inverter for variable speed compressors.

1.2. Capabilities

The controller is fully functional in every operation required for modern refrigeration control. The controller connects to a range of interfaces such as potentiometers, LED displays, PC software, and bus monitoring systems. The controller features an internal temperature and event logging system as well as general-purpose interface for broad and flexible application.

1.3. Operating Conditions

The compressor should be operated under the following conditions:

- Line voltage: Multi-Voltage (100–127V + 220–240V) operation 50/60 Hz
- Ambient temperature: 0 to 43°C

The controller should not be used in ambient air containing acids or alkalis. To ensure an optimal service life, the ambient temperature should be kept as low as possible (ambient temperature range for operation: 0 to 50°C compartment temperature, humidity 30–90%). The heat sink on the control units should not be covered, and no objects should be lent up against the enclosure.

The control system should not be exposed to dust and water above the IP43 requirements.

Ambient temperature range for storage: -20°C to 70°C

1.4. Programming Interface

The controller can be accessed via:

- The local display CRA 162, 172, and 200
- The Secop PC Service tool Tool4Cool® together with a RS485 gateway
- A custom interface – please contact Secop for further information regarding custom interfaces.

1.5. Main Features

- IP43 housing for maximum environmental protection
- 8 relay outputs for controlling fans, heaters, light, valves, and alarm output
- 4 temperature sensors with weighting for temperature control, defrosting, condenser sensing, and HACCP
- 4 digital inputs for door sensors, blind curtain, coordinated defrosting, light control, and main switch
- 2 analog inputs for pressure transducers
- 2 analog outputs for expansion valve control or light intensity
- 5 application sets of parameters for multi-function cabinets
- Motor control for variable speed brushless motors
- PID capacity control for precise cooling capacity control
- Management of minimum and maximum run times
- Alarm indication on the display, buzzer, via the Modbus interface, or via relay
- Display control (optional)
- Data logging system to save events in the memory of the control unit
- Hot gas defrost system with algorithms to reduce risk of liquid return to compressor
- Speed control evaporator and condenser fans
- Modbus communication for supermarket monitoring systems
- HACCP temperature reporting (not approved yet)
- Supported by Tool4Cool®
- Firmware upgrading through Modbus
- Power-factor corrector to comply with EU regulations
- Available for multi-voltage (100–127 V + 220–240 V) operation
- Backwards compatible connection to 105N46xx series controllers
- CCC-, UL-, VDE-approved with annex AA

The controller also features integrated monitoring of the operating conditions and takes corrective action to prevent any damage to the electronics, which

could potentially occur in the event of an overload.

The following monitoring functions ensure that operating conditions remain within the acceptable range:

- Temperature sensor on the printed circuit boards to monitor the temperature of the electronics in the enclosure
- Temperature sensor to monitor temperature in the motor inverter
- Monitoring for correct motor speed; motor speeds outside the permitted range can damage the valves and bearings
- Inadequate line voltage due to fluctuations in the line supply
- Locked rotor caused by excessive pressure
- Defrost valve and temperature sensor defects

Other advantages:

- Minimal start current required due to soft start of compressor
- Controlled restart
- Control of the pressure equalization time



HARDWARE INTERFACE DESCRIPTION

2



2.1 In General

- The connections are divided into different areas:
 - a "hot area" which is connected to line voltage;
 - a "cold area" which is separated from line voltage and safe to touch. This includes all sensors, display, and low-voltage signals; and a barrier in the housing, makes it possible to route low voltage cables and keep power cables separated.
- Signal lines must be separated from power lines
- Relay RL8 can both be used as a signal relay or power-relay. In case it is used for power, the cable must be routed together with the power-cables.
- Maximum cable length for signal and sensor cables is 3 meters. A cable length of more than 3 m could alter the EMI performance.
- All protective earth lines, PE, in the application must be connected to one star point.

The star-point is normally a screwed terminal on the chassis This prevents loop currents which could cause problems concerning the electronic components, communication lines and sensors.
- RCCBs (Residual Current Circuit Breakers) is recommended for safe installation.
- The controller must be protected by a circuit breaker, type C, 16-20A.
- L and N connection must be respected for polarized power-cords.
- Connecting the Modbus communication line between two devices when the cable is installed outside the building or between two buildings is not allowed. This prevents potential induction problems, in case of lightning.
- The display connection is used to connect the Secop display CRA 162, 172, and 200. Please refer to the hardware specifications for approved operating conditions.
- Installation may only be done by trained personal.
- Do not remove the cover of the inverter when the unit is powered.
- Disconnect from power and wait 30 seconds before accessing terminals.

2.2. Controller Connections

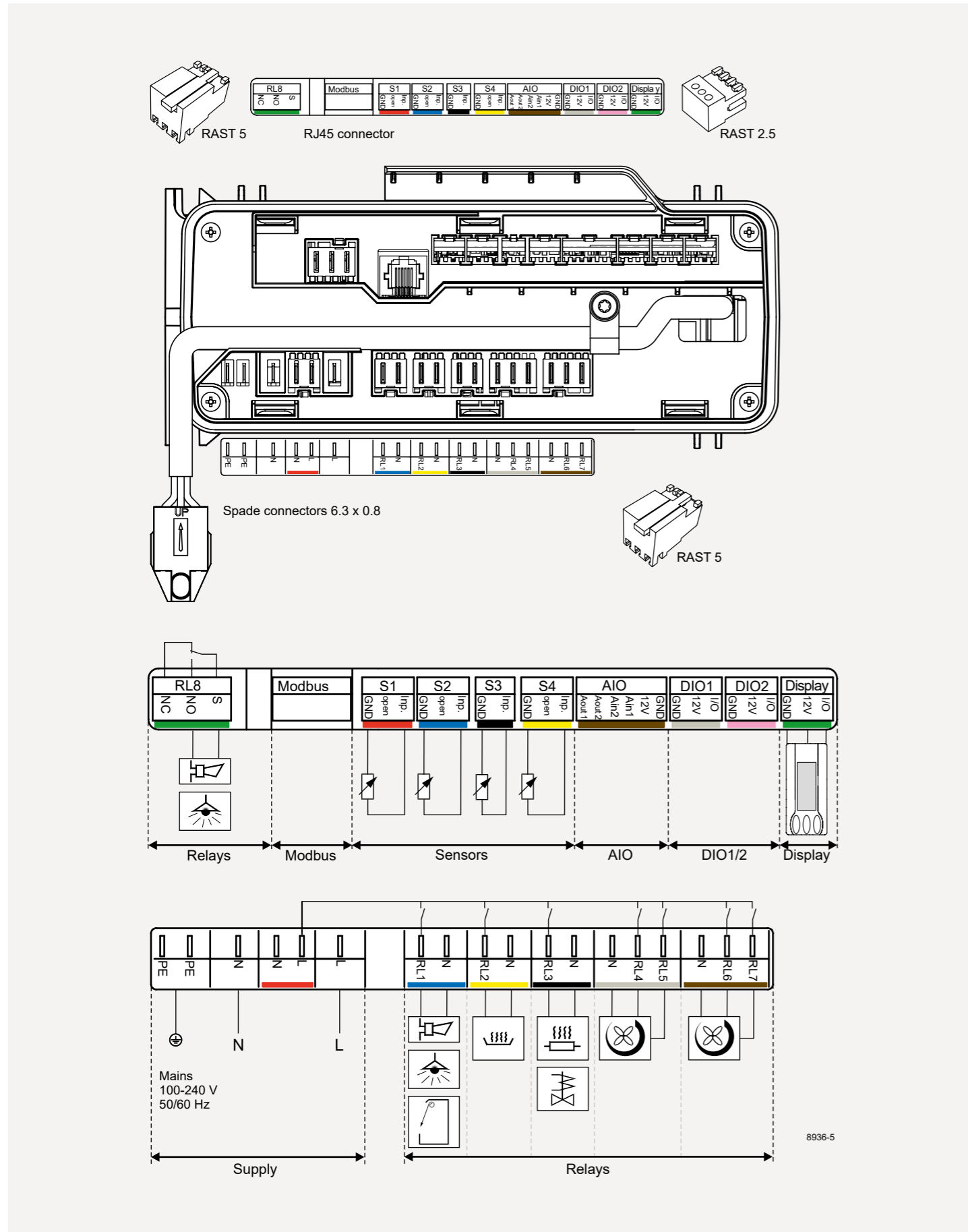

2.3. Earthing the Compressor and Controller

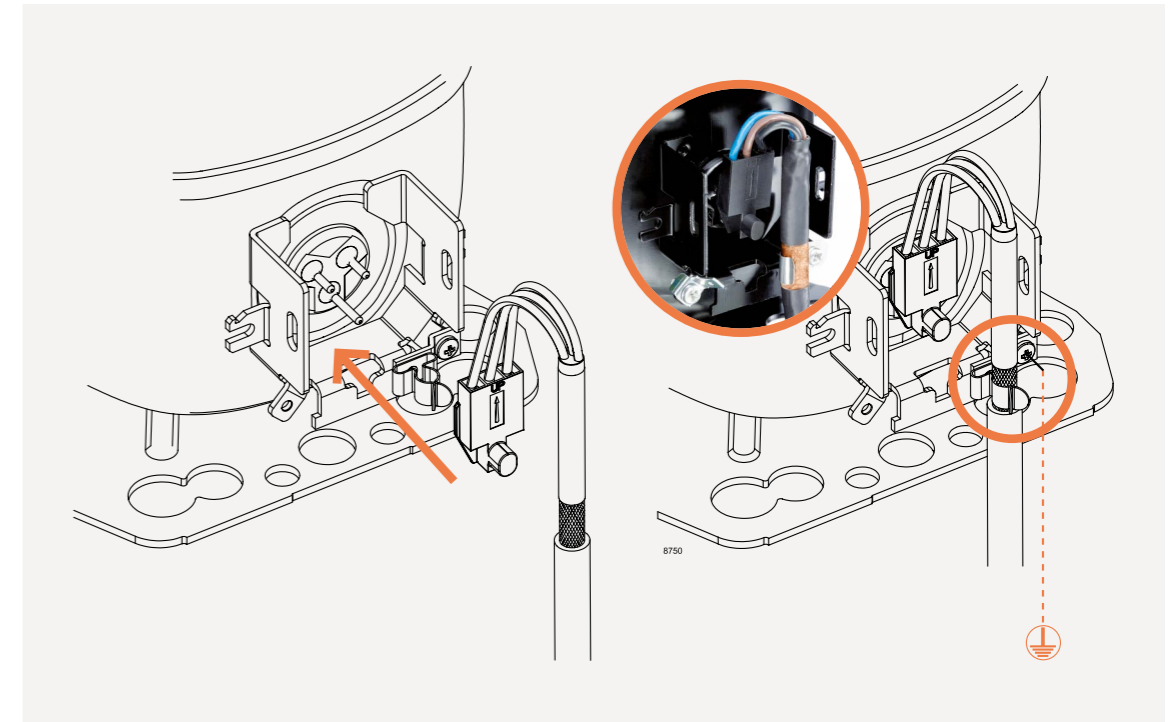

- For optimum EMC performance, the copper shield on the controller cable must be fastened properly in the clip at the compressor.
- Compressor and controller must be connected to PE (Protective Earth) to avoid risk of electrical hazard.
- All protective earth lines, PE, in the application must be collected to one star point. This prevents loop currents which could cause problems concerning the electronic components, communication lines, and sensors. The star point is normally a screwed terminal on the chassis.

2.4 Mounting: Airflow

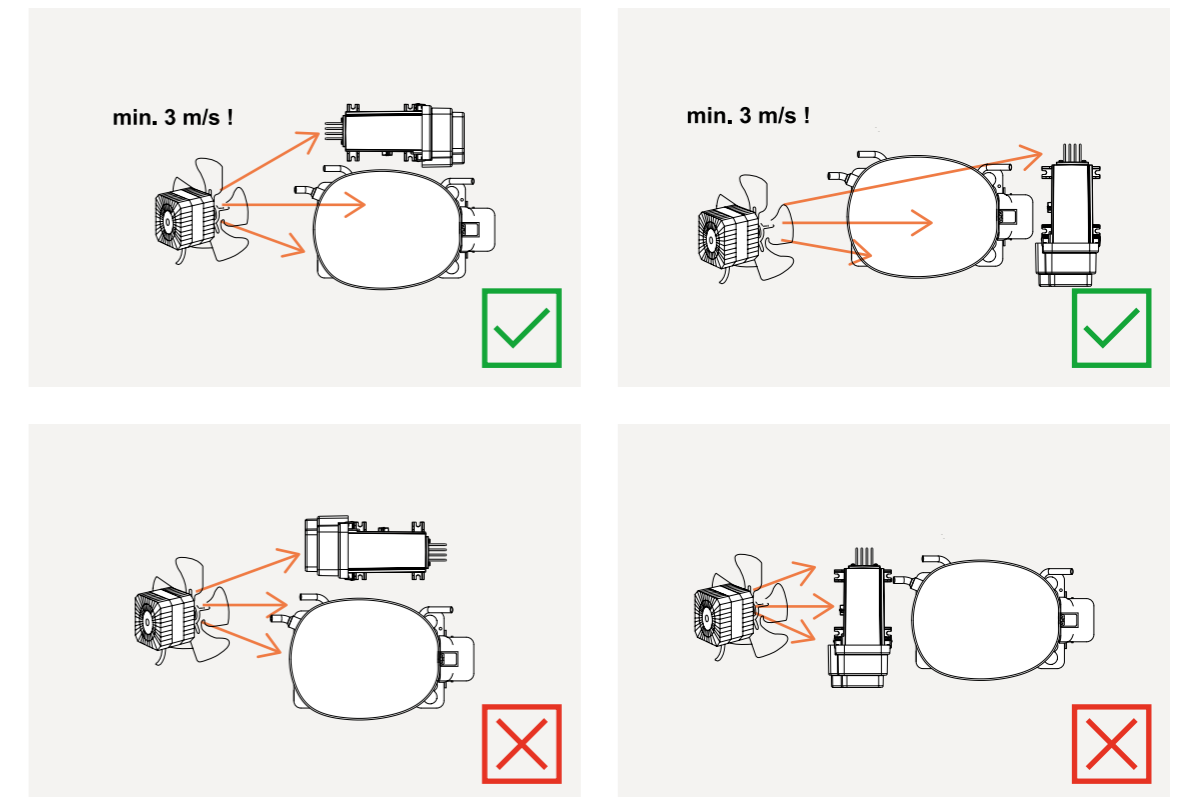

- Ensure proper airflow of 3 m/sec. at both compressor and heat sink of electronic unit.
- Ensure that the controller doesn't block for the airflow to the compressor.

2.5
Braiding:
Warning!



R290

To remove a compressor from a system, the tubes must be cut.

Never use a torch to remove brazed tubes.

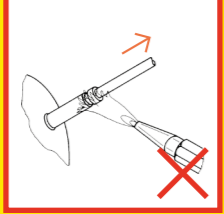
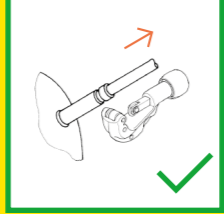
Brazing on Suction Connectors (Direct Intake)

representative image



**! max. 150°C/302°F !
at socket**

brazing solder: phosphor (LP7) or silver

Refer to Product Bulletin:
**Brazing on Suction Connectors
(Compressors with Direct Suction Intake)**

2.7.
Electrical Ratings

	Electronic unit	105N4866
Power supply	Nominal voltage	100-240 V AC
	Minimum operating voltage	80 V AC
	Minimum starting voltage	180 V AC
	Maximum voltage	270 V AC
	Frequency	50-60 Hz
	Max power input	1,000 W
	Power factor corrector	Yes, active, PF ≥ 0.95
	Motor cable length	680±20 mm / 26.0-27.6 in.

Environment	IP class	IP43
	Humidity	30-90% rH
	Maximum operating temperature	50°C / 120°F
	Minimum operating temperature	0°C / 32°F
	Storage temperature	-30 to 70°C / -22°F to 158°F

Approvals/Safety	Compressor protection	Software protection + internal in compressor
	Safety Approval	UL60335-2-34 with Annex AA EN60335-2-34 with Annex AA CB, CCC
	EMC conformity	According to 2014/35/EC
	RoHs conformity	2011/65/EU

Speed control	Frequency input	5-12 V, max. 8 mA, 0-200 Hz Galvanic isolated, short and reverse protected
	AEO thermostat input (Lsw)	80-264 VAC, non-isolated
	AEO defrost input (Def)	80-264 VAC, non-isolated
	RX/TX interface (DWI)	5-12 V, max. 8 mA, 600 baud galvanic isolated
	Single wire interface (SWI)	Modbus communication port, 9600 baud galvanic isolated

Relays	Max. individual load RL1-RL7	8A resistive, 30,000 cycles
	Max. total load RL1-RL7	16A resistive
	Max. load RL8	3A resistive

2.6.
Checklist

1 Secop 105N4866 controller

! Service product key for controller:
- On request -

2 NTC temperature sensor
(color-coded)

3 Display
CRA 200, 172
or 162 cable
must be ordered
separately)

4 RS485 to USB gateway
→ Gateway
→ USB power supply
→ DSUB-9/RJ45 adaptor
→ RJ45 Ethernet patch cable

5 Tool4Cool®
LabEdition
software

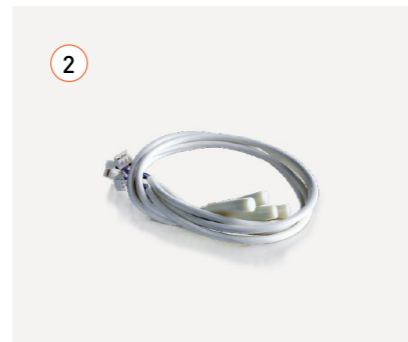
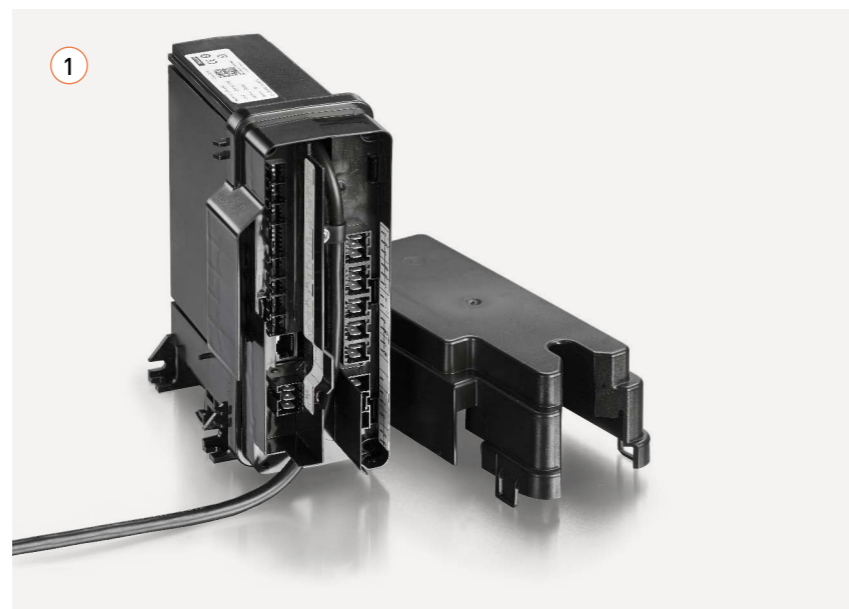

5



Software Download

Tool4Cool® Flexible Control Settings
www.secop.com/tool4cool

2.7.1. Temperature Sensors

The controller provides the option to connect up to 4 temperature sensors.

The general sensor setting is:

- Sensor S1 and S2 are used to measure the cabinet temperature.
- Sensor S3 is used for product temperature (HACCP) or condenser fan control.
- Sensor S4 is used for controlling defrost.

Name	Pin	Type	Specification
S1	1	GND	Measurement range: -55 to 85°C
	2	Not connected	
	3	Analog input	
S2	1	GND	Sensor characteristics: Nominal resistance at 0°C: 16.3kΩ Nominal resistance at 25°C: 5.0kΩ
	2	Not connected	
	3	Analogue input	
S3	1	GND	Nominal resistance tolerance: ±2% B value: 3980 K B value condition: B25/100 B value tolerance: ±1.5%
	2	Analogue input	
S4	1	GND	
	2	Not connected	
	3	Analog input	

2.7.2. Analog and Digital I/Os

The controller provides 2 analog I/Os and 4 digital I/Os.

The digital I/Os can be used to connect the auxiliary contact device, door sensor, buzzer, and light switch. The controlling function can be selected by the software parameters.

The analog I/Os can be used for customized use such as pressure transducers, light control, and fan speed control. The analog inputs can be configured as digital inputs too.

Name	Pin	Type	Specification
DI01	1	GND	10–12 V DC Digital output: “open collector” Internal pull-up resistor to V supply: 10 kΩ Signal voltage range (low/high): 0/5–12 Vpp
	2	V supply	
	3	Digital I/O	
DI02	1	GND	10–12 V DC Digital output “open collector” Internal pull-up resistor to V supply 10 kΩ Signal voltage range (low/high): 0/5–12 Vpp
	2	V supply	
	3	Digital I/O	
Display (DI03)	1	GND	10-12V DC Internal pull-up resistor to V supply 10 kΩ Signal voltage range: 5–12 Vpp Max current sourcing: 20 mA Half-duplex single wire, baud rate: 1200–9600
	2	V supply	
	3	Single wire interface signal (SWI)	
AI01	1	GND	10–12 V DC
	2	Vsupply	
	3	Analog/digital input	Analog signal range: 0–5 V Input impedance >10 kΩ
	4	Analog/digital input	
	5	Analog output	Currently not enabled
	6	Analog output	

2.7.3. Modbus Connection

Name	Pin	Signal	Type	Specification
MODBUS RTU	4	D1		Standard: IEA485 Maximum nodes: With RC termination: 100 With resistor termination: up to 32 Cable max. length: 1000 m Maximum stub No. and length: 30/1 m Termination: Resistor 150 Ω (30 nodes) Recommended RC series: 120 Ω, 1nF Installation must be in accordance to “standard modbus.org” with RJ45 plugs and CAT5
	5	D0		
	8	Common		

2.7.4. Power Connection

The controller operates in two voltage bands.

- At startup, the controller will detect the connected voltage and set the minimum and maximum limits for the detected band accordingly.
- If the controller operates in the low voltage band and detect a voltage higher than 155 VAC but lower than 160 VAC, it will close and disconnect all outputs.
- If the voltage is above 180 VAC it will switch to the high band after a short interruption.
- The disconnection of the relays and compressor is to protect both compressor and auxiliary devices such as fans and valves.

System Stop	No Operation	Nominal 100–127 VAC			No Operation	Nominal 220–240 VAC			No Operation
<50 V	<80 V	80–90 V	90–150 V	150–155 V	155–160 V	160–180 V	180–270 V	270–280 V	>280 V

- The dark green area shows “Continuous Run”
 - Within this range, the compressor can run, start, and stop without any restrictions.
- The light green range shows where the compressor will continue to run, yet restarts are not possible
- As soon as you enter the “No Operation” area, the controller will show a voltage failure. It will stop and only start again within “Continuous Run” area (dark green)
- In the red area (below 50 V), the controller will switch off and can no longer send any alarm, etc.

Power connection can be done by:

- 2-pole Rast5 connector
- Standard 6.3 × 8 mm faston connectors



Name	Type	Coding of external connector
Protective earth (PE)	2 pcs. tab 6.3 × 0.8 mm	No coding
Power supply	2 pole RAST 5 or 2 pcs. tab 6.3 × 0.8 mm (Black means pin is present)	

Note:

Maximum current rating for the chosen connector system and proper wiring must be considered in the application.

**2.7.5.
Connection of
Power Outputs**

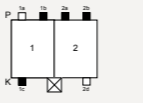
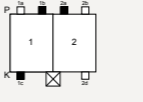
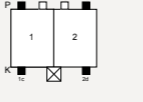
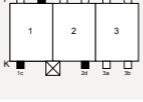
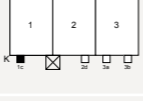
- All connector outputs on the power board are pre-wired with neutral and live switched over the relay.
- The connector outputs are mechanically coded to prevent wiring errors in production and service.
- Connectors 1 to 4 are compatible with 105N46xx series controllers.
- The coding scheme shows the position of keying and locking latches. Black means the key is present.

Name	Connector	Pin	Type	Connector
RL 1	1	1	Live switched, N.O.	
		2	Neutral	
RL 2	2	1	Live switched, N.O.	
		2	Neutral	
RL 3	3	1	Live switched, N.O.	
		2	Neutral	
RL 4 RL 5	4	1	RL4 output, live switched, N.O.	
		2	RL5 output, live switched, N.O.	
		3	Neutral	
RL 6 RL 7	5	1	RL6 output, live switched, N.O.	
		2	RL7 output, live switched, N.O.	
		3	Neutral	
RL 8	6	1	N.C.	
		2	N.O.	
		3	Base pin	

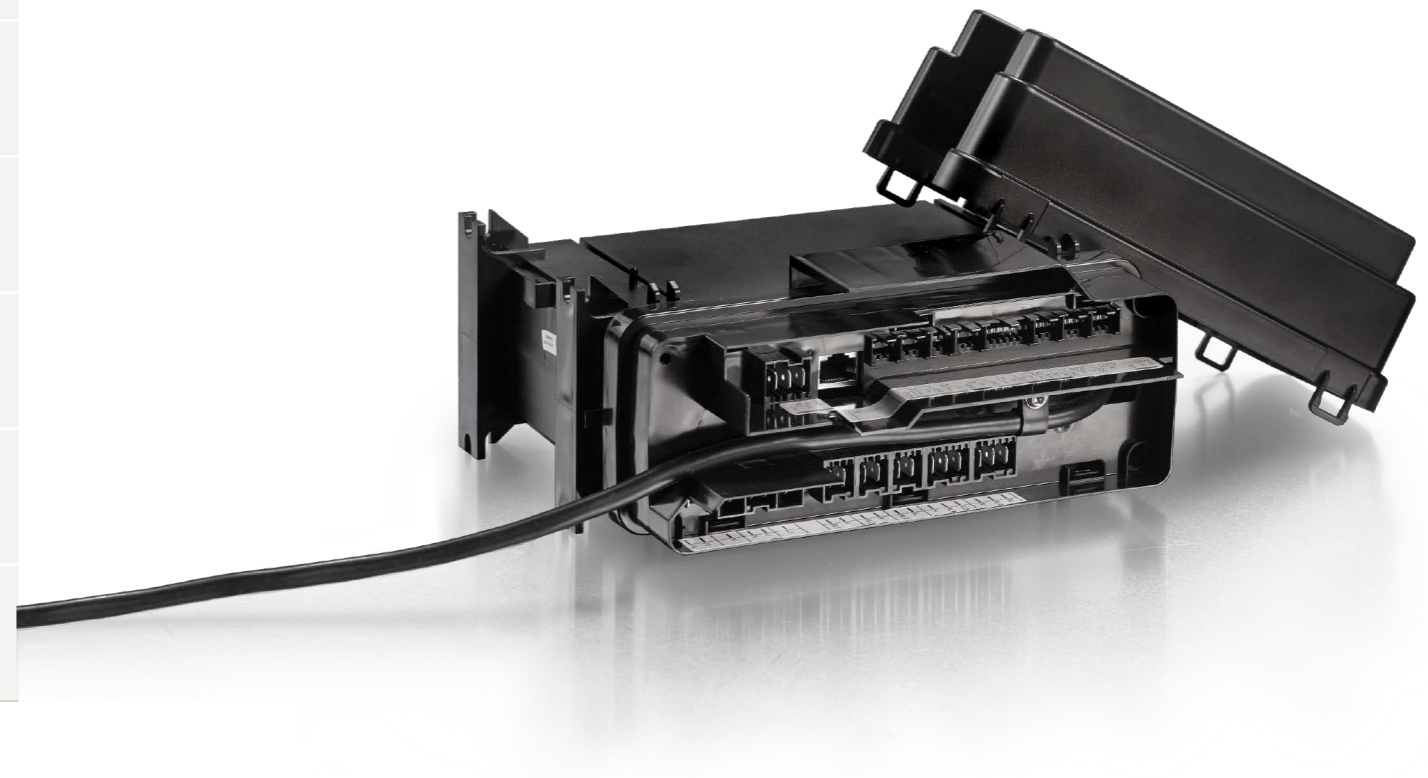

- Max. load for individual relays: RL1–RL7:
 - 8 A res., 30,000 cycles
 - 2(2)A, 100,000 cycles
 - 12 RLA, 2 FLA, 100,000 cycles
- Max. total load for RL1–RL7 depends on compressor status:
 - max when compressor is stopped: 16A (electrical defrost)
 - Max when compressor is running: 6A
- Max load: RL8: 2A res, 100.000 cycles

USER INTERFACES

The different parameters of the controller can be accessed via the local display or via the Modbus. In this section, only the local display interface will be described.

3



3.1. Display

The display performs the following functions:

- Daily operation of the cooling appliance
- Readout of measurements and status of the refrigeration system, actual temperature, alarms
- Defrost activation
- Start and stop of appliance
- Setting of parameters
- Reset of alarms

The display has the following layout:

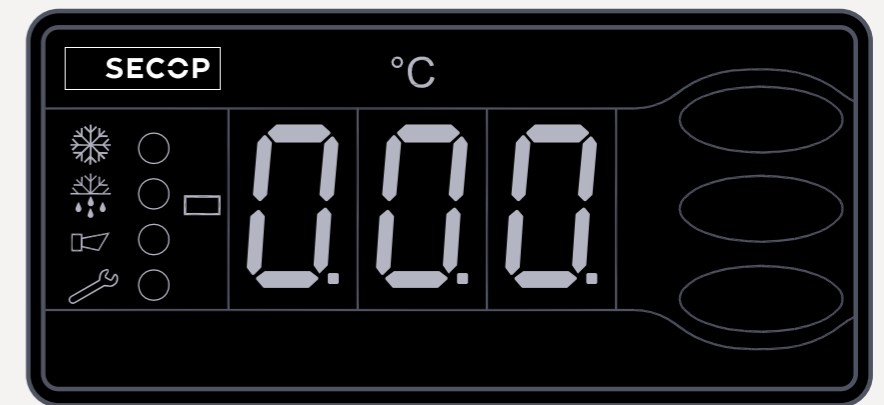

Display CR-172

Left are 4 status LEDs with the following functions (from top down):

- 1) LED 1: Compressor Run Status (unless defrost)
- 2) LED 2: Defrost, Melt, Case Cleaning
- 3) LED 3: Alarm
- 4) LED 4: Editing Mode

→ One minus sign

→ 3 seven segment LEDs (1,2,3) with one decimal dot between LED segment 2 and 3

→ 3 push buttons with the following names (from top down):

top button, middle button, bottom button

Menu structure for the display:

The maneuvering through the local display menu structure is based on different activations of the buttons on the right side of the front.

There are 3 different ways of activating the buttons:

- single short activation
- single long activation
- triple short activation

Event	Action
Top button short	Application change over if more than one application is enabled. Repeated activation toggles between the enabled applications.
Top button triple	Change Modbus address (only when stopped)
Top button long	No action
Middle button short	Start/Stop defrost depending on d90 and d61
Middle button triple	Change to Code/-→ (Edit Set point)
Middle button long	No action
Bottom button short	Acknowledge alarm/Inspect alarm list
Bottom button triple	No action
Bottom button long	Stopped / Running

By entering the correct access code, it's also possible to access the service level of the controller. In addition to the numeric display, there are 4 additional LED's which show the status of Alarm, Defrosting, Service, and Cooling.

To access the different parameters of the controller for the local display interface, there are three different access levels.

Each level can be protected with an individual access code, defined by the manufacturer of the cooling appliance. If a level is protected with an access code, this code must be entered first. If the controller is accessed via both the CRA 162/172/200 and the Modbus at the same time, the latest modified value for a setting will be stored as the final.

The access code can be adapted in the Service Mode structure in Tool4Cool®

Parameter Function	Code	Min.	Max.	Default Setting
Access code Daily User	o05	0	999	0
Access code Ice	o06	0	999	0
Access code Bottle	o07	0	999	0
Access code OEM	o08	0	999	0



FUNCTIONS



4

4.1. Application Control

The controller is designed for multi-application cabinets. For instance, universal cabinets where the user can change the unit from freezer to cooler mode just by pressing a button or by changing a single parameter.

Up to 5 applications can be defined. Each application contains basically any setting for a specific application, such as freezer, cooler, dairy products, meat, or night operation. Applications can be changed via the local display, Modbus, external switch, or internal timer.

The following parameters can be set:

- Temperature settings: set points, offsets, time constants, sensor weighting
- Alarms: Which alarms should be reported and were, limits, delay of alarms
- Defrost control, defrost scheduling
- Relay usage
- Sensors, time constants, offsets
- User interface: resolution of temperature, temperature unit, definition of buttons
- Peripherals, fans, light, heaters

How to manage applications:

1. Enable the number of applications you need. If only 2 are needed, then enable 2 and disable the remaining
2. Name the applications to get a better overview in Tool4Cool®
3. Select the application to edit the parameters
4. Go through the settings one by one
5. When finished, switch to the next application and repeat [4] until all (enabled) applications have been set

Parameter Function	Code	Min.	Max.	Default Setting
Application selection via MMI and remote				
0: Application 1				
1: Application 2	P10	0	4	0
2: Application 3				
3: Application 4				
4: Application 5				
Application 1 selectable	P01	0	1	1
Application 2 selectable	P02	0	1	0
Application 3 selectable	P03	0	1	0
Application 4 selectable	P04	0	1	0
Application 5 selectable	P05	0	1	0
Selected application (Read only)				
0: Application 1				
1: Application 2	P20	0	4	RO
2: Application 3				
Application selection via DIO	P27	0	5	0
Application 1 nighttime	P21	0 (none)	5	0
Application 2 nighttime	P22	0 (none)	5	0
Application 3 nighttime	P23	0 (none)	5	0
Application 4 nighttime	P24	0 (none)	5	0
Application 5 nighttime	P25	0 (none)	5	0
Application active timer	P28	0	5	0

4.2. Modbus Addressing

The controller can be mounted in a Modbus network of up to 99 controllers. To recognize the different controllers on the network, each controller must have its own, unique address.

Functional description:

The Modbus address can be set either via the Tool4Cool® service tool or the local display. If the controller has a password, this must be entered first.

The address range can be set in the range from 1 to 99. Parameter "Modbus address" (o03).

Parameter Function	Code	Min.	Max.	Default Setting
Modbus address	o03	0	99	1
Modbus baud rate 1 = 9600 2 = 19200	o04	1	2	2

Restrictions:

If the Modbus address is modified via the Tool4Cool®, the user must ensure that the new address is within the setting range of the Tool4Cool®, otherwise communication to the controller will be lost, until the correct address range has been selected on Tool4Cool®, and the network has been scanned again.

4.3. Temperature Acquisition

The temperature acquisition system handles all the temperature measuring related issues, such as sensor selection, weighting of sensors, and sensor error detection.

The NLV controller has 4 sensor inputs. The S1, S2, S3, and S4 sensors are compatible with the 5K NTC sensors. All sensors are NTC sensors. Please refer to the chapter Temperature Sensors.

Sensor configuration:

The sensors are configured by software parameters in the function where it is used.

For instance, the defrost sensor is configured in the defrost control menu. Temperature control sensors are configured for several functions, such as capacity control, alarms, display, Modbus reading, or temperature logging.

Generally, the S1 and S2 sensors are used to measure the cabinet temperature, S4 for controlling defrost, and S3 for product temperature or condenser fan control.

Offset adjustment of temperature measurements:

To compensate for measuring errors or wrong placement of the sensor, all sensors include an offset adjustment. With the parameter "Fx temperature offset" (r09), (r10), (r55), and (r57) it is possible to adjust the respective temperature measurements from -10 to 10 K.

Filtering of temperature measurements:

Furthermore all temperature measurements can be filtered with the parameter "Filter constant for Txx" (o90 to o96), which can be used for very unstable or fluctuating temperatures.

→ 0: no damping, (fastest updating of the read out)

→ 10: 0.01 K/sec (slowest updating of the read out)

Parameter Function	Code	Multiple Apps	Min.	Max.	Default Setting	Unit
S1 temperature offset	r10	x	-10	10	0	°K
S2 temperature offset	r09	x	-10	10	0	°K
S4 temperature offset	r57	x	-10	10	0	°K
S3 temperature offset	r55	x	-10	10	0	°K
S1/S2 temperature offset	r04	x	-10	10	0	°K
Filter constant for T _{act}	o90	x	0 (none)	0.10	0.01	K/sec.
Filter constant for T _{alarm}	o91	x	0 (none)	0.10	0.01	K/sec.
Filter constant for S1/S2	o92	x	0 (none)	0.10	0.01	K/sec.
Filter constant for S4	o94	x	0 (none)	0.10	0.01	K/sec.
Filter constant for S3	o96	x	0 (none)	0.10	0.01	K/sec.

Weighting of sensors:

In some cases, it might be necessary to use 2 sensors at different locations, to achieve the correct temperature measurement. For instance, top-bottom, left-right, or evaporator inlet – outlet.

Different weighting (balancing) can be set for sensor S1 and S2 at day and night, for alarms, temperature control, and display.

Weighting is done by setting a parameter between 0 to 100%, depending on how much influence the sensors should have on the temperature measurement.

If the parameter is set to 0%, only S1 is used, if set to 100%, only S2 is used.

If 50%, both S1 and S2 will have the same influence.

Example: S1 is -22°C and S2 is -18°C. If weighting (w) set to 25%, the resulting temperature is -21°C.

$$S_w = S_1 * (1 - w) + S_2 * w$$

Parameter Function	Code	Multiple Apps	Min.	Max.	Default Setting	Unit
Definition and weighting, of sensors S1 and S2 when daytime mode is present (100%=S2, 0%=S1)	r15	x	0	100	100	%
Definition and weighting, of sensors S1 and S2 when nighttime mode is present (100%=S2, 0%=S1)	r61	x	0	100	100	%
Definition and weighting, of sensors S1 and S2 T _{alarm} (100%=S2, 0%=S1)	A36	x	0	100	100	%
Definition and weighting, of sensors S1 and S2 for S1/S2 (100%=S2, 0%=S1)	o17	x	0	100	100	%

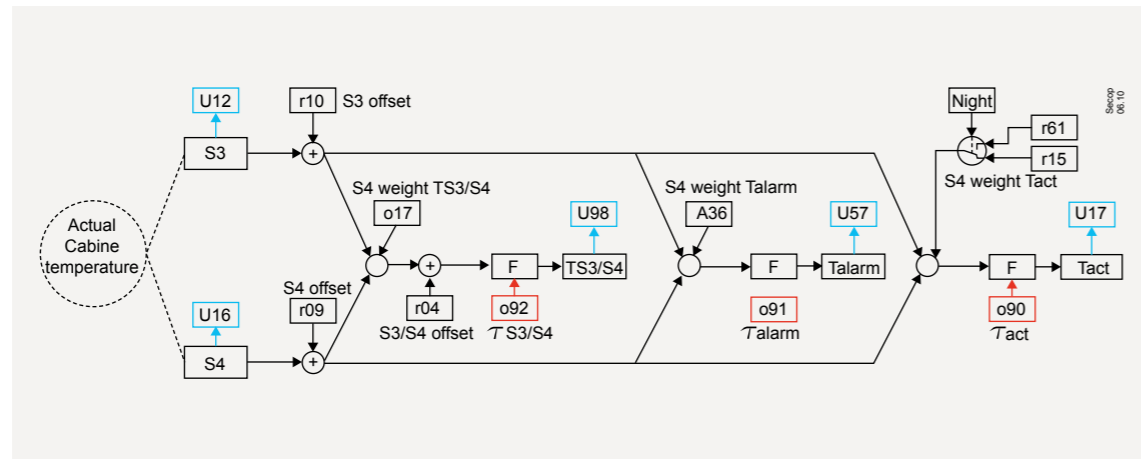

Parameter Function	Code	Multiple Apps	Min.	Max.	Default Setting	Unit
S1 temperature	U12		-300	+300	RO	°C
S2 temperature	U16		-300	+300	RO	°C
S3 temperature	U76		-300	+300	RO	°C
S4 temperature	U09		-300	+300	RO	°C
S1/S2 temperature	U98		-300	+300	RO	°C
T _{act} temperature	U17		-300	+300	RO	°C
T _{haccp} temperature	U99		-300	+300	RO	°C
T _{disp} temperature (displayed on MMI)	U56		-50.0 (see r06)	+300	RO	°C/°F
T _{alarm} temperature	U57		-300	+300	RO	°C

Read out on the display:

It's possible to select between a variety of different parameters to be shown on the display, "Display temperature" (099). With "Display minimum limit temperature" (r06) the minimum read out can be limited downwards. Furthermore, it's possible to select, whether the temperature read out on the display must be in °C or °F. The parameter "Temperature unit" (r05) is set to °C as default.

Restrictions:

All sensor inputs include a detection of open or shorted sensors. A sensor alarm will only be reported and sent out if the sensor is being used by a function. If a sensor fails the sensor readout will be set to -300 °C for an open circuit and +300 °C for a shorted sensor. If the sensors S1/S2 are used in a weighted combination and one of the sensors fails, the sensor with no failure will be used and weighting is disabled. An alarm will be sent out for the defective sensor.

Dependencies:

The step resolution for the display will be defined by the parameter "Display temperature step resolution" (o15). Please refer to chapter Display.

Parameter Function	Code	Multiple Apps	Min.	Max.	Default Setting	Unit
Temperature unit (°C = 0/°F = 1)	r05		0	1	0	°C/°F
Display minimum limit temperature (-300 if used sensor value is faulty)	r06		-50 (-300)	20	-50	°C
Display temperature step resolution 1 = 0.1°K 2 = 0.5°K 3 = 1.0°K	o15	x	1 (0.1)	3 (1.0)	2 (0.5)	- (°K)
Display temperature 0 = S1/S2 (U98) 1 = T _{alarm} (U57) 2 = T _{act} (U17, default) 3 = T _{haccp} (U99) 4 = S1 (U12) 5 = S3 (U76) 6 = S2 (U16) 7 = S4 (U09)	o99	x	0	7	2	-
Selection of sensor for the HACCP function. 0 = None 1 = None 2 = S2/S1 3 = T _{alarm} 4 = T _{act} 5 = S4 6 = S3 Note: If "h11 = 0": T _{haccp} (U99) = 300.00°C	h11	x	0	6	0	

4.4. Temperature Logger

The NLV controller has an internal temperature logger that can log a predefined temperature directly into the memory of the NLV controller. It is possible to attach an alarm to the logger, which will indicate a warning when the upper or lower alarm limits are exceeded, and when the alarm delay timer has elapsed.

Functional description:

Using the parameter "Selection of sensor for the logger function" (h11), it is possible to select a temperature sensor or an internal temperature calculation for the temperature logger. If no sensor is selected, the logger will not begin. Logging speed is determined by "Log interval" (h01). The number of logs is limited to 1,000. This means that the duration of the logging period depends on the number of logs. For logging duration, please see the following table.

Logging Interval	Maximum log duration in hours	Maximum log duration in days
15 minutes	250	10 days
30 minutes	500	20 days
60 minutes	1000	40 days

As soon as the logger is full, the oldest logs will be deleted and overwritten with a new log.

To limit at a certain number of logs, it is possible to set up thresholds for the logging range.

Logging of temperatures outside a predefined range:

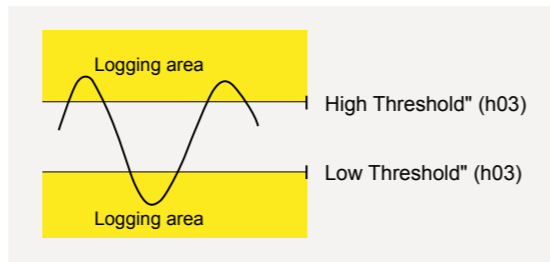

As soon as the logger is full, the oldest logs will be deleted and overwritten with a new log.

To limit at a certain number of logs, it is possible to set up thresholds for the logging range.

Logging of temperatures outside a predefined range:

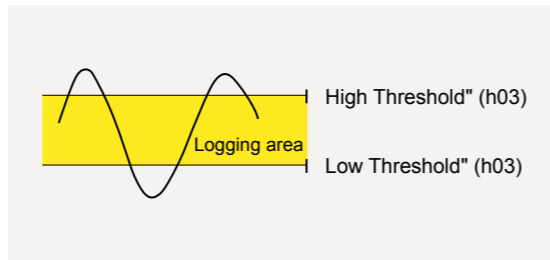

If the "Low Threshold" (h03) is set higher than the "High Threshold" (h02), only temperatures inside these limits will be logged.

If the "Low Threshold for logging" and "High Threshold for logging" are set equal, no logging will be performed.

Furthermore, the temperature logger contains a separate high alarm function (h12) with adjustable alarm delay (h13).

Restrictions:

The maximum number of logs is limited to 1,000.

In the event of a sensor error on the selected temperature probe, there will be no logging. Instead, a sensor error alarm will be generated.

Parameter Function	Code	Multiple Apps	Min.	Max.	Default Setting	Unit
Log interval	h01	x	15	240	30	Min.
High threshold for logging	h02	x	-50°C or -58°F	50°C or 122°F	-50	°C/°F
Low threshold for logging	h03	x	-50°C or -58°F	50°C or 122°F	50	°C/°F
Selection of sensor for the logger function 0 = No logging function defined 1 = S1/S2 temperature 2 = T _{alarm} temperature 3 = T _{act} temperature 4 = S4 temperature 5 = S3 temperature	h11	x	0(0.1)	3 (1.0)	1	-
Alarm limit for the logger function	h12	x	-50°C or -58°F	7	60	°C/°F
Time delay for the alarm	h13	x	1	6	60	Min.

4.5. Reference for the Capacity Controller

The purpose of the reference function is to generate a reference for the compressor capacity controller and to create the limits for the temperature setting range during the day and nighttime. Based on the deviation between the actual temperature T_{act}, compared to the temperature reference T_{ref}, the capacity controller will increase or decrease the requested compressor capacity. The bigger the deviation, the faster the requested compressor capacity will be adapted.

Measurement and calculation of actual cabinet temperature T_{act}:

The cabinet temperature can be measured with either S1, S2 or in special applications as a weighted combination of both. In the event of incorrect temperature measurements due to wrong placement of the sensors, both temperature inputs include an offset adjustment possibility. "S1 temperature offset" (r10) and "S2 temperature offset" (r09).

For the cabinet temperature measurement, with S1 and S2, a weighting of these 2 sensors is implemented. Please refer to the chapter Temperature Acquisition.

Calculation of T_{ref}

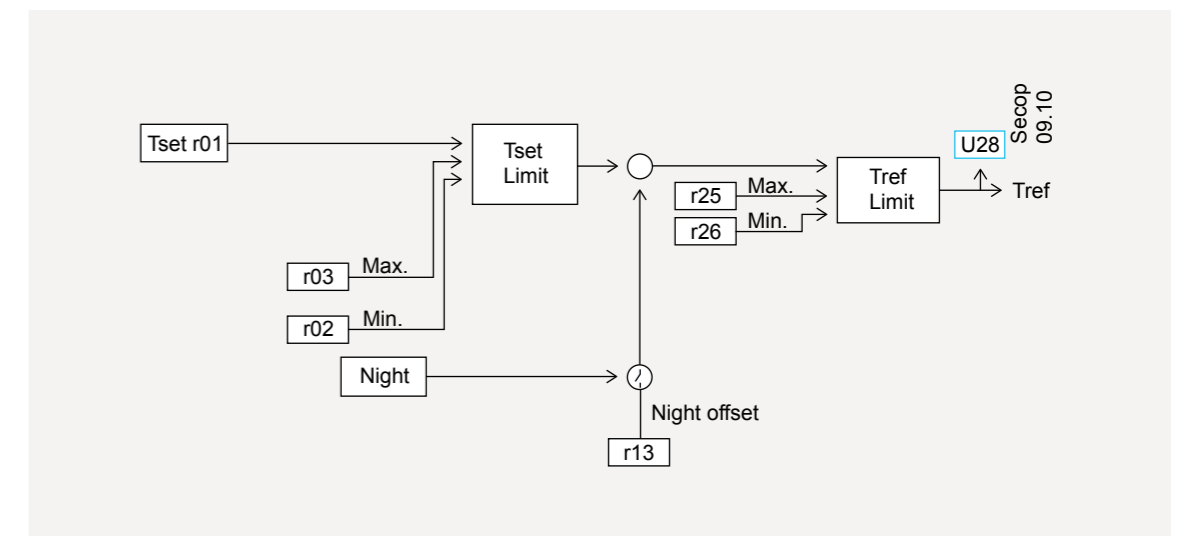

Parameter Function	Code	Multiple Apps	Min.	Max.	Default Setting	Unit
T _{set}	r01	x	-49	Qqy	-20	°C
Max. limitation of reference T _{set}	r02	x	-49	50	-15	°C
Min. limitation of reference T _{set}	r03	x	-50	49	-27	°C
Max. limitation of reference T _{ref}	r25	x	-49	50	-15	°C
Min. limitation of reference T _{ref}	r26	x	-50	49	-27	°C
T _{set} nighttime temperature offset	r13	x	-10	10	0	°K
Switch between sensor S2 and S4 Note: All parameter names are listed for value 0 (S2)	o18	x	0 = S2	1 = S4	1	-

The temperature reference T_{ref} for calculating the reference for the PID controller is calculated as follows:
T_{ref} = T_{set} + "Nighttime temperature offset" (r13)

The setting range of T_{set} can be limited with the 2 parameters "T_{set} max" (r02) and "T_{set} min" (r03).

To avoid a temperature reference too high or too low, the allowed temperature reference band is limited with the following 2 set points: "T_{ref} min" (r25) and "T_{ref} max" (r26).

4.6. Compressor Capacity Control

The purpose of this function is to calculate the requested compressor capacity that is needed to cool down or maintain the correct cabinet temperature during normal temperature control.

During the pull up/down of the cabinet, after the initial start or after a defrosting sequence, the capacity controller will be overruled by predefined capacity requests.

Functional description:

The reference "T_{ref}" for the controller is given by the reference function, based upon either the temperature sensor S1, S2, or a mix of both.

The actual requested compressor capacity is determined based on a PI controller that compares the actual temperature with the reference temperature. The greater the deviation in temperature, the faster the adaptation of the compressor capacity is performed.

The compressor can be speed controlled in the range from 45% to 100%, corresponding to 2,000 to 4,500 revolutions per min. If the requested compressor capacity is less than 45%, the compressor will start and stop at 2,000 RPM on a PWM basis. As default, the "Compressor Period Time" (g05) is set to 15 minutes. This means that the compressor will be running for a shorter or longer time within this period.

Requested Compressor Capacity	Compressor Speed, Period Time = 15 minutes
0%	Compressor constantly stopped
22%	Pulse width modulation, PWM 7,5 minutes ON (2000 RPM) 7,5 minutes OFF
45%	Compressor constantly running 2,000 RPM
100%	Compressor constantly running 4,500 RPM

The capacity controller contains compressor protection settings to prevent the start/stop of the compressors from occurring too often (g03 and g04).

After initial start, the compressor capacity will be set to 100%, until the reference temperature T_{ref} has been reached. In some applications it might be an advantage to run the compressor at the pull-down capacity for some extra time. Although the air temperature in the cabinet has reached the set point, the goods will still be too warm. For that reason, the pull-down period can be extended, until the "T_{act} below T_{ref} to end Pull Down" (n48) has been reached. After this the PI controller will be preset to a default value, depending on whether the controller is in day or night mode (n53 and n54).

Depending on the size of the deviation between the reference temperature T_{ref} and the actual temperature, the requested capacity will now be increased or decreased faster or slower. The speed of adapting the requested capacity depends on the settings for the PI controller.

Due to different load profiles for the different applications, the controller has a "smart setting for PI control" (n30) application. The default setting is medium control, but if a faster adaptation of the requested compressor capacity is needed, this can be changed to fast or even very fast control. On the other hand, this can also be set to slow or very slow, if the cooling application requests this. In situations, where one of these settings is not suitable for the application, the PI settings can be adjusted by the customer (n35 to n43). Contacting the supplier of the controller is recommended for optimal adjustment. Although, the right smart setting or individual adaptation of the PI controller has been chosen, a cabinet temperature exceeding a pre-defined minimum or maximum limit, compared to the temperature reference T_{ref} could occur.

As soon as the temperature reaches the limit of "T_{act} above c to start Pull Down limit" (n47) or the limit of "T_{act} below T_{ref} to start pull up limit" (n46), a timer "Temperature out of range timeout" (n50) begins. After this timer has elapsed, a forced pull-up or pull-down starts. The timer will be reset as soon as the temperature is back within the min. and max. limits.

If a pull down is requested, the compressor capacity will be preset to "Optimized pull down capacity" (n52). This capacity will be applied, until the time "Optimized pull down time" (n51) has elapsed. Hereafter, the compressor will run at 100%, until the set point has been reached.

If a forced pull-up has been initiated, the compressor will stop, until the temperature exceeds "T_{act} above T_{ref} to end pull-up" (n49).

If the digital input DI1 is defined to be used as a door switch, it is possible to stop the evaporator fan when the doors are open. It is also possible to override the capacity controller at the same time. The compressor can be stopped "Compressor capacity switching on door open" (n22) or the compressor capacity can be preset by "Compressor capacity at door open" (n23). As soon as the door is shut again, the capacity controller will resume with the same capacity as prior to the door opening.

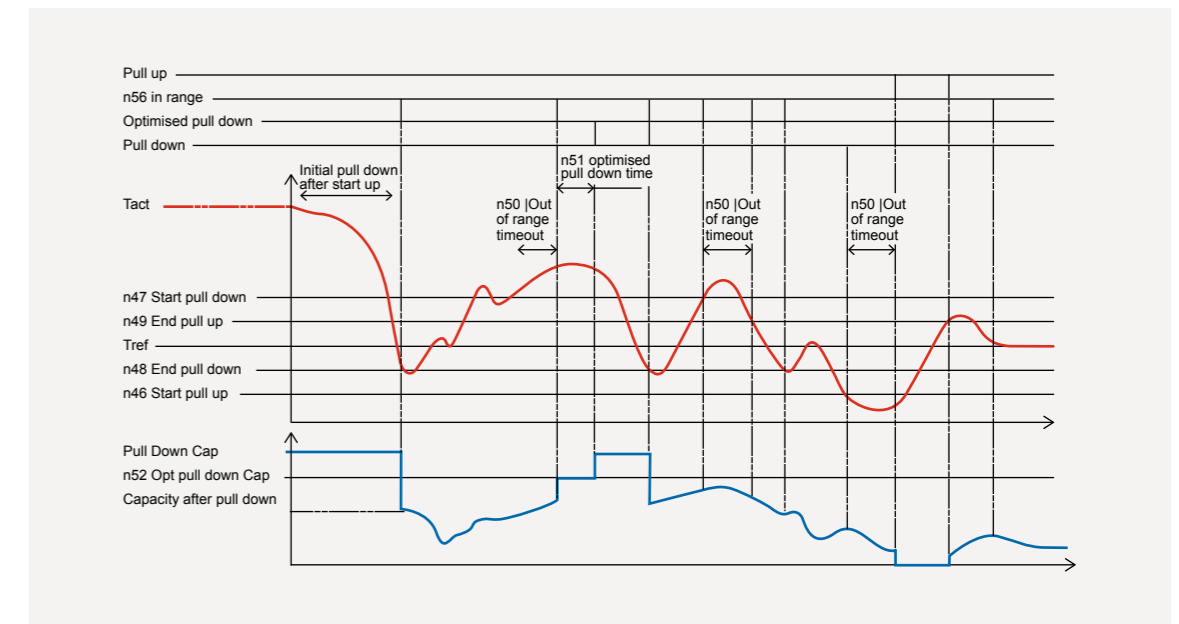

Defrosting:

The PI controller is suspended during a defrosting sequence. Prior to defrosting, the actual requested compressor capacity is stored in the memory. Once defrosting is complete and after pull-down of the temperature to a set point, the normal capacity control is resumed, based upon the previous stored capacity.

Emergency cooling:

In the event of sensor errors, the capacity controller stops and the compressor capacity is preset to a customer specified value, "Emergency cooling capacity during S1/S2 error" (n21). For more information, please refer to the chapter Emergency Cooling Function.

Parameter Function	Code	Min.	Max.	Default Setting	Unit
Number of compressors	g01	1	3	1	-
Compressor minimum stop time	g03	1	240	90	sec
Compressor minimum run time	g04	1	240	30	sec
Compressor period time	g05	5	30	15	min
Compressor swap time 0 = None	g06	0	60	1	day
Compressor capacity for starting PWM control	g07	1	100	1	%
Compressor capacity for starting speed control	g08	20	100	45	%
CC Control Mode 0 = Internal temperature control (PID) 1 = External analog signal (AIO1) 2 = External analog signal (AIO2)	g09	0	2	0	-
Capacity compressor 1	g10	0	100	RO	%
Capacity compressor 2	g11	0	100	RO	%
Capacity compressor 3	g12	0	100	RO	%
Actual main compressor/swapped	g13	0	3	RO	-
Compressor start delay	g14	0	60	5	sec

Parameter Function	Code	Min.	Max.	Default Setting	Unit
Electronic power up delay	n24	0	240	9	sec
Sensor failure capacity	n21	0	100	60	%
Compressor capacity switching on door open (n23) 0 = Off 1 = On	n22	0/no	1/yes	1	-
Capacity at door open	n23	0	100	50	%
Capacity override select: 0 = Temperature Control 1 = Pause Temperature Control (external) 2 = Stop Temperature Control (external)	n28	0	2	RO	-
Capacity override value (if n28=1)	n29	0	100	RO	%

Parameter Function	Code	Min.	Max.	Default Setting	Unit
Smart Set: 0 : User defined 1 : Very slow control 2 : Slow control 3 : Medium control (default) 4 : Fast control 5 : Very fast control	n30	0	5	3	-
PID polynomial R1	n35	-50	50.0	-1	-
PID polynomial R2	n36	-50	50.0	0	-
PID polynomial S0	n37	-50	50.0	-4	-
PID polynomial S1	n38	-50	50.0	3,9	-
PID polynomial S2	n39	-50	50.0	0	-
PID polynomial T0	n40	-50	50.0	-4	-
PID polynomial T1	n41	-50	50.0	3,9	-
PID polynomial T2	n42	-50	50.0	0	-
h sampling time	n43	10	600	30	sec.
U _{min} minimum saturation value (high word)	n44	0	100	0	-
U _{max} maximum saturation value (high word)	n45	0	100	100	-
T _{act} below T _{ref} to start pull up limit	n46	-10	0	-3	K
T _{act} above T _{ref} to start pull down limit	n47	0	10	3	K
T _{act} below T _{ref} to end pull down limit	n48	-10	10	0	K
T _{act} above T _{ref} to end pull up limit	n49	-10	10	0	K
Temperature out of range timeout	n50	0.0	30.0	4	min.
Optimized pull down time	n51	0.0	30.0	10	min.
Optimized pull down capacity	n52	20	100	60	%
Default capacity day	n53	0	100	60	%
Default capacity night	n54	0	100	55	%
Out requested capacity (RO)	n55	0	100	RO	%
Controller state: 0=Off, 1=Pull down 2=Pull up 3=In range 4=Out of range Up 5=Out of range down 6=Override	n56	0	6	RO	-

4.7. Emergency Cooling Function

The purpose of this function is to ensure a reasonable level of refrigeration in case of an error in the reference temperature sensor.

For low temperature applications, it is better to run at a high compressor capacity while high temperature applications prefer a reduced capacity to prevent freezing of the chilled goods.

Functional description:

If the sensor required by the application input setup is in a sensor error state, an emergency cling function takes over and presets the requested compressor capacity to "Emergency cooling capacity during S1/S2 error" (n21). The emergency cling function takes over the normal capacity control while all remaining functions will run unaffected.

When normal compressor capacity control resumes, the PI controller will be "released" from the emergency cling level and the requested compressor capacity will adapt to the actual needed capacity.

Restrictions:

The function is overruled by the main switch off, service mode, case clean mode, loading of cabinet, drain function cut out or the defrost mode which do not contribute to the calculation of the requested compressor capacity.

Dependencies:

If a weighting of S1 and S2 is to be used for the input to the temperature reference, the emergency cooling function will only be enabled when both sensors are detected to be defective. If only 1 sensor is defective, the calculation of the cabinet temperature will be based upon the remaining sensor.

Parameter Function	Code	Multiple Apps	Min.	Max.	Default Setting	Unit
Emergency cooling capacity during S1/S2 error	n21	x	0	100	60	%

4.8. Evaporator Fan Control

The evaporator fan can be controlled separately during normal operation, defrost, nighttime operation, and by opening the door opening.

To avoid circulation of warm air in the cabinet, the fan can be stopped when the evaporator temperature is too high.

To reduce noise and power consumption, the controller supports AC fans with 2-wire speed control.

Speed control can be done either by compressor speed or nighttime operation.

To configure the speed control, both parameters for fan control and relays must be set.

Parameter Function	Code	Multiple Apps	Min.	Max.	Default Setting	Unit	Details
Evaporator fan mode: 0=Off 1=Enabled 2=Enabled and fan stop check on T _{defr}	F01	x	0	2	1	-	If fan mode is 2, the T _{defr} temperature is checked according to F04. When exceeding this value, the fan stops. The fan starts again if the temperature at T _{defr} gets below F04-2 K.
Evaporator fan stop on open door 0 = No 1 = Yes	F03	x	0	1	1	-	If set, the fan stops when the door is opened.
Evaporator fan stop temperature (T _{defr})	F04	X	-50	50	10	°C	If the evaporator temperature is higher than F04, the evaporator fan is stopped.
Evaporator fan speed operation: 0 = No speed control 1 = Low speed at compressor cut out 2 = Fan stop during nighttime operation 3 = Low speed during nighttime operation 4 = Low speed at low compressor speed 5 = (4) + fan stop at compressor stop	F05	X	0	5	0	-	
Compressor speed for low Evap fan speed	F06	x	0	4500	0	rpm	If the compressor speed is below F06, the fan is set to low speed. When the speed of the compressor has increased by 200 rpm over F06, the fan returns to high speed.

**4.9.
Condenser
Fan Control**

The condenser fan can be controlled separately during normal operation and defrosting. To reduce noise and power consumption, the controller supports AC fans with 2-wire speed control.

Speed control can be done either by compressor speed or by a temperature sensor (S3) placed at the condenser. The sensor can also be used for issuing a warning or alarm in case of blocked condenser or defect condenser fan.

To configure the speed control, both parameters for fan control and relays must be set.

Parameter Function	Code	Multiple Apps	Min.	Max.	Default Setting	Unit
Condenser fan mode: 0 = Off 1 = Run with compressor 2 = Speed controlled by sensor S3 3 = Always run unless stopped 4 = Run at low speed when compressor stopped	F11	x	0	4	1	-
Condenser fan high speed temperature (S3)	F12	x	-50	85	35	°C
Condenser fan low speed temperature (S3)	F13	x	-50	85	30	°C
Condenser fan alarm temperature (S3) Set to zero the function is disabled	F14	x	0	85	0	°C
Condenser fan low speed as function of compressor speed 0 = constant high speed 4500 = constant low speed	F15	x	0	4500	2500	rpm
Condenser fan speed during defrost 0= Off 1= Low speed 2= High speed	F16	x	0	2	0	-

- If F11 is set to 1, the fan speed is determined by the speed of the compressor.
 - If the compressor speed is below F15, the fan will run at low speed.
 - When the speed of the compressor has increased by 200 rpm over F15, the fan returns to high speed.
- If F11 is set to 2, the fan follows the compressor, but the speed of the fan depends on the S3 temperature. When S3 is above or equal to F12 it runs at high speed. When below F13, it will run at low speed. If sensor S3 has a failure the fan will run at full speed.
- Defrost control:

The condenser fan can be stopped during hot gas defrost to optimize the power for defrosting. If the controller becomes too hot, the condenser fan will be started and run until defrosting has finished.

**4.10.
Defrost Control**

The defrost control can handle systems with hot gas, natural, and electric defrosting

Scheduling of defrost can be based on a timer counting of the elapsed time to next defrost or real time clock controlled hours.

The defrost execution contains algorithms to minimize risk of liquid return to the compressor.

- After defrost has started, the hot gas valve is activated.
- The compressor is kept stopped for the time defined by parameter d43
- The compressor runs at low speed for the time defined by parameter d44.
- After d44, the compressor continues at high speed until end of defrost.

During the defrost, the condenser fan can be stopped to improve the defrosting. The fan will turn on in case the electronic unit needs cooling.

Parameter Function	Code	Min.	Max.	Default Setting	Unit
Defrost temperature	U37	-300.00	+300.00	RO	°C
Defrost stop temperature	d02	0	25	6	°C
Max. defrost duration	d04	0/skip	240	45	min.
Drip off time	d06	0/skip	60	0	min.
Delay for evap. fan start after defrost	d07	0	60	0	min.
Evap. fan start temperature	d08	-50	0	-5	°C
Evap. fan cut-in during defrosting	d09	0/no	1/yes	1/yes	-
Defrost sensor: 0 = Stop on time 1 = S4 2 = S2 3 = S1	d10	0	3	0	-
Heat in drip tray. Time from defrosting stops to heating in the drip tray is switched off.	d20	0	240	30	min.
Drain preheat. Time to heat up the drain before starting defrosting.	d40	0/skip	240	0	min.
Pull-down time. The maximum time that the system is doing pull-down after defrosting.	d41	0	240	0	min.
Hot-gas capacity. The capacity that is used for hot gas defrosting. Capacity after d44.	d42	0	100	0	%
Compressor time at 0 speed after hot gas start	d43	0	60	0	min.
Compressor time at low speed after d43	d44	0	60	0	min.
Max hold time after coordinated defrost	o16	0/skip	240	20	min.
Capacity during drip off time	L95	0	100	0	%
Capacity during drain preheat	L96	0	100	0	%

4.10.1. Defrost Execution Details

Hot gas defrost sequence if defrost temperature sensor is used:

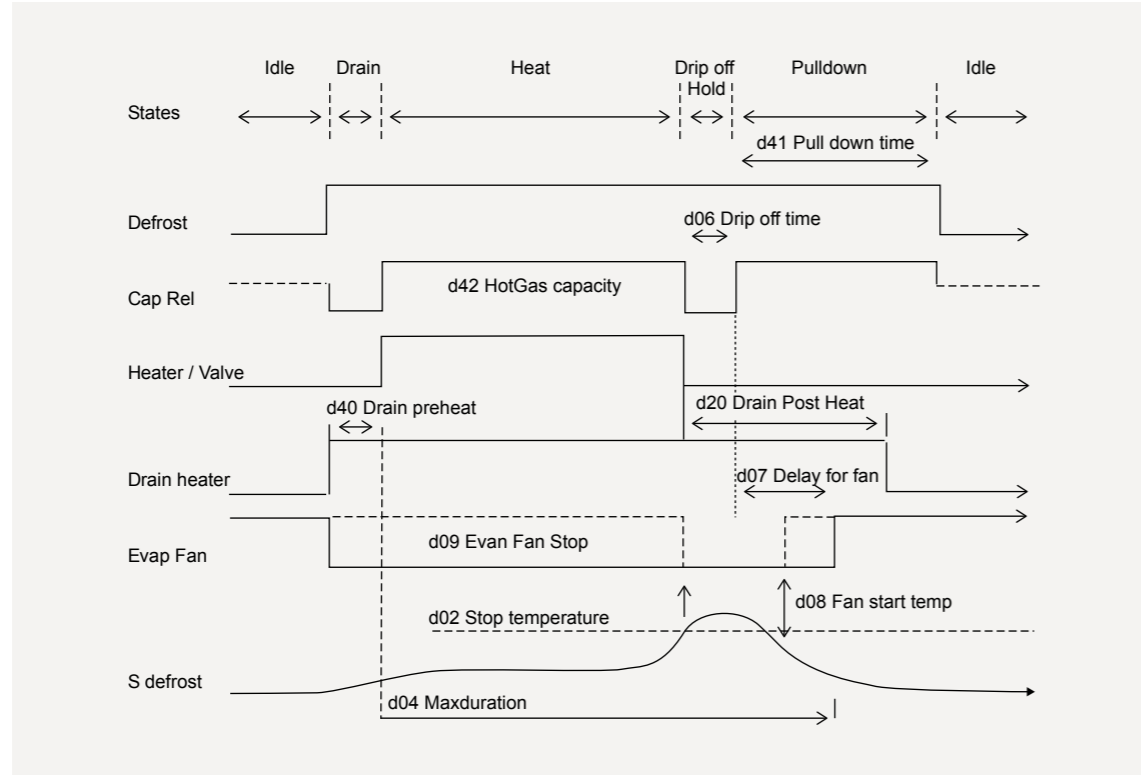

Hot gas defrost sequence if no defrost temperature sensor is used:

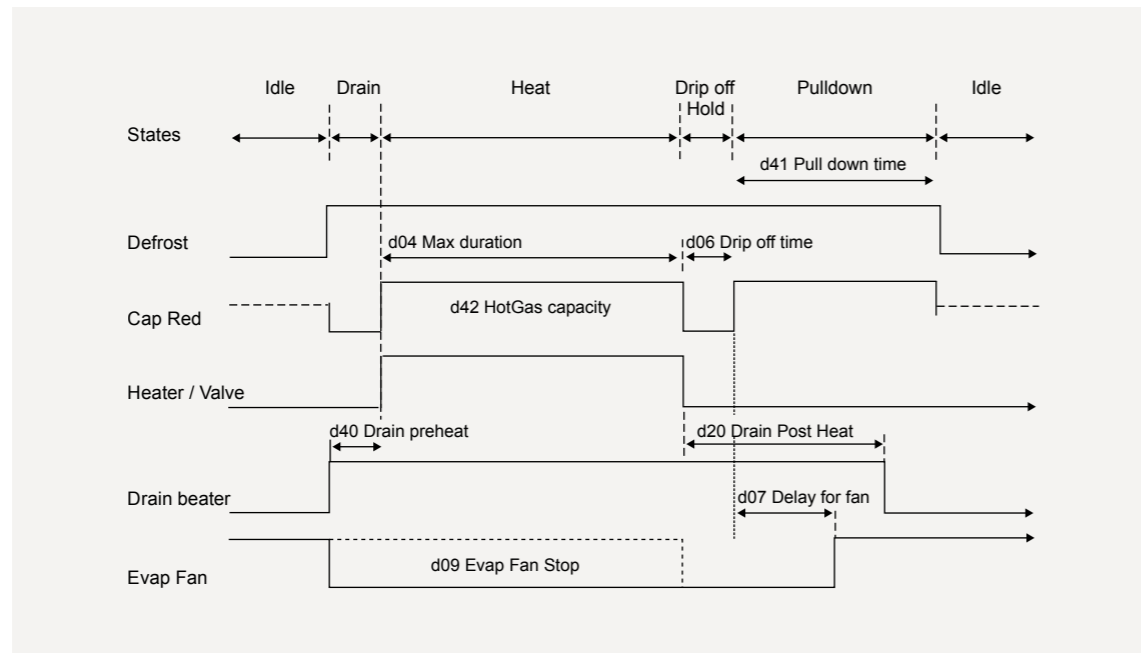

For electrical or passive defrost, set the parameter L95, L96, and d42 to 0%.

4.10.2. Defrost Scheduling

Defrost can be done by timer, real-time clock, or manually.

1. Timer initiated defrost:

The timer starts when the defrost has ended. The timer counts elapsed time, not taking compressor stops into consideration.

2. Clock controlled defrosting:

Defrost is started by the internal real-time clock.

3. Manual defrost:

Defrost can be initiated by pressing a button on the display or by using an external push button, connected to the DIO. The interval between manual defrosting can be limited by a parameter. Manual defrosting can be used in combination with automatic defrosting.

Parameter Function	Code	Min.	Max.	Default Setting	Unit
Method: 0 = Never 1 = Once per day 2 = Multiple times per day fixed hour 3 = Multiple times per day timer based 4 = Not used	d90	0	4	0	-
Interval between defrost start (timer based)	d03	1.0	168.0	4.0	hrs.
Allow remote start of defrost 0 = Disabled 1 = Enabled	d60	0	1	0	-
Enable start from local MMI 0 = Disabled 1 = Enabled	d61	0	1	0	-
MMI min. interval between manual defrost. The time to disable defrost start after a defrost. If set to zero: no limit is used	d62	0	168.0	21.0	hrs.
Hour to start defrosting or Hour to start defrosting on Sundays	d71	-1(skip)	23	-1	hrs.
Hour to start defrosting or Hour to start defrosting on Monday	d72	-1(skip)	23	-1	hrs.
Hour to start defrosting or Hour to start defrosting on Tuesday	d73	-1(skip)	23	-1	hrs.
Hour to start defrosting or Hour to start defrosting on Wednesday	d74	-1(skip)	23	-1	hrs.
Hour to start defrosting or Hour to start defrosting on Thursday	d75	-1(skip)	23	-1	hrs.
Hour to start defrosting or Hour to start defrosting on Friday	d76	-1(skip)	23	-1	hrs.
Hour to start defrosting or Hour to start defrosting on Saturday	d77	-1(skip)	23	-1	hrs.
Hour to start defrosting	d78	-1(skip)	23	-1	hrs.
Start time for defrost in minutes Days are equal to d7x values D81 for Sunday, D82 for Monday, ...	d81..88	0	59	0	min.

4.11. Melt Function

On high temperature cabinets, there is a risk of ice flakes forming on the evaporator which could block the air flow when the thermostat has not made cut out for a certain time period.

In order to avoid this, the melt function will initiate a forced stop of the compressor with regular time intervals.

During the stop period the ice flakes will be transformed into solid ice and therefore prevent the air passage through the evaporator from becoming blocked.

During defrosting, the display will show the "DeF" code.

On high temperature cabinets, there is a risk of ice flakes forming on the evaporator which could block the air flow, when the thermostat has not been made to cut off for a certain time period.

In order to avoid this, the melt function will initiate a forced stop of the compressor with regular time intervals.

During the stop period the ice flakes will be transformed into solid ice and therefore prevent the air passage through the evaporator from becoming blocked.

During defrosting, the display will show the "DeF" code.

The defrosting function is divided into two parts.

- The defrosting part, where the compressor stops and the evaporator fan continues to run. The stop period is determined with "Duration of defrosting period" (r17)
- The cool down period, where the compressor is running at 100%, until the temperature set point has been reached. After this, the capacity controller resumes with the same compressor capacity as before the start of a defrosting cycle

The condition to start a defrosting period is as follows:

- The melting interval "Time between melt periods" (r16) is set different to zero
- The compressor has been running continuously during the defrosting interval
- The sensor for T_{act} has been without fault
- The T_{act} (U17) is between the lower limit "Lower temperature limit to start melt" (r19) and the upper limit "Higher temperature limit to start melt" (r20)
- The temperature controller must be in range at this time

During the defrosting and cooling action, the following conditions can terminate the sequence:

- The sensor for T_{act} has a fault
- The defrosting function is overruled by an operation mode with a higher priority.
- The T_{act} (U17) is not between the lower limit (r19) and the upper limit (r20).
- The defrosting interval (r16) is set to zero.

The defrosting function is inactive if "Time between defrosting periods" (r16) = 0 or "Duration of defrosting period" (r17) = 0.

At thermostat air sensor error, the defrosting function is inactive.

Furthermore the function will be inactive, when "The air" (u17) is above the "High Lim air" (a13) or when the NLV is in pull down mode.

Note that the Melt function only makes sense on applications with evaporator fans.

Parameter Function	Code	Multiple Apps	Min.	Max.	Default Setting	Unit
Time between defrosting periods 0 = Off	r16	X	0	10	0	hrs.
Duration of defrosting period	r17	X	1	10	0	min.
Duration of cool down period	r18	X	0	10	0	min.
Lower temperature limit to start defrosting	r19	X	-15	15	-5	°C
Higher temperature limit to start	r20	X	-15	15	10	°C

4.12. Case Cleaning Function

The purpose of the case cleaning function is to assist the daily user in cleaning of the cabinet. If the function is enabled, the daily user can initiate and terminate cleaning of the case by pushing a button on the cabinet.

Functional description:

If the DI1 is defined to be used for case cleaning, the following sequence will start, as soon as the button is activated:

First activation:

- The actual compressor capacity is stored in the NLV memory to be resumed at the end of the cleaning sequence.
- De-icing of the evaporator starts. Depending on the setting of the "De-icing method" (o47), this can either:
 - stop the compressor and the evaporator fan (if present) continues to run, until the defrost stop temperature has been reached; or
 - start a defrosting sequence, until the defrost stop temperature has been reached. This can be electrical, hot gas, or natural.

At the end of manual cleaning, the daily user activates the button a second time.

Second activation:

- A new pull down of the cabinet temperature is initiated, until the set point has been reached.
- Normal temperature control resumes with the same compressor capacity as before the start of a cleaning sequence

The parameter "Case cleaning status" displays the status of the sequence:

1. No cleaning initiated
2. De-icing of the evaporator is in progress. This can be either electrical, natural, or hot gas defrosting.
3. Waiting for the daily user, to finish the cleaning and to activate the button a second time.

Display readout:

Readout on the display during the cleaning cycle and after following pull down: "deF"

Alarm handling:

During case cleaning, all alarm messages are disabled (except for the case cleaning message and sensor errors). The alarm delay for high temperature alarms is set by the parameter "Delay timer for high temperature alarms, after initial startup or defrosting" (A12).

Defrost:

A normal defrost sequence cannot be started, and an ongoing defrost will stop during case cleaning.

Stop of case cleaning:

The user can stop case cleaning by using the same signals as for initiation. Case cleaning can also be terminated by setting the main switch to OFF.

Parameter Function	Code	Min.	Max.	Default Setting	Unit
Case cleaning status 0: Not started 1: Deicing 2: Waiting for cleaning	o46	0	2	0	RO
Deicing method 0 = Compressor off 1 = Execute defrost	o47	0	1	0	-

4.13. Nighttime Operation

During night, the need for cooling might reduce due to less opening of doors, no light, blind curtains, etc. Furthermore, it might be necessary to adjust the weighting of the temperature sensors due to changed airflow and load.

Nighttime operation can be done by:

1. Defining an application for nighttime operation. This allows multiple actions during the night.
 - Different weighting between sensors due to changed temperature balance
 - Control light
 - Change in defrost interval
 - Increase in set point
 - Reduction in fan speed of evaporator fan
2. Simple nighttime mode by changing set point.

The nighttime mode can be selected by:

- Signal from a digital input
- Remote by Modbus
- Action timer

4.14. Blind Control

The purpose of the blind control function is to manage the blinds in front of the cabinet in sync with the daytime / night mode of the controller. The function can be overridden by the digital input which will put the curtain into day position at closed DI.

Functional description:

The relay for the blind control will be engaged during nighttime mode. For some control systems, a 1 pole change over relay will be needed to run the curtain motor in 2 different ways. This option is possible on relay 8. To activate the blind function, the parameter "Blind function" (o62) must be set to "Night".

The NLV can be set to nighttime mode via one of the following methods:

- Manually via settings in the controller
- Via a signal on the digital input, depending on settings in the controller
- Via the "Day/Night function" in the master control system
- Timer controlled
- Remote by master controller
- Door contact
- Display

Parameter Function	Code	Min.	Max.	Default Setting
Blind function 0 = None 1 = Night	o62	0	1	0

Restriction:

If the DI is defined for curtain control, a closed DI will override the above-mentioned inputs and force the curtain into day position.

4.15. Light Control

The purpose of the light control function is to manage the lights in the cabinet.

Functional description:

The relay output for light/curtains is a 1 pole change over relay. The relay is engaged during nighttime mode.

The NLV can be set to nighttime mode via one of the following methods:

- Manually via settings in the controller
- Via a signal on the digital input, depending on settings in the controller
- Via the "Day/Night function" in the master control system
- Timer controlled
- Remote by master controller
- Door contact
- Display

Restriction:

Safety functions during daytime/nighttime control:

When the night setting signal is lost, the controller will revert to the default day condition. For that reason, the night signal from the front end must be retransmitted (master control block) to keep the nighttime mode in the NLV. Otherwise, the NLV goes into daytime mode (light on and curtain up).

Operation of light is not prioritized. For instance will manual operation by switch and display over-rule automatic light mode[Sinn unklar]. If the light is set manually to on, the nighttime mode and timer can still turn the light off. The light will switch off if controller is set to stop and during power-up.

Parameter:

Parameter Function	Code	Multiple Apps	Min.	Max.	Default Setting	Unit
Configuration of light function: 1 = Daytime/Nighttime operation 2 = Door 4 = Remote controlled via 'o39' 8 = Timeout detection enabled (network loss)	o38	x	0	15	1	-
Activation of light relay via remote 0 = Off 1 = On	o39		0	1	0	-
Light turn-off delay after door closes	o40	x	0	240	2	min.
Inverse Light function 0 = Disabled 1 = Inverse	o41	x	0	1	0	-

4.16. Real Time Clock and Control Timer

The controller contains a real time clock with battery backup. This RTC is used for the control timer, which can operate different functions. In addition, the RTC is used for the defrosting schedule. For defrosting, please refer to the section Defrost control function.

Functional description:

The real time clock is powered from the internal NLV supply. In case of a power outage, the RTC will be powered from the internal battery backup.

The RTC can be setup in one of the following ways:

- via the local display
- Tool4Cool®
- via the front-end system

If the setup is done via the local display, please follow the instructions in the section Local display indications and menu.

When T4C is used for setting up the RTC, you do not need to enter a value for each RTC parameter. Instead, it is possible to push the "Set PC time to NLV" in the T4C menu structure.

Based on the RTC, the NLV controller also has a control timer, with a daily schedule.

With this control timer, it is possible to intervene into the normal control of the NLV.

The parameter "Control timer Function" (t84) has the following options:

- 0 = None. No override of the NLV.
- 1 = Do not use.
- 2 = Main Switch. The NLV is put into stop mode as long as the control timer is active.
- 3 = Night operation. Selection of daytime/nighttime mode via the internal control timer.
- 4 = Light. Light ON/OFF as function of the control timer.
- 5 = Application changeover. Selection of an application as a function of a pre-defined schedule in the control timer.
- 6 = Relay out. ON/OFF control of a pre-selected relay, as function of the control timer.

Parameter Function	Code	Min.	Max.	Default Setting	Unit
Hour	t07	0	23	set	hrs.
Minutes	t08	0	59	set	min.
Day	t45	1	31	Set	day
Month	t46	1	12	Set	month
Year	t47	9	99	Set	years
Control timer start hour	t80	0	23	0	hrs.
Control timer start minute	t81	0	59	0	min.
Control timer stop hour	t82	0	23	0	hrs.
Control timer stop minute	t83	0	59	0	min.
Control timer function 0 = None 2 = Main switch 3 = Night operation 4 = Light 5 = Application changeover 6 = Relay out	t84	0	6	0	-

4.17. Alarm Handler

The alarm handler manages the alarms for the different types of errors.

The alarms can be indicated on the local display and activated by relay or via the Modbus.

All alarms in the controller are split into 5 different groups, depending on type of error:

Group	Fault Type	Description
0	User application faults	Application faults are faults that are caused by trouble in the application itself, e.g. the cooling circuit or missing air to the machinery room
1	System related faults	System faults are related to trouble emerging from external condition to the cabinet. E.g. over voltage on the mains.
2	Sensor faults	Sensor faults are faults that are detected on the sensors if they are used.
3	Electronic faults	Electronic faults are trouble caused by the electronics.
4	Motor faults	Motor faults are all troubles influencing the motor causing it to fail to operate. For instance, overload of the cooling system, e.g. too high pressure

4.17.1. Application Related Alarms

The application alarms are alarms that relate to the cabinet and are caused by using the cabinet improperly.

Alarms are stored in the event list and can be read out by Tool4Cool®. For some of the alarms the values related the alarm are stored, too.

Alarm Groups	Code	Name
Group 0 User application faults	E06	E06 Defrost heat timeout
	E05	E05 Defrost hold timeout
	E16	E16 Fatal alarm on DI
	E04	E04 Door open alarm
	E15	E15 General I/O alarm
	E76	E76 No valid application selected error
	E50	E50 Slave address conflict
	E51	E51 DI02 SWI not enabled
	E52	E52 Capacity too high
	E53	E53 AIO misconfiguration
E91	E91 General I/O double function failure	

4.17.1. Application-Related Alarms

Alarm Groups	Code	Name
Group 1 System-Related Errors	E81	E81 Motor 1 speed temporarily too high
	E82	E82 Motor 1 speed temporarily too low
	E81	E81 Motor 2 speed temporarily too high
	E82	E82 Motor 2 speed temporarily too low
	E81	E81 Motor 3 speed temporarily too high
	E82	E82 Motor 3 speed temporarily too low
	E92	E92 PCB high temperature stop
	E93	E93 Supply voltage failure
	E95	E95 Supply voltage frequency failure
	E96	E96 PCB 12V failure
	E99	E99 Inverter 2 temperature critical
	E97	E97 Inverter 3 temperature critical
	Err	Err No display communication
	E54	E54 SAE1 Comm fail
	E55	E55 SAE2 Comm fail
	E56	E56 SAE3 Comm fail
	E73	E73 PCB 2 Temperature critical
	E74	E74 PCB 3 Temperature critical
	E92	E92 Inverter high temperature stop
	Group 2 Sensor Errors	E21
E37		E37 Condenser fan temperature stop
E43		E43 Low temperature alarm
E20		E20 High temperature alarm
E60		E60 Temperature logger alarm temperature reached
E24		S1 Sensor error
E25		S2 Sensor error
E27		S4 Sensor error
E26		S3 Sensor error
E57		E57 AIO Min. voltage failure
E58	E58 AIO Max. voltage failure	
Group 3 Electronic Faults	UHR	UHR Check clock settings
	UHR	UHR Oscillator for real time clock failure
	E70	E70 Modbus failure
	E70	E70 EKC failure
	E70	E70 Motor 1 voltage failure
	E71	E71 Motor 2 voltage failure
	E72	E72 Motor 3 voltage failure
	E70	E70 Defrost illegal state
	E70	E70 Defrost illegal state
	E70	Main application control state is illegal
E70	E70 Defrost scheduler state is illegal	
Group 4 Motor Faults	E80	E80 Motor 1 error
	E80	E80 Motor 2 error
	E80	E80 Motor 3 error

4.17.2. Alarm Acknowledgement

There are 3 different ways to acknowledge alarms:

- By pushing the reset button on the local display, remotely from a front-end system or auto acknowledge by the controller.
- In the factory setting, the controller is not set to auto acknowledge.
- The function is enabled by setting the parameter "Auto acknowledge" (o84) different to zero.

4.18. Safety Function

The safety stop will disable all peripheral components, such as fans, light, and compressors in case of a fatal failure in the refrigeration system, typically caused by a defective hot-gas valve.

- When the compressor runs and the temperature exceeds the maximum value after a given time, the system is considered defective, the compressor is stopped and all relays are de-activated.
- The function is disabled during defrosting.
- To restart the system, the power must be reapplied or the test or stopped mode must be selected.

Functional description:

The safety function monitors a predefined temperature after a defrosting sequence. The temperature is selected with the parameter "Check temperature" (P50). If the compressor is running and the hot gas valve is closed properly, this temperature is expected to be below the "Maximum Check value" (P50), within a predefined time, "Time after compressor start to check" (P51). If this isn't the case, the compressor will stop and an alarm generated.

Parameter Function	Code	Min.	Max.	Default Setting	Unit
Check temperature: 0 = None 1 = T _{defr} 2 = T _{act} 3 = S3	P50	x	0	3	
Time after compressor start to check	P51	x	0/Always	240	min.
Interval between checking's	P52	x	0	240	min.
Maximum check value (P50)	P53	x	-50	50	°C
Emergency cooling capacity during S1/S2 error	n21	x	0	100	%

4.19. Event Logging

To analyze information during the electronic and systems lifetime, the NLV has a logging system, which tracks events such as alarms, change of settings, or local events initiated by the user.

Functional description:

The event logger will show all events in a chronological order, starting with the most recent event on top. The event logger can hold up to 200 events, before the logger is full. In such a case, the oldest event at the bottom will be deleted and substituted with the latest on top. In the "Time" column the time of occurrence is listed. The 2nd column "User" shows who initiated the event. The following initiators can create an event:

- System: For example temperature alarms, controller in service mode, logger alarms, max. defrost time exceeded
- Tool4Cool®: For example change of settings
- MMI: For example change of settings, acknowledge of alarms, controller in stop mode, application change over, defrost start
- Third-party front end: For example application change over, defrost start, alarm acknowledge, etc.

4.19.1. List of Possible Events

The following events are useful to track changes and operations during the life of the control unit

T4C event Text	T4C event Value 1	T4C event Value 2	Description
Event database cleared			The event database was cleared.
Parameter changed – [Parameter name]		New value	A parameter has been changed. (The parameter name is in the brackets.)
User-connected	System, Tool4Cool®, Secop Front end, Third-party front end, Supply chain FFT, Supply chain ICI, Supply chain RA, OEM production, MMI		When a new user uses the system a logging of the event will be done in order to track who has made changes.
Mains voltage detected	115 V 230 V		This event is normal after powering up the system.
Temperature log cleared			The temperature log has been cleared.
Automatic baud rate change detected	9600 baud 19200 baud		The baud rate has been automatically changed.
System boot			The system has started.
Acknowledge of alarms			The alarm has been acknowledged by the user.
Factory settings stored			The factory settings have been stored in the database.
Factory settings restored			The factory settings in the database have been restored.
A220 Case cleaning completed			This alarm shows that case cleaning has been completed.
A226 Controller in service mode			This alarm shows that the controller has been set in service mode.

4.20. Service Mode

Accessing the service mode makes it possible to manually set the outputs and read the status of the inputs. This improves the service ability of the whole cabinet.

Functional description:

To protect the NLV against unauthorized setting modifications, the NLV is protected with access codes for the different user levels. To access the Service level, the appropriate access code for the service level "Access code service" (o07) must be entered first.

In the service level it is possible to read different measurements, as well as force the relay outputs ON or OFF and force the compressor to run at different speeds.

Readings:

In the service level, the following readings are available:

Code	Function	Description
L50	PCB temperature	Readout of the controller temperature on the circuit board
L51	Inverter temperature	Readout of the controller temperature on the inverter module
L52	Mains voltage	Readout of mains supply voltage
L53	Mains frequency	Readout of mains supply frequency
L60	Compressor manual control	Shows that the compressor is in manual mode
L61	Compressor actual state	Indication of whether the compressor is running or not
L62	Compressor manual speed percentage when running	Set point of the actual compressor speed, in % of the variable speed band during manual control. 0% means compressor runs at minimum speed and 100% means that the compressor runs at max speed during service mode.
L63	Compressor actual speed percentage when running	Readout of the actual compressor speed, in % of the variable speed band during manual control. 0% means compressor runs at minimum speed and 100% means that the compressor runs at max speed during service mode.

Furthermore, all temperature measurements can be read out. To check the correct reading, compared to the actual sensor temperature the below table can be used.

NTC temperature table for S1, S2, S3, and S4

T (°C)	B25/100 = 3980 K, R25 = 5000 Ω, TR = 0°C		
	Rnom(Ω)	Rnom(Ω)	Rnom(Ω)
-40	169160	159350	178970
-35	121800	115390	128200
-30	88766	84552	92979
-25	65333	62555	68111
-20	48614	46778	50450
-15	36503	35291	37715
-10	27680	26883	28478
-5	21166	20646	21686
0	16330	16003	16657
5	12696	12386	13006
10	9951	9670	10232
15	7855	7604	8105
20	6246	6025	6467
25	5000	4806	5194
30	4029	3859	4198
35	3266	3118	3414
40	2665	2535	2794
45	2186	2073	2298
50	1803	1705	1901
55	1495	1419	1581
60	1247	1172	1321
65	1044	979	1110
70	878.9	821.7	936.1

Access levels:

Once the service level code has been entered, the access codes for the different access levels can be modified:

Code	Function	Description
o05	Access code end user	Access code for the end user level on the display
o06	Access code installer	Access code for the installer level on the display
o07	Access code service	Access code for the service level on the display
o08	Access code OEM lab	Access code for the OEM level on the display

Activation of outputs:

Before it is possible to activate the relays ON/OFF, the service mode must be activated via the parameter "Service mode" (p83). There are 5 different service modes available:

1. Normal, control mode
2. Service mode
3. Customer lab mode, only to be used in the OEM lab for running special approval test, only accessible with OEM key
4. Secop test mode
5. Supply chain test mode

When the NLV controller is set in service mode, all relays are switched off, and the compressor speed is set to zero. When the controller is set back into normal control all relays are set back into same state as before entering the service mode, and the compressor resumes with the same capacity.

The 8 relays R1 to R8 can be set to ON and OFF with the parameters "Relay X Manual control" (P84 to P91). When the controller is taken out of the service mode and put into the normal control mode, the normal cabinet control will be resumed regardless of the actual states of the relay in the service mode.

4.21. Rail Heater Control

The rail heater function is intended for glass heating, rail heating, or frame heating.

The rail heater is controlled by on and off pulsing of the rail heater relay.

There are two ways to control energy consumption:

- With different duty cycle rates during night and day condition
- With different duty cycle rates based on a %RH signal received from the front-end system

The rail heat is off when the controller is in stop mode. During the defrost, melt, and case-cleaning modes, the heater is on 100%. During normal operation, the function is determined by parameter O85.

Parameter Function	Code	Multiple Apps	Min.	Max.	Default Setting	Unit
Rail heat on-time during daytime operation	o41	x	0	100	100	%
Rail heat on-time during nighttime operation	o42	x	0	100	100	%
Rail heat period time (on-time + off-time)	o43	x	10	60	10	min.
Rail heat control 0=not used 1 = pulse width control with timer function (o41, o42, and o43) 2 = pulse control with dew point function	o85		0	2	0	
Dew point value where the rail heat is minimum	o86		-10	50	8	°C
Dew point value where the rail heat is 100% on	o87		-9	50	17	°C
Lowest permitted rail heat effect in %	o88		0	100	30	%
Highest permitted rail heat effect in %	o89		0	100	100	%
Dew point value received from master controller	o83		-10	50	-	°C

The following graphics illustrates the function of the rail heater control

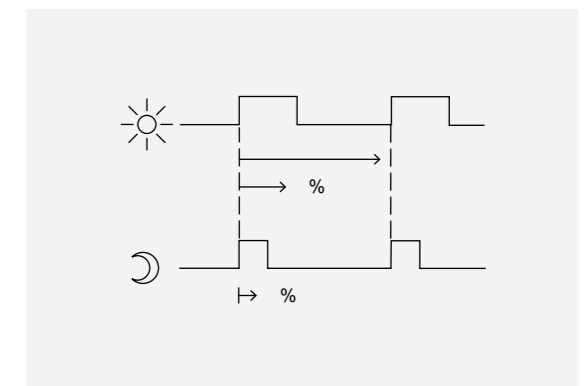
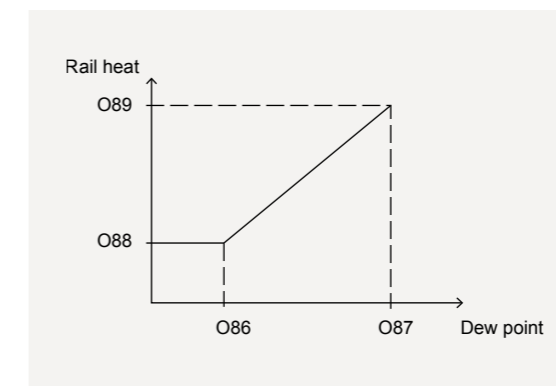

**4.22.
Gearbox**

Large appliances in the food retail and food service sector use multiple compressor cycles to gain more cooling capacity. The reasons are the 150 g propane limitation and a better temperature control.

The multipurpose compressor control function can be used to manage up to three compressors in a master-client system. Where the master is an extended 2nd gen. controller with application board and the clients are second generation multipurpose controller.

Interface description:

The cooling capacity control is possible in two ways:

- Temperature control by internal PID regulator (temperature sensors S1 and S2)
- Temperature control by external analog signal (AIO)
 - The input voltage is from 0V to 5V
- The cooling capacity control strategy is selectable via the parameter CC-Control-Mode (g09)

Speed control of the external client compressors is managed by the DIO2 output with single-wire interface (Modbus protocol).

The gearbox is configurable for the following compressor combinations.

The combination can be selectable via parameter Number of Compressors (g01).

Single V-speed compressor

- The cabinet is equipped with one V-speed compressor

Multiple V-speed compressors

- Only variable speed can be connected as extension compressors.
- The main compressor is the direct controlled compressor by default (Master).
- The first external compressor has the Modbus address 1 by default (Client 1).
- The second external compressor has the Modbus address 2 (Need to be set in Tool4Cool®).

Functional description:

The control of the compressor is implemented as follows:

- If one compressor is selected the input capacity is normalized to a maximum of 100%.
 - If two compressors are selected, the input capacity is normalized to 200%.
 - If three compressors are selected, the input capacity is normalized to 300%.
- Default values are calculated for a compressor with speed range from 2000 to 4500 rpm.
 - 100% capacity equals 4500 rpm.
- When the requested capacity is below compressor capacity for starting PWM control (g07) for a given compressor, it will stop.
 - The runtime is determined by the capacity need.
 - If the minimum capacity of the compressor is higher than the value given by g08, the min compressor capacity is used.
- If the capacity is below $g08 * g01$, no compressor is running at a speed higher than g08.

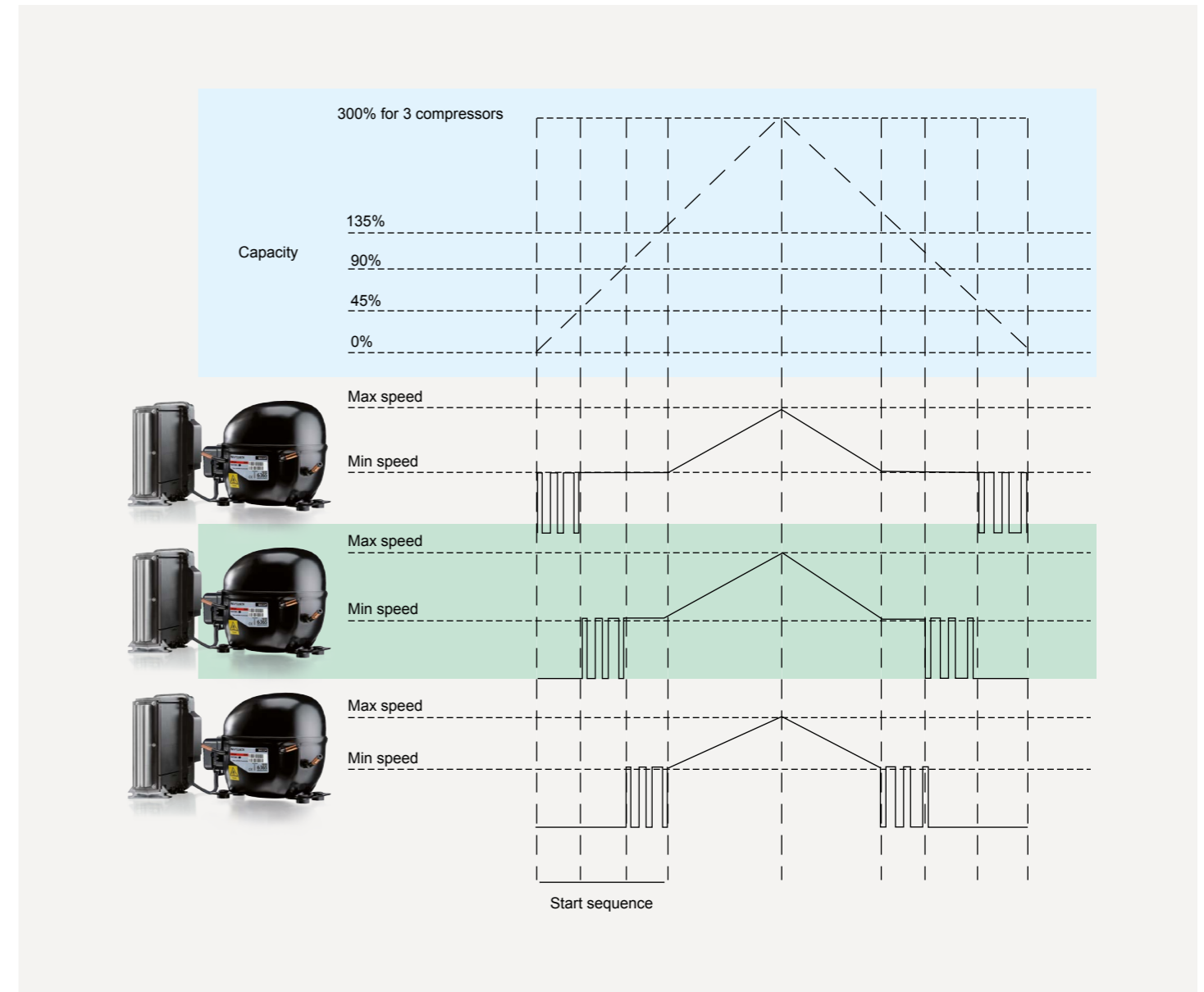
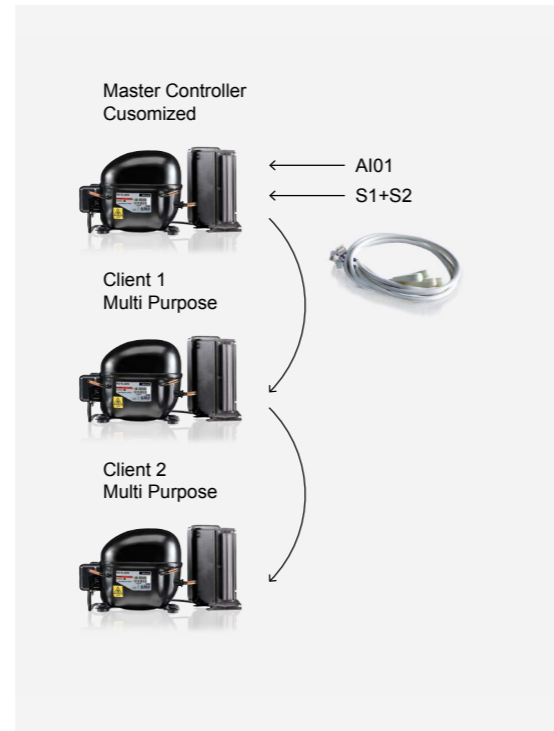

- It is possible to distribute the run time between the compressors
 - If the runtime of the main compressor exceeds the swap time (g06), the compressors swap priority. The compressors will then swap priority again when the new main compressor exceeds the swap time (g06)
- If the parameter CC-Control-Mode (g09) is set to 0 (internal temperature control (PID)): The speed control is depending on the cooling capacity demand from the PID regulator
- The compressors start separately one by one with a compressor start delay (g14)
 - The start delay only applies to compressors 2 and 3.
- The parameter Compressor Period time (g05) gives the cycle time of the PWM mode.
 - The Compressor Period time (g05) may be increased if g03 or g04 cannot be respected.
- The compressor run time control is performed as follows for each compressor:

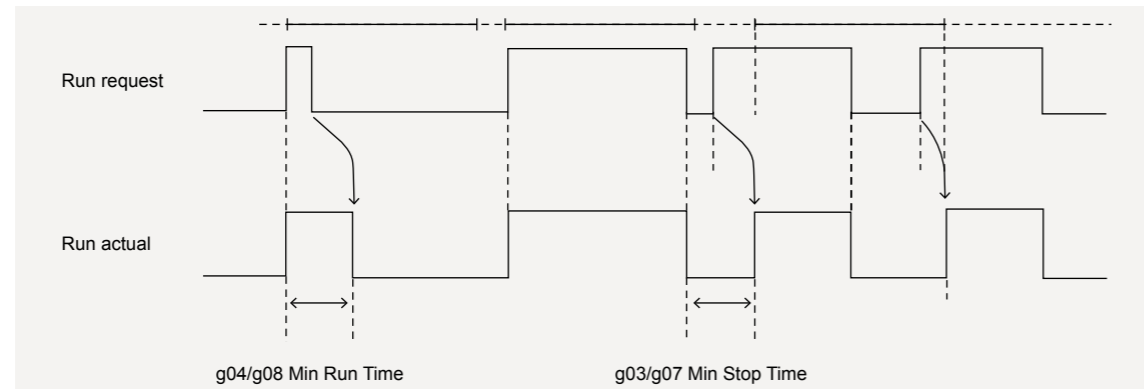

→ If the parameter CC-Control-Mode (g09) is set to 1 or 2 (external analog signal (AIO)).
The speed control is as shown below:

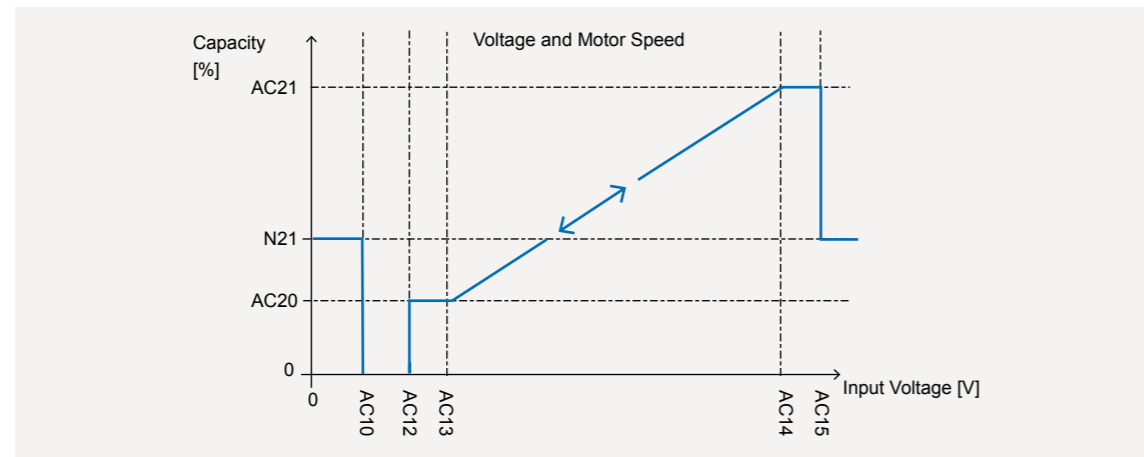

- If the parameter CC-Control-Mode (g09) is set to 1 or 2 (external analog signal (AIO)):
- If the AIO input voltage is below the fallback voltage (AC10) or above the maximum voltage (AC15) the compressors are running at emergency capacity (n21).
 - The compressor speed is calculated by using the following equation:

$$Capacity = \left[\left(\frac{AC21 - AC20}{AC14 - AC13} \right) \cdot (V_{in} - AC13) \right] + AC20$$

Parameter Function	Code	Min.	Max.	Default Setting	Unit
Analog Input Signal	AC01		V		
Requested Motor Speed	AC02		RPM		
Fallback Voltage	AC10	0	5,8	0,3	V
Minimum Voltage	AC12	0	5,8	0,5	V
Voltage Ramp Start	AC13	0	5,8	1	V
Voltage Ramp End	AC14	0	5,8	5	V
Maximum Voltage	AC15	0	5,8	5,5	V
Minimum Capacity	AC20	0	100	0	%
Maximum Normal Capacity	AC21	0	100	100	%

Parameter Function	Code	Min.	Max.	Default Setting	Unit
Number of Compressors	g01	1	3	1	-
Compressor Minimum Stop time	g03	1	240	90	sec.
Compressor Minimum Run time	g04	1	240	30	sec.
Compressor Period time	g05	5	60	30	min.
Compressor Swap Time 0 = None	g06	0	60	1	day
Compressor Capacity for starting PWM control	g07	1	100	1	%
Compressor Capacity for starting speed control	g08	20	100	45	%
CC-Control-Mode 0 = Internal temperature control (PID) 1 = External analog signal (AIO1) 2 = External analog signal (AIO2)	g09	0	2	0	-
Capacity compressor 1	g10	0	100	RO	%
Capacity compressor 2	g11	0	100	RO	%
Capacity compressor 3	g12	0	100	RO	%
Actual main compressor/swapped	g13	0	3	RO	-
Compressor Start Delay	g14	0	60	5	sec.

**4.23.
Storing and
Restoring to
Factory Settings**

The NLV controller contains a "Store to factory" and "Restore to factory" function. With this function it is very convenient for the OEM to program the NLV with their own factory settings. Furthermore, it helps the service engineer to restore a controller of cooling application in case of "lost overview" making modifications or optimizing settings on site.

Functional description:

Storing settings as factory settings "Store to factory setting" (P31) is only possible with an OEM login, the restore function "Restore to factory settings" (P30) is also enabled for the service engineer.

Restrictions:

When activating the "Restore to factory" function, all actual settings in the NLV controller will be overwritten immediately.

Parameter Function	Code	Multiple Apps	Min.	Max.	Default Setting	Unit
Restore the controller settings with the factory settings for the selected application mode. 1 = action	P30	-	0	1	0	-
Replace the controller factory settings with the present settings for the selected application mode. 1 = action	P31	-	0	1	0	-



ANALOG AND DIGITAL INPUTS AND OUTPUTS

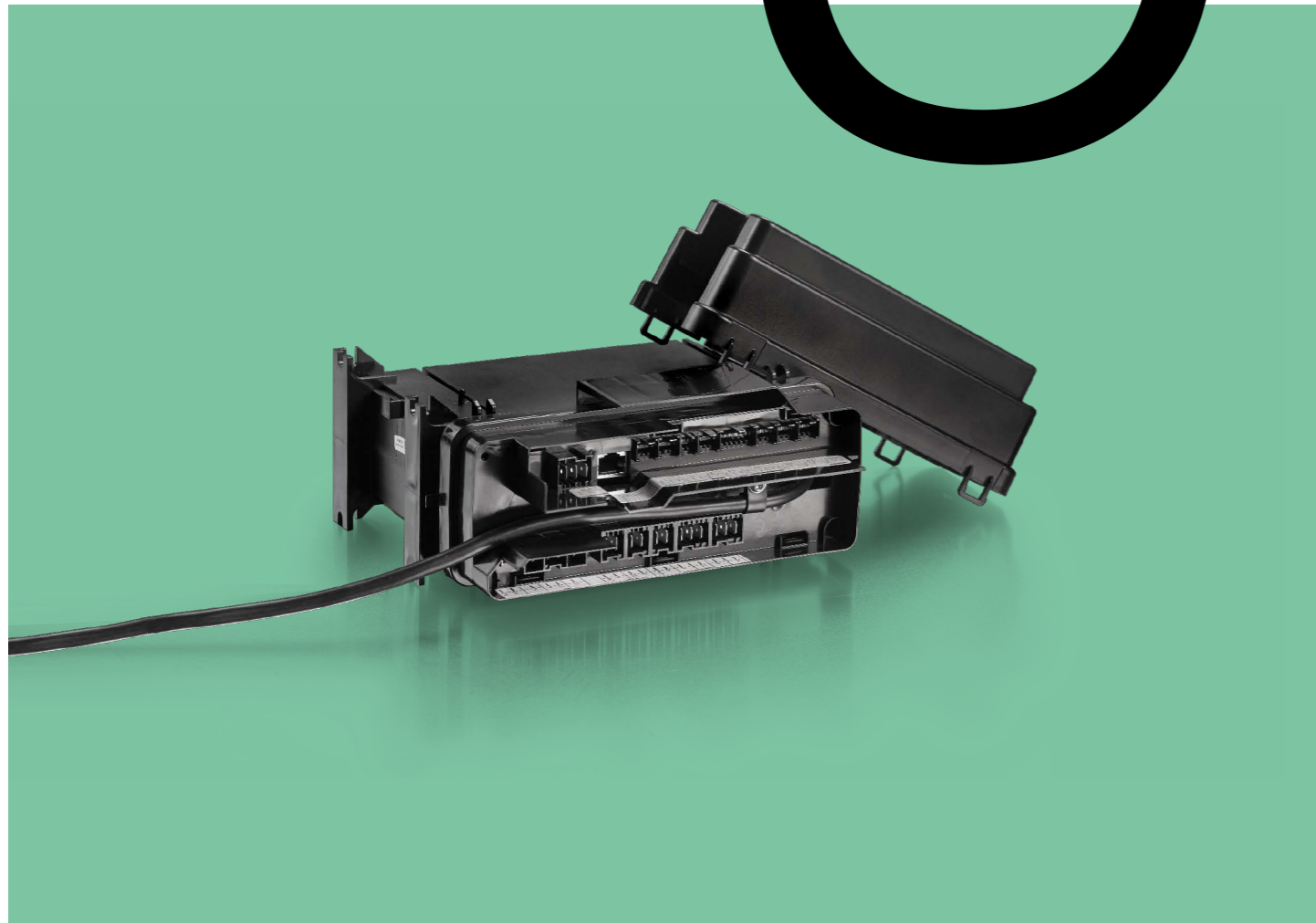

The following table shows the different options for the analog and digital IOs.

Signal	Type	DIO1		DIO2		AIO			
		In	Out	In	Out	In-1	In-2	Out-1	Out2
Door	Switch*	x		x		x	x		
Blind cover	Switch	x		x		x	x		
Main switch on/off	Switch	x		x		x	x		
Defrost	Push-button**	x		x		x	x		
Case clean	Push-button	x		x		x	x		
Alarm	Open drain		x		x				
Application change over	Push-button	x		x		x	x		
Night	Push-button	x		x		x	x		
Light	Push-button	x		x		x	x		
SWI	Communication			x	x				
Evap. Pressure (Not implemented yet)	Analog signal					x	x		
Cond. Pressure (Not implemented yet)	Analog signal					x	x		
Cond. Fan Speed (Not implemented yet)	Analog signal							x	x
Expansion Valve (Not implemented yet)	Analog signal							x	x

*Switch: Contact with 2 stable positions (open/closed).

**Push-button: Contact with 1 stable position (open) and only closed when pushed.

- Analog functions for AIO1 not yet implemented, but the inputs can be used for digital signals.
- Only one IO can be configured for same function, except for door switch. In case of double configuration an alarm will be activated.
- If a short-circuit is made of the 12V supply, the controller will disable the 12V supply, all digital and analog ports, including display. The controller, temperature sensors, relays and the Modbus connection will still be active.
- If the 12V supply is overloaded, the controller will disable the 12V for 10 seconds, then enable it for 1 seconds. This will continue until the overload disappears.

Parameter Function	Code	Multiple Apps	Min.	Max.	Default Setting	Unit
DIO1 function	o02	Yes	0	9	0	-
DIO2 function	o20	Yes	0	10	6	-
Analog input 1 function	o22	No	0	10	0	-
Analog input 2 function	o23	No	0	10	0	-
Alarm time delay on the GIO input	A27	x	0	240	0	min.

CONFIGURING RELAYS

The configuration of the relay outputs is pre-defined from the factory. They can be redefined via settings in the controller. Relay RL1 to RL7 are pre-wired internally in the controller, so that no additional, external junction box is needed.

6

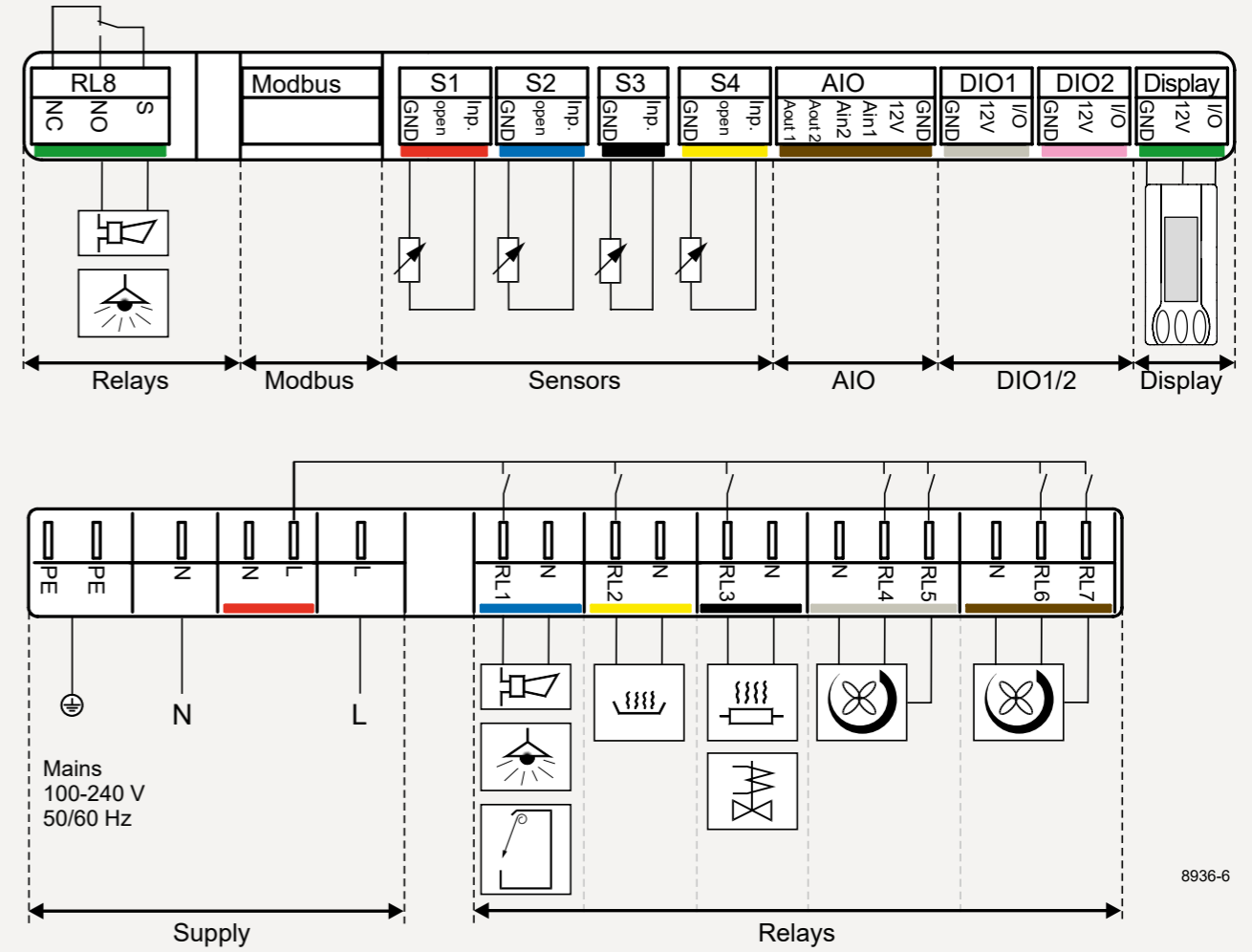

8936-6

The max total load of RL1 to RL7 is 8 amps, which must be shared for these 7 relays. Please see the technical data for the controller.

The relay RL8 is galvanic isolated from the rest of the electronics and can be used in a separate alarm circuit or as a changeover relay in certain applications. The max total load of RL8 is 2 amps

Relay settings must be done for each application. With the Relay configuration parameters L01 to L08, each of the 8 relays can be defined as follows:

	Error Type	Description
0	Always Off	No control functions attached to the relay.
1	Always On	The relay will be activated as soon as the controller is connected to the mains supply.
2	On during operation	The relay will be activated as soon as the controller is energized and has left stopped mode.
3	On during stopped	The relay will be activated as long as the controller is energized and in the stopped mode.
4	Follow Compressor	The relay will stay On as long as the compressor is running.
5	Condenser Fan On	The relay is controlled by the condenser control function.
6	Evaporator Fan On	The relay is controlled by the evaporator control function.
7	Defrost	The relay is attached to the defrost control algorithm. The relay will be On, when defrosting heat is activated. This can be an electrical heater or a hot gas valve.
8	Drain Heater	The relay is controlling the drain heater, which can be energized prior to, during, and after a defrosting.
9	Cnd Fan High Speed	The relay is controlled by the condenser control function and activated when the fan must run at high speed. For dual speed fans only.
10	Rail Heater function	The relay is controlled by the rail heater control function.
11	Blind curtain	It's possible to connect a night blind or curtain to the relay output, which is controlled by the night blind function.
12	Light	Relay will be controlled by the light function.
13	Not used	
14	Evap Fan High Speed	The relay is controlled by the evaporator control function and activated when the fan is run at high speed. For dual speed fans only.
15	Alarm	The relay is used for local alarm indication. The relay will be activated as soon as the controller is energized and no alarms are active. If a galvanic separated alarm is required, the relay RL8 must be used.
16	Temperature logger alarm relay	The relay is used for temperature logger alarm indication.
17	Do not use	Not in use yet.
18	Control timer	The relay will follow the status of the control timer. The relay will be active, when the control timer is active.

Parameter Function	Code	Multi Apps	Min.	Max.	Default Setting	Unit
Relay 1 configuration 0=Always Off 1=Always On 2=On during operation 3=On during stopped 4=Follows compressor 5=Condenser fan 6=Evaporator fan 7=Defrost 8=Drain heater 9=Condenser fan high speed 10=Rail heater function 11=Blind relay 12=Light relay 13=Not used 14=Evaporator fan high speed 15=Alarm relay 16=Temperature logger alarm relay 17=Do not use 18=Control timer	L01	x	0	18	4	-
Relay 2 configuration	L02	x	0	18	0	-
Relay 3 configuration	L03	x	0	18	13	-
Relay 4 configuration	L04	x	0	18	14	-
Relay 5 configuration	L05	x	0	18	0	-
Relay 6 configuration	L06	x	0	18	0	-
Relay 7 configuration	L07	x	0	18	0	-
Relay 8 configuration	L08	x	0	18	15	-

MODBUS

The Modbus used in the controller is based on a RS-485 physical layer. Timing is controlled by an UART. Data is transmitted over a differential pair of wires. D1 is the non-inverted representative of the UART signal; D0 is the inverted signal of the UART.

Please note: the RS-485 is not comparable with a RS-232. Both lines on a RS-485 carry the same data, however on a RS-232, one line is for transmission and one is for receiving. The logic is based on the voltage level, $D0 \rightarrow D1 = 1$ and $D0 \leftarrow D1 = 0$. Both lines refer against each other, whereas RS-232 signals always refer to GND.

Communication is controlled by a bus master. The required supported bus speeds are 9.6 kbit and the standard bit rate 19.2 kbit; other standard bit rates are not supported.

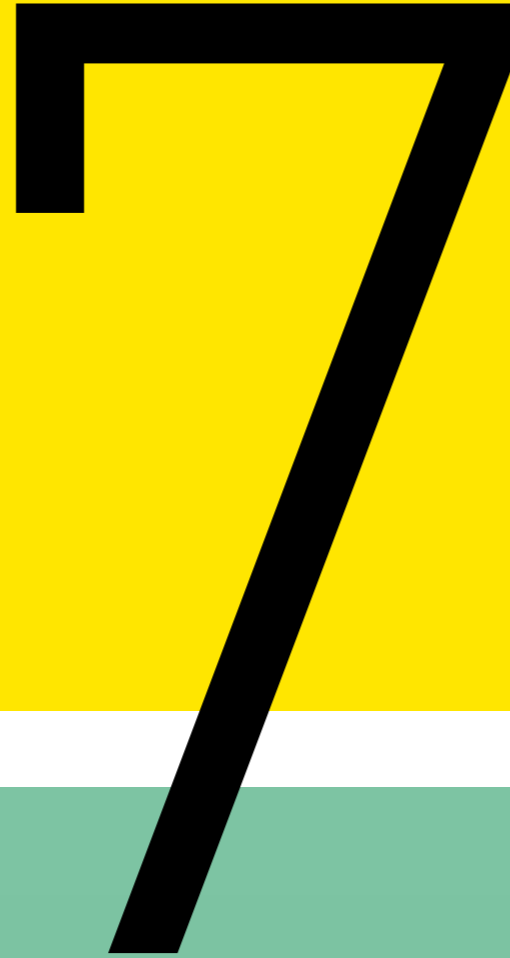

7.1. Short Description of all Bus Parts

Knots

Knots are all devices on a bus which can receive and/or transmit data.

Bus master (head unit, gateway)

The bus master is an active knot which starts the communication process requesting data from other passive knots. There is always only one bus master allowed.

Secondaries

Secondaries such as the controllers are passive knots which should only transmit data when a master requests them. A PNU list containing the data addresses is necessary to setup the bus master.

Data line

The data line in a RS-485 based Modbus is a differential pair. A differential pair is built by 2 wires: D1 and D0. The logic is based on the voltage level, $D0 \rightarrow D1 = 1$ and $D0 \leftarrow D1 = 0$. The differential pair should always be together in a twisted pair.

For a minimum setup a bus master, a secondary, and the data line between them is necessary. All the following items are recommended; they will increase the performance and reliability significantly.

Common line

The common line is required to bring all transceivers to one potential level.

BIAS resistor (RBIAS) (also called balancing or polarization)

The voltage level on the bus line is not defined when no transceiver is active, so it is necessary to pull D1 and D0 to the bus-idle-state ($D1 = 1, D0 = 0$).

Termination resistor (RT)

Must be installed at each end of the bus. They must suppress reflections of the data signal at the end of the data line.

Shield

The cable which is used should be shielded to protect the data line against outside disturbances.

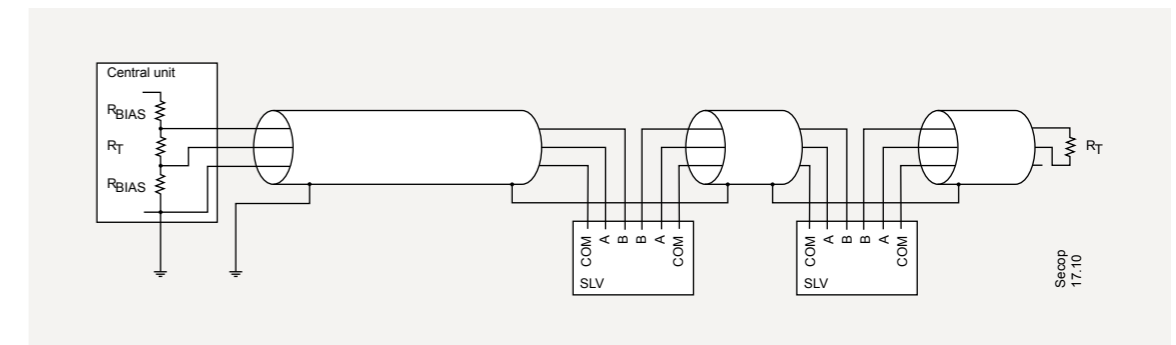

Equivalent circuit diagram of the Modbus

Recommended electrical equipment:

The controller is designed to use standard network equipment with RJ-45 CAT5 cables and RJ-45 Y-distributors with a 1:1 pin connection. Make sure that the adapter is a shielded type, otherwise the shield will end behind the first Y-connector. With these parts it is very easy to build up the connections between the controller and bus master. Screw terminals and D-shell 9 are also accepted by the standard and could be used, while the controller is designed to support RJ-45.

Please note: Connection of a crossed cable in a 2-wire Modbus system can cause damage.

7.2. Installation

Cable length

With the recommended usage of RJ-45 and CAT-5 cables, a maximum cable length of 600 m can be reached without additional equipment. A cable length of 1,000 m is possible when choosing other cables, but this solution is normally much more expensive in material and installation. The possible cable length depends on the installation quality and type of termination.

Knot count

The knot count depends on the properties of each connected knot and from the quality of the installation.

At least 32 knots are always guaranteed (without repeater) by the specification, but this requires a proper installation. The properties of the knots are defined by their driver capabilities. There are "full", "1/2", "1/4", and "1/8" available on the market. Full transceivers make 32 knots possible. With "1/2" transceivers up to 64 knots are possible and so on. The weakest transceiver holds the maximum possible knot count. When there is only one "full" transceiver in a bunch of "1/4" transceivers the bus is limited to max 32 units. With "1/8" transceivers it is possible to build a network with up to 256 knots, but this requires good network equipment and a proper installation. With more than 32 knots a repeater could be necessary. When more than 31 controllers are used, a repeater is recommended.

Data rate

The controller is supporting a data rate of 9.6 kbit and 19.2 kbit, 19.2 kbit being the default. Further data rates are not supported.

Wiring

The wiring is a one-to-one connection of the used lines, so all D1 lines are connected to one wire, similarly D0 lines and all commons (see also "Pin Assignments"). D1 and D0 must be together in a twisted pair. This is guaranteed with the recommended equipment. The recommended topology is the "bus" structure with passive taps and a derivation cable to the controller. The standard allows a maximum length for passive taps of 20 m and with multi-port taps of 40 m, but the derivation cables should be as short as possible to reduce problems and increase performance.

This solution is the simplest way to install a cheap network with low risk of error. The recommended equipment is the standard parts for computer networks.

Polarization

The communication with the controllers requires line polarization, the controller as a passive device isn't prepared to do this. Both bus lines must be pulled to a stable state which represent its logical idle state D1 = 1 (type 5 V) and D0 = 0 (COM/PE). The specification requires a value of 450 Ω to 650 Ω for each. These balancing resistors must only be installed once on the bus. Often the master will have these resistors built in; otherwise it should be close to the master.

Termination

The specification requires a resistor of 150 Ω (0.5 W) at either end or a 120 Ω (0.25 W) resistor with a 1nF (25 V) capacitor in series between D1 and D0. The bus termination is a very important point when the knot count is high and/or the cable is very long. The termination must be placed on both ends of the communication line.

It is possible that other Modbus equipment has built in termination, these terminators must be disabled (these additional terminators will increase the bus load and limit the possible length of the bus and knot count). Only the terminators at the ends of the Modbus are allowed. The general rule is to reduce the resistance or to decrease the current. A reduction of the current by using a RC terminator instead of a simple resistor is one of the safest ways. Please note, it's possible that the terminations inside the bus master only have a resistor. In these cases it is recommended to disable the internal termination and add a RC terminator external. This solution has the benefit of the lowest power consumption in bus idle state.

A bus configuration with a normal resistor termination should only be used if there are only a few knots and a relative short bus.

Common line

The common line is required to bring together all transceivers which are connected to the bus. This line should have only one direct connection to PE, which should be close to the bus master. In some cases the master has a common port which has a direct PE connection. If this internal PE connection is optional a direct connection to a PE rail would be the better choice. Further PE connections (such as contact to the chase of the fridge) will establish loops which could have influence on the communication quality. Non isolated bus knots are in general not allowed.

Shield

The cables used must be shielded. The requirements are the same as for the common pin. The shield must be connected to PE at only one point. Best case would be the same point as the common (when common is directly connected to PE), but the common and shield should have no further connection to each other. A connection to PE via a pigtail will decrease the performance; a metal cable clamp on a PE rail is the preferable solution. All cables and connectors should be shielded. The shield of the female connector must be connected to the other female connectors in the Y-adaptors or in the D-shells.

Pin assignments

If an RJ-45 or a 9-pin D-shell connector is used for a standard Modbus device, the pin outs hereafter must be respected for every implemented circuit.

2W-Modbus RJ45 and 9-Pin D-Shell Pinouts						
Pin on RJ45	Pin on D9-Shell	Level of Requirement	IDv Circuit	ITr Circuit	EIA/TIA 485 Name	Description for IDv
3	3	Optional	PMC	-	-	Port Mode Control
4	5	Required	Df	D1	B/B'	Transceiver terminal 1.V1 voltage [V1→V0 for binary 1 (Off) stage]
5	9	Required	D0	D0	A/A'	Transceiver terminal 0, V0 voltage [V0 → V1 for binary 0 (ON) state]
7	2	Recommended	VP	-	-	Positive 5...24 V D.C. Power supply
8	1	Required	Common	Common	C/C'	Signal and power supply common

Pin Assignment for RJ-45 and D-Sub

RJ-45 Jack for Single-Pair Communication

Device Side – Female Connector

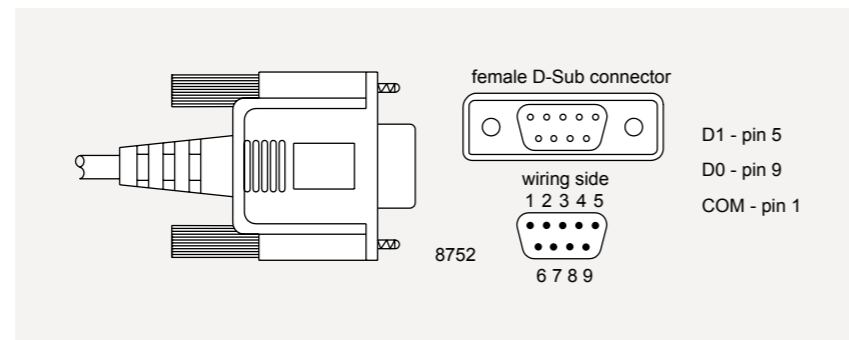
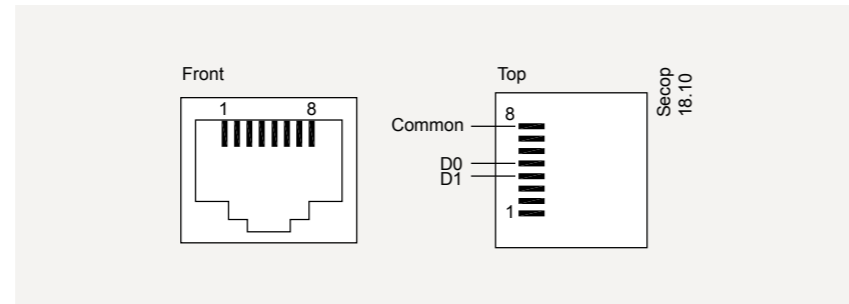

The following systems can be connected to the Modbus:

→ ADAP-KOOL®- Danfoss supermarket monitoring system

→ Master functions:

- Night offset
- Blind
- Clock synchronization
- Alarm limit offset
- Dew point control

→ Tool4Cool® – Secop tool for adjusting and servicing of variable speed compressor products

The possibility of errors in the installation is very limited when using standard computer network equipment for the Modbus. A safely running bus is ensured with BIAS resistors (inside the bus masters) and the correct termination. Bigger networks require a proper installation of common lines and shielded cables.

For more information please refer to "Technical Resources" on: www.modbus.org

TECHNICAL DATA

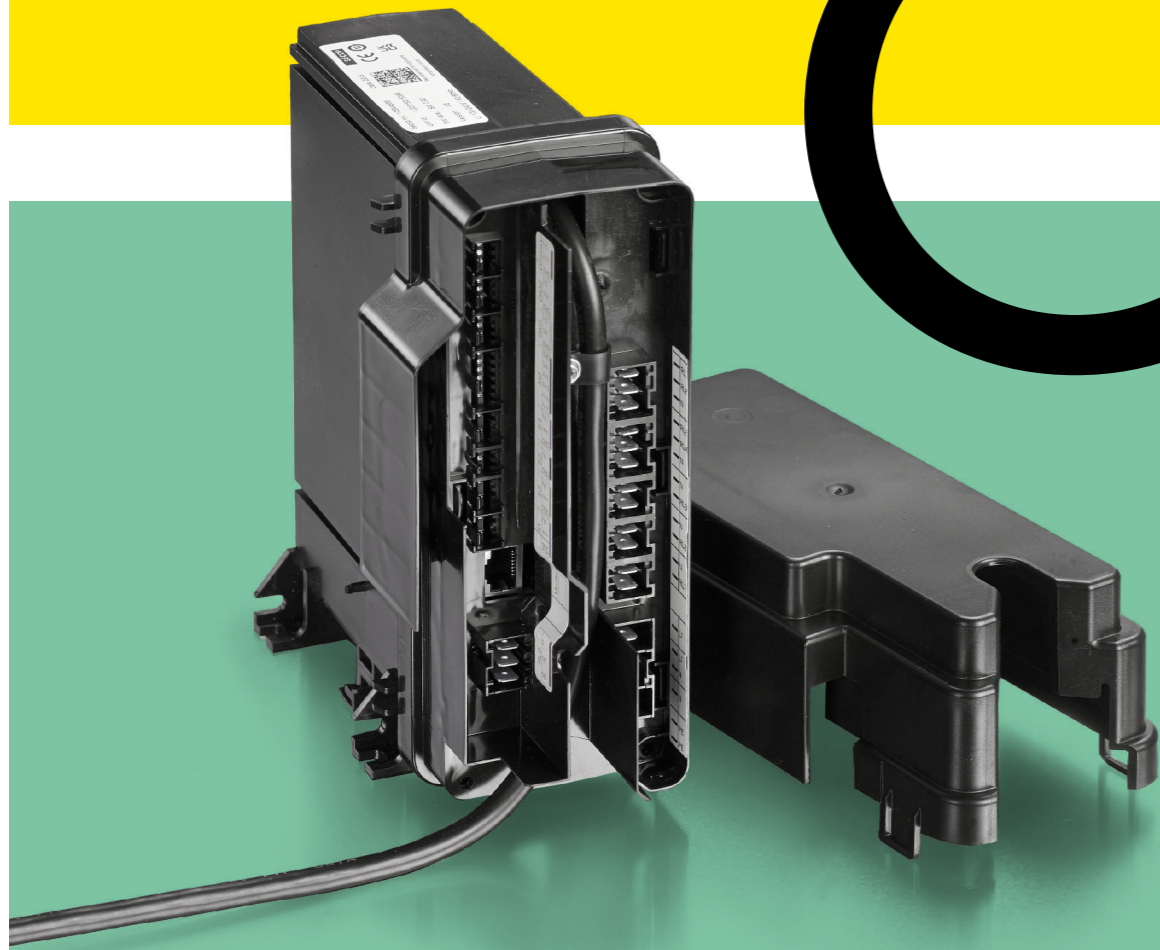
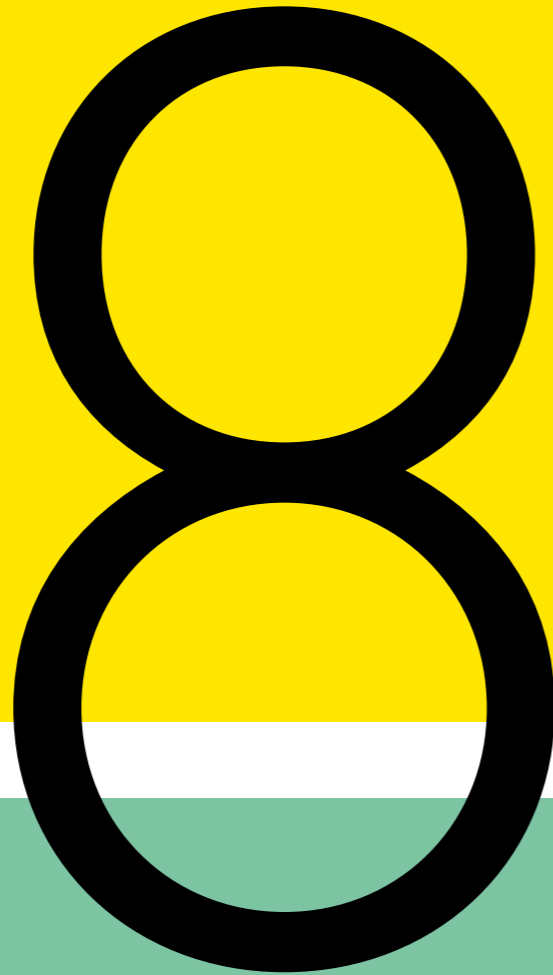

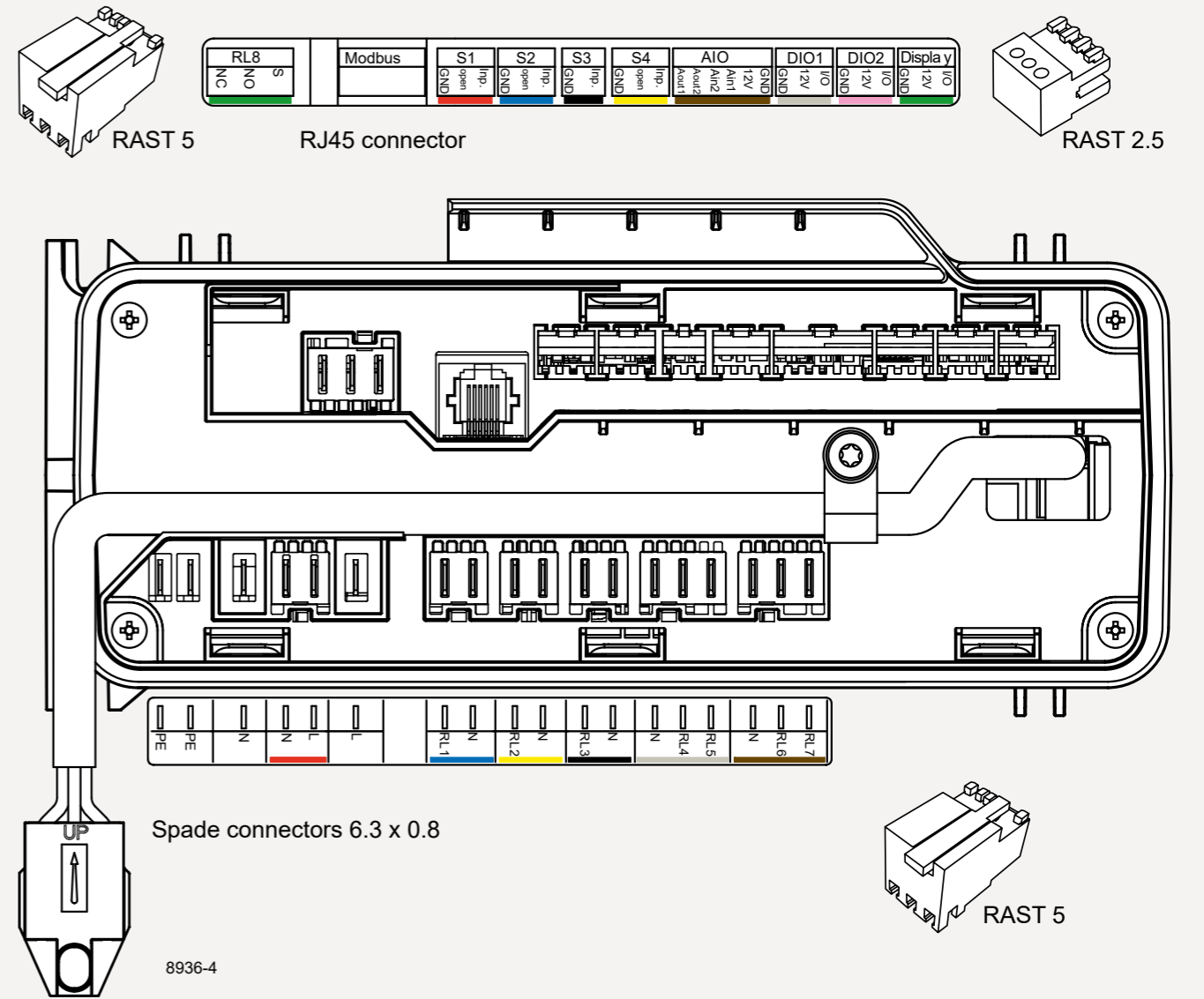

8.1. Controller Connection

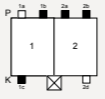

8.1.1. Input Power

Name	Pin	Type	Specification
Protective Earth	PE	2x Faston 6.3 mm × 0.8 mm	
	PE		
Neutral	N	Faston 6.3 mm × 0.8 mm	
Neutral and Phase	N	2-Pole RAST 5 connector The coding scheme shows position of keying and locking latches. Black means the key is present.	
	L1		
Phase	L1	Faston 6.3 mm × 0.8 mm	16A Fuse

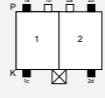
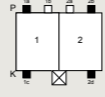
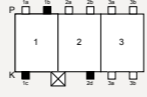
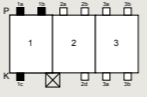
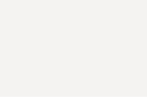
8.1.2. Relays

Name	Pin	Type	Specification
RL 1	1	Live switched, N.O.	
	2	Neutral	
RL 2	1	Live switched, N.O.	
	2	Neutral	
RL 3	1	Live switched, N.O.	
	2	Neutral	
RL 4 RL 5	1	RL4 output, Live switched, N.O.	
	2	RL5 output, Live switched, N.O.	
	3	Neutral	
RL 6 RL 7	1	RL6 output, Live switched, N.O.	
	2	RL7 output, Live switched, N.O.	
	3	Neutral	
RL 8	1	N.C.	
	2	N.O.	
	3	Base pin	

8.1.3. Modbus

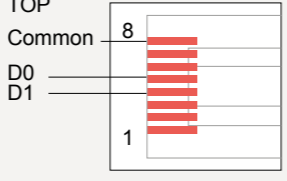
Name	Pin	Type	Specification
MODBUS RTU	4/D1		Standard: IEA485
	5/D0		Maximum nodes: With RC termination 100
	8/Common		With Resistor termination up to 32
			Cable max. length: 1,000 m
			Maximum stub no. and length 30/1 m
			Termination: Resistor 150 Ω (30 nodes)
			Recommended RC series: 120 Ω, 1nF
			Installation must be in accordance to "standard modbus.org" with RJ45 plugs and CAT5

8.1.4. Temperature Sensors

Name	Pin	Type	Specification
S1	1	GND	Measurement range: -55 to 85°C
	2	Not connected	
	3	Analogue input	
S2	1	GND	Sensor Characteristics: Nominal Resistance at 0°C: 16.3 kΩ Nominal Resistance at 25°C: 5.0 kΩ
	2	Not connected	
	3	Analogue input	
S3	1	GND	Nominal resistance tolerance: ±2% B value: 3980 K
	2	Analogue input	
S4	1	GND	B value condition: B25/100 B value tolerance: ±1.5%
	2	Not Connected	
	3	Analogue input	

8.1.5. Analog and Digital IOs

Name	Pin	Type	Specification
DIO1	1	GND	10-12 V DC
	2	V supply	
	3	Digital I/O	
DIO2	1	GND	10-12 V DC
	2	V supply	
	3	Digital I/O	
Display (DIO3)	1	GND	10-12V DC
	2	V supply	
	3	Single-wire com signal (SWI)	
AIO1	1	GND	10-12 V DC
	2	V supply	
	3	Analog/Digital input	
	4	Analog/Digital input	
	5	Analog output	
	6	Analog output	
			Internal pull-up resistor to V supply 10 kΩ Signal voltage range: 5-12 Vpp Max current sourcing: 20 mA Half-duplex single wire, baud rate: 1200-9600
			Analog signal range: 0-5 V Input impedance → 10 kΩ
			Not enabled yet

Find more details in chapter: Hardware Interface description/Installation

8.2. Controller Data

	Electronic Unit	105N4866
Power supply	Nominal voltage	100–240 V AC
	Minimum operating voltage	80 V AC
	Minimum starting voltage	180 V AC
	Maximum voltage	270 V AC
	Frequency	50–60 Hz
	Max power input	1,000 W
	Power factor corrector	Yes, active, PF ≥ 0.95
	Motor cable length	680±20 mm/26.0–27.6 in.
Environment	IP class	IP43
	Humidity	30–90% rH
	Maximum operating temperature	50 °C / 120°F
	Minimum operating temperature	0°C / 32°F
	Storage temperature	-30 to 70°C / -22°F to 158°F
Approvals/Safety	Compressor protection	Software protection + internal in compressor
	Safety approval	UL60335-2-34 with Annex AA EN60335-2-34 with Annex AA CB, CCC
	EMC conformity	According to 2014/35/EC
	RoHs Conformity	2011/65/EU
Speed-Control	Frequency input	5–12 V, max. 8 mA, 0–200 Hz Galvanic isolated, short and reverse protected
	AEO Thermostat input (Lsw)	80–264 V AC, non-isolated
	AEO Defrost input (Def)	80–264 V AC, non-isolated
	RX/TX interface (DWI)	5–12 V, max. 8 mA, 600 baud galvanic isolated
	Single-wire interface (SWI)	Modbus communication port, 9600 baud galvanic isolated
Relays	Max. individual load RL1–RL7	8A resistive, 30,000 cycles
	Max. total load RL1–RL7	16A resistive
	Max. load RL8	3A resistive

8.3. Compressor data

	NLV8.0CN/NLV 10CN/NLV12.6CN	Multiple Voltage	Standard	
Compressor	Application	LBP/MBP	LBP/MBP	
	Evaporating temperature	°C [°F]	-40 to 7.2 [-40 to 45]	-40 to 7.2 [-40 to 45]
	Voltage range/frequency	V/Hz	90–270/50/60	180–270/50/60
	Speed range	rpm	2000–4500	2000–4500



**8.4.
Capacity and
Performance Data
NLV8.0CN**

Performance Data ASHRAE LBP (115/220 V, 50/60 Hz • fan cooling) @ -23.3°C [-10°F] evaporating temperature				
Speed	rpm	2000	3000	4500
Cooling capacity	W	259	409	620
	BTU/h	885	1397	2119
Power consumption	W	147	220	341
COP	W/W	1.76	1.86	1.82
EER	BTU/Wh	6.02	6.35	6.22

Test conditions Condensing temp.: 54.4°C [130°F] | Suction gas temp.: 32.2°C [90°F]
Ambient temp.: 32.2°C [90°F] | Liquid temp.: 32.2°C [90°F]

Performance Data ASHRAE MBP (115/220 V, 50/60 Hz • fan cooling) @ -6.7°C [20°F] evaporating temperature				
Speed	rpm	2000	3000	4500
Cooling capacity	W	481	723	1097
	BTU/h	1644	2470	3745
Power consumption	W	205	303	470
COP	W/W	2.35	2.39	2.34
EER	BTU/Wh	8.04	8.16	7.97

Test conditions Condensing temp.: 54.4°C [130°F] | Suction gas temp.: 35°C [95°F]
Ambient temp.: 32.2°C [90°F] | Liquid temp.: 46.1°C [115°F]

**8.5.
Capacity and
Performance Data
NLV10CN**

Performance Data ASHRAE LBP (115/220 V, 50/60 Hz • fan cooling) @ -23.3°C [-10°F] evaporating temperature				
Speed	rpm	2000	3000	4500
Cooling capacity	W	340	529	797
	BTU/h	1162	1808	2721
Power consumption	W	194	291	441
COP	W/W	1.76	1.82	1.81
EER	BTU/Wh	6.00	6.22	6.18

Test conditions Condensing temp.: 54.4°C [130°F] | Suction gas temp.: 32.2°C [90°F]
Ambient temp.: 32.2°C [90°F] | Liquid temp.: 32.2°C [90°F]

Performance Data ASHRAE MBP (115/220 V, 50/60 Hz • fan cooling) @ -6.7°C [20°F] evaporating temperature				
Speed	rpm	2000	3000	4500
Cooling capacity	W	678	1046	1578
	BTU/h	2074	3199	4826
Power consumption	W	269	408	627
COP	W/W	2.26	2.30	2.25
EER	BTU/Wh	7.70	7.85	7.69

Test conditions Condensing temp.: 54.4°C [130°F] | Suction gas temp.: 35°C [95°F]
Ambient temp.: 32.2°C [90°F] | Liquid temp.: 46.1°C [115°F]

**8.6.
Capacity and
Performance
Data NLV12.6CN**

Performance Data ASHRAE LBP (115/220 V, 50/60 Hz • fan cooling) @ -23.3°C [-10°F] evaporating temperature				
Speed	rpm	2000	3000	4500
Cooling capacity	W	393	606	916
	BTU/h	1497	2308	3490
Power consumption	W	249	371	567
COP	W/W	1.76	1.82	1.80
EER	BTU/Wh	6.02	6.22	6.16

Test conditions Condensing temp.: 54.4°C [130°F] | Suction gas temp.: 32.2°C [90°F]
Ambient temp.: 32.2°C [90°F] | Liquid temp.: 32.2°C [90°F]

Performance Data ASHRAE MBP (115/220 V, 50/60 Hz • fan cooling) @ -6.7°C [20°F] evaporating temperature				
Speed	rpm	2000	3000	4500
Cooling capacity	W	766	1189	1772
	BTU/h	2618	4062	6053
Power consumption	W	351	535	835
COP	W/W	2.18	2.22	2.12
EER	BTU/Wh	7.45	7.60	7.25

Test conditions Condensing temp.: 54.4°C [130°F] | Suction gas temp.: 35°C [95°F]
Ambient temp.: 32.2°C [90°F] | Liquid temp.: 46.1°C [115°F]









ORDERING



10.1. Secop Order

	Item	Code No.	Comment
Controller	Extendend (XT) electronic control-ler (°CCD), Multi Voltage, 100-240 V AC	105N4866	Single unit
		105N4867	Industrial pack (8 units)
Compressor, Accessories	NLV12.6CN compressor	105H7365	Compressor w. metric connectors
		105H7366	Compressor w. inch connectors
	NLV10CN compressor	105H7065	Compressor w. metric connectors
		105H7066	Compressor w. inch connectors
	NLV8.0CN compressor	105H7865	Compressor w. metric connectors
		105H7866	Compressor w. inch connectors
	Cover for compressor	103N2008	
	Bolt joint for one compressor	118-1917	
	Bolt joint in quantities	118-1918	
	Snap-on in quantities	118-1919	
RAST 5 connector 1 pcs	105N9563	Lumberg 3623-02	
RAST 2.5 connector 1 pcs	105B4232	Lumberg 3521-03	
Displays	Display CRA 200 (width: 67 mm, height: 25 mm, depth: 13 mm)	105N9592	Only PCB and display/No housing 3. LED-based local display, 3 push buttons
	Display CRA 172 (width: 74 mm, height: 34 mm, depth: 22 mm)	105N9512	3. LED-based local display, 3 push buttons
	Display CRA 162 (width: 74 mm, height: 34 mm, depth: 22 mm)	105N9510	3. LED based local display, 3 push buttons
	Display cable, short (length: 600 mm)	105N9509	3 wires isolated for display connection
	Display cable, long (length: 2000 mm)	105N9511	3 wires isolated for display connection
Temperature Sensor	NTC temperature sensor S1	105N9626	Length: 3,000 mm, color: red
	NTC temperature sensor S1	105N9625	Length: 2,000 mm, color: red
	NTC temperature sensor S1	105N9624	Length: 1,000 mm, color: red
	NTC temperature sensor S1	105N9623	Length: 500 mm, color: red
	NTC temperature sensor S2	105N9630	Length: 3,000 mm, color: blue
	NTC temperature sensor S2	105N9629	Length: 2,000 mm, color: blue
	NTC temperature sensor S2	105N9628	Length: 1,000 mm, color: blue
	NTC temperature sensor S2	105N9627	Length: 500 mm, color: blue
	NTC temperature sensor S4	105N9634	Length: 3,000 mm, color: yellow
	NTC temperature sensor S4	105N9633	Length: 2,000 mm, color: yellow
	NTC temperature sensor S4	105N9632	Length: 1,000 mm, color: yellow
	NTC temperature sensor S4	105N9631	Length: 500 mm, color: yellow
	NTC temperature sensor S3	-	
Literature	Compressor data sheet	https://www.secop.com/products/product-selector/data-sheet-search	
	°CCD interface description	On request	
	Tool4Cool® Operating Instructions	www.secop.com/tool4cool	

10.2.
Third Party Order

	Item	Code No.	Description
AIO/DIO	Connector for DIO	Not available at Secop	3-pole RAST-2.5 connector
	Connector for AIO	Not available at Secop	6-pole RAST-2.5 connector
Mains and relay connector	Connector for mains	105N9563	2-pole RAST-5 connector 
	Connector for RL1	Coded connectors are not available at Secop.	2-pole RAST-5 connector 
	Connector for RL2	Connector with coding can be ordered directly at the manufacturer. For example: Lumberg, Tyco, Stocko, and Molex	2-pole RAST-5 connector 
	Connector for RL3	(You will find a selection of series in the table below)	2-pole RAST-5 connector 
	Connector for RL4 and 5	Please find the coding in chapter 2 Connection of power outputs	3-pole RAST-5 connector 
	Connector for RL6 and 7		3-pole RAST-5 connector 
	Connector for RL8	All connections can also be done via Faston 6.3 x 0.8 mm connectors	3-pole RAST-5 connector 
Lab tool	Gateway	Not available at Secop	Can be done with RS485 to USB converter Take a RJ45 cable, cut it and then connect "blue" to TDB(+), "blue/white" to TDA(-) and "brown and shield" to GND.
	RJ45 Ethernet patch cable	Not available at Secop	Connection between NLV controller and gateway with DSUB-9/RJ45 adaptor
	Tool4Cool® LabEdition	Free of charge	https://www.secop.com/solutions/application-show/variable-speed-drive-software-tool4cool

Manufacturer	Rast 2.5	Rast 5 (IDC)	Crimp	Screw terminals
Lumberg	3521	3623		
Stocko	Eco-Tronic	ECO-Domo NF	ECO-Domo crimp	WIECON 8105
Tyco	Duoplug 2.5	Mono-Shape Tab	STD-Timer (crimp)	
Molex	Appli-Mate RAST 2.5	Appli-Mate RAST 5	Rast 5 crimp	

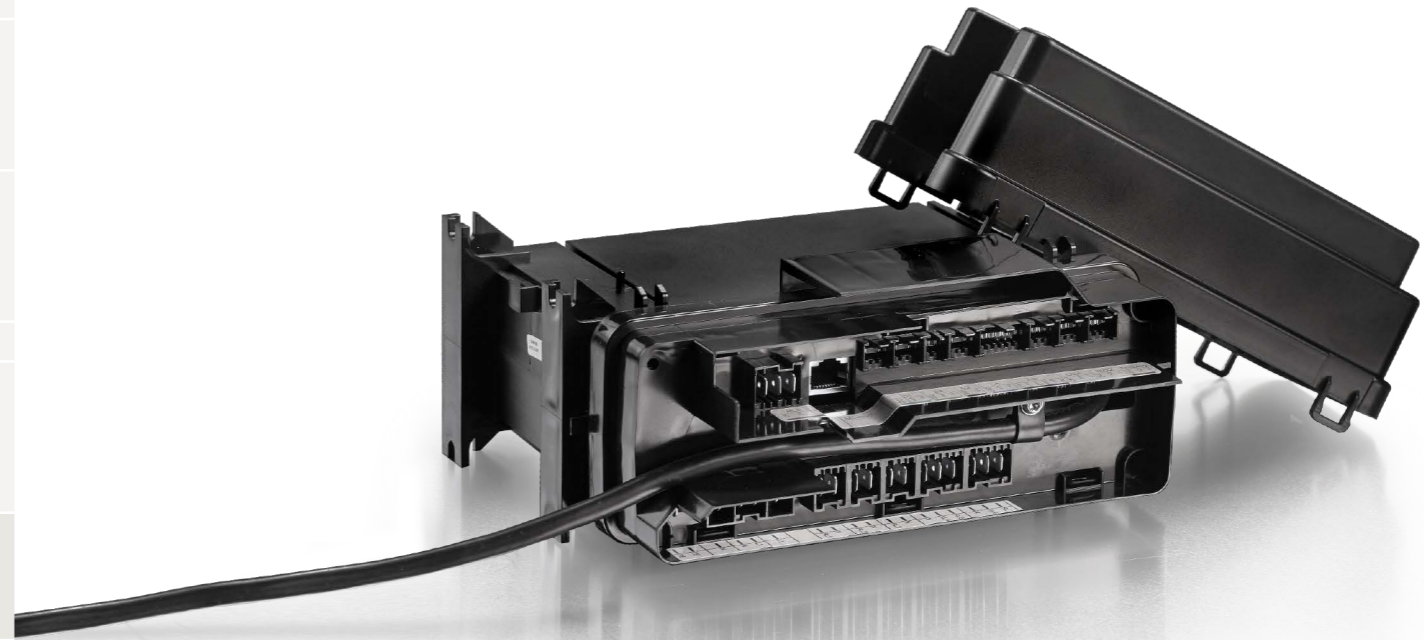

NLV WITH INTELLIGENT MULTIPLE VOLTAGE CONTROLLER

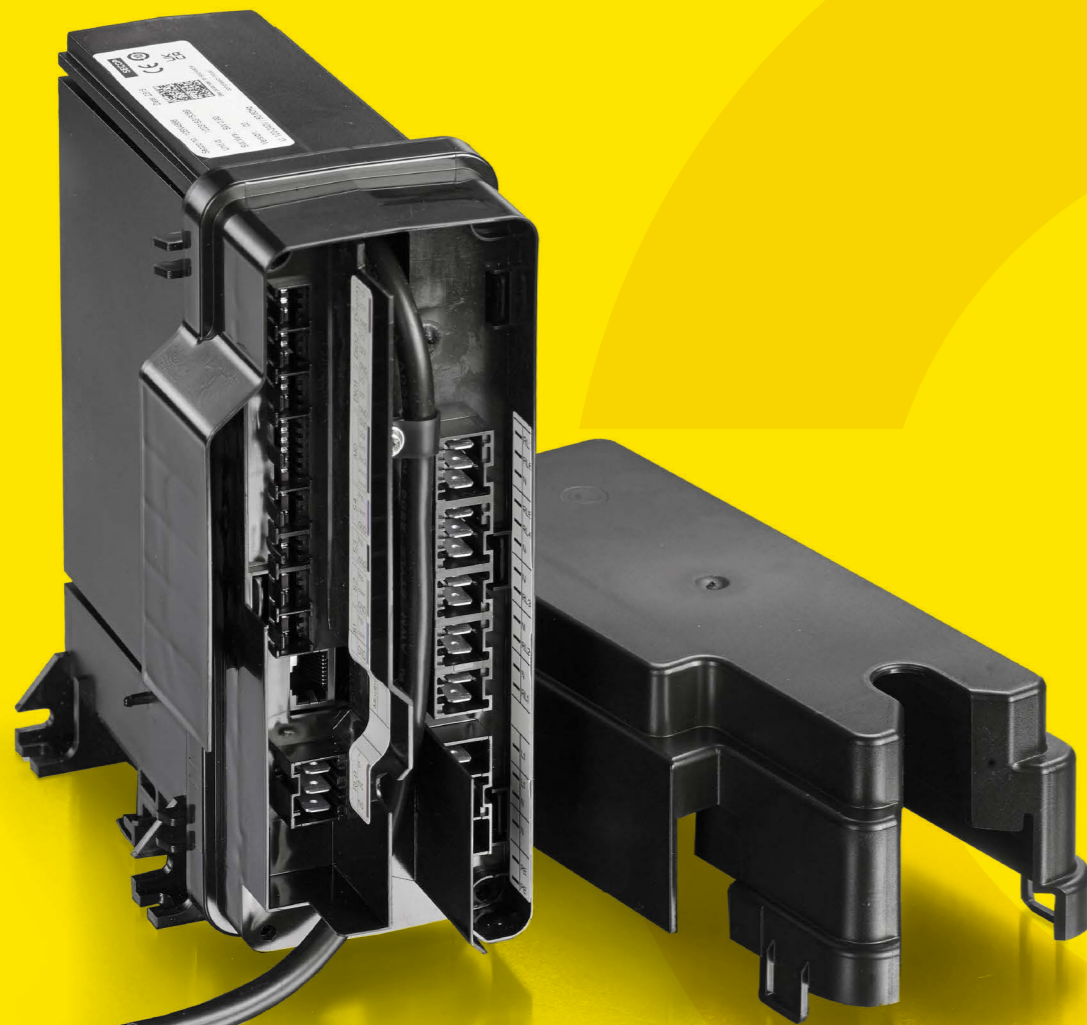

Secop's variable speed NLV-CN propane compressor solution provides perfect cooling efficiency, tailor-made features, and easy integration within a single unit while ensuring considerable energy savings.

It is the right choice if you are looking for a green solution using the environmentally-friendly refrigerant propane (R290) with a low global warming potential (GWP 3).

The new XT °CCD controller features a high IP43 protection class and easy integration by using speed control through Adaptive Energy Optimization (AEO), frequency signal or serial communication.

The controller also provides a high starting torque and can start against a differential pressure.

Only the variable-speed design can achieve energy savings of up to 40% when compared to fixed speed compressors in on/off operation mode.

The new 105N4866 °CCD controller can be used for all voltages and frequencies globally thanks to its wide operating voltage range.



SECOP GROUP: AROUND THE WORLD

SECOP

12

international
partners for
advanced
developments

33

laboratories
located in Germany,
Slovakia, China,
U.S.A., and Turkey

150+

R&D engineers
and technicians

400+

patents globally

50+

countries with
customer support



Secop is the expert for advanced hermetic compressor technologies and cooling solutions in commercial refrigeration. We develop high performance stationary and mobile cooling solutions for leading international commercial refrigeration manufacturers and are the first choice when it comes to leading hermetic compressors and electronic controls for refrigeration solutions for light commercial and DC-powered applications.

Secop was formerly known as Danfoss Compressors and is one of the founding fathers of modern compressor technology with years of experience that goes back to the beginning of the 1950s.

-  **Flensburg:** Sales and R&D
-  **Zlaté Moravce:** R&D, Logistics, and Manufacturing
-  **Turin:** Sales
-  **Tianjin:** Sales, R&D, Logistics, and Manufacturing
-  **Atlanta:** Sales and Logistics



**Stationary
Cooling**



**Mobile
Cooling**



**Medical
Cooling**



Secop GmbH · Lise-Meitner-Str. 29 · 24941 Flensburg, Germany · Tel: +49 461 4941 0 · www.secop.com

Secop accepts no responsibility for possible errors in catalogs, brochures, and other printed material. Secop reserves the right to alter its products without notice. This also applies to products already on order provided that such alterations can be made without subsequential changes being necessary to specifications already agreed. All trademarks in this material are the property of the respective companies. Secop and the Secop logotype are trademarks of Secop GmbH. All rights reserved.

Produced by Secop | June 2026

DES.S.300.M2.02