

## Single Pack NLVE13CN 115-127V 50/60Hz

Single pack code number: **195B4831**

Position	Title	Code	Amount
1	Compressor NLVE13CN	105H7374	1
2	Electronic unit NLVE	105N4101	1
3	Cover	103N2008	1
4	Bolt joint for one compressor   M6   ø16mm	118-1917	1

**Secop GmbH** • Lise-Meitner-Straße 29 • 24941 Flensburg, Germany • Tel: +49 461 4941 0 • [www.secop.com](http://www.secop.com)

Secop accepts no responsibility for possible errors in catalogs, brochures, and other printed material. Secop reserves the right to alter its products without notice. This also applies to products already on order provided that such alterations can be made without subsequent changes being necessary to specifications already agreed. All trademarks in this material are the property of the respective companies. Secop and the Secop logotype are trademarks of Secop GmbH. All rights reserved.

## Model

Designation	<b>NLVE13CN</b>	Sales code:	<b>105H7374</b>
-------------	-----------------	-------------	-----------------

## Compressor design

Oil type	Polyolester	Refrigerant(s)	<b>R290</b>
Oil viscosity	32cSt	Displacement	12,55cm <sup>3</sup> / 0,77cu.in
Oil quantity	300cm <sup>3</sup> / 10,1fl.oz	Compressors on pallet	80
Refr. charge - tech. limit	300g / 10,6oz		
Free gas volume comp.	2360cm <sup>3</sup> / 79,8fl.oz		
Weight	10,8kg / 23,8lbs		
Motor protection	2# internal		
Winding resist. ph. to ph.	3,55Ω (at 25°C)		
Max. winding temp.	125°C / 257°F		
Max. discharge temp.	130°C / 266°F		



## General - Configurations and Applications with NLVE13CN and Controller

### Conf. 1

Sales code single pack:	105N4100
Sales code industry pack:	105N4101
Power supply (nominal)	115–127V,50/60Hz
Approvals	UL
Refrigerant	R290
Number of phases	1~AC
Application	L+MBP
Starting torque	HST
Hot gas defrost	OK
Long interval pull down	OK
System cooling	Fan cooling 3m/s
Note	- / -

## Controller functions

### Conf. 1

Protection	Mechanic
Max output power	1000W
No of relays	0
Hot gas defrost	yes
AEO speed setting	yes
Serial com, (Modbus)	-
DWI / Frequency input	yes
Note	

## Model

Designation **NLVE13CN**

Sales code: **105H7374**

## Compressor dimensions

<b>Housing</b>	A Height	203mm / 7,99in
	B Height	197mm / 7,76in
	C Length shell	205mm / 8,07in
	D Length w. cover	252mm / 9,92in
	E Width	166mm / 6,54in

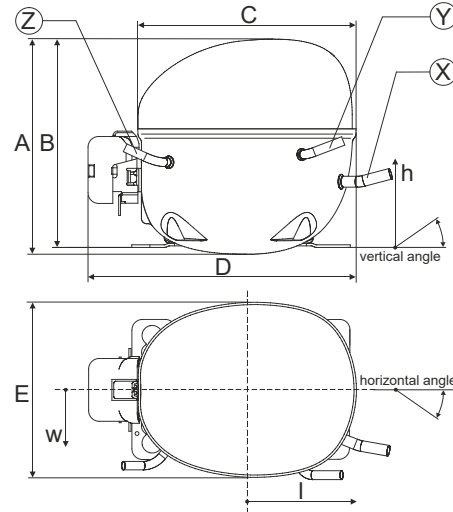

<b>Connectors</b>		<b>Suction</b>	<b>Discharge</b>	<b>Process</b>
		<b>X</b>	<b>Y</b>	<b>Z</b>
Diameter	[mm]	øi 8,11-8,29	øi 6,41-6,59	øi 6,41-6,59
(i:inside, o:outside)	[in]	øi 0,32-0,33	øi 0,25-0,26	øi 0,25-0,26
Material		copper	copper	copper
Horizontal angle	±2°	0°	0°	0°
Vertical angle	±2°	15°	21°	155°
Position l/h/w	[mm]	132/69/57	94/102/81	-109/94/72
	[in]	5,2/2,7/2,2	3,7/4/3,2	-4,3/3,7/2,8
Straight tube l.	[mm]	12	12	12
	[in]	0,5	0,5	0,5

## Compressor fixation

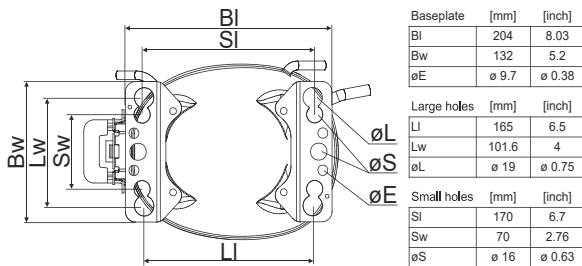

### Bolt joint

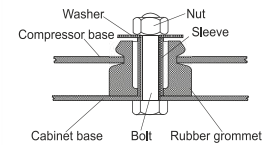

### Snap-on

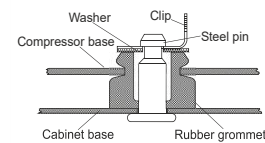

Mounting accessories	one comp.	multi pack
Bolt joint   M6   ø16mm	118-1917	118-1918
Bolt joint   ø1/4"   ø16mm	118-1946	
Bolt joint   ø1/4"   ø19mm	118-1949	
Snap-on   ø7,3   ø16mm	118-1947	118-1919

## Application notes

Provision for PE Grounding is located at the PE Stamp on the compressor  
Semi suction intake without telescope

QR Code and Hyperlink leads to the [Operating Instructions.](#)



## Model

Designation **NLVE13CN** **115-127V,50/60Hz** **Conf. 1** Sales code: **105H7374**

**Controller** **NLV Core Function 115V** **105N4100**

Sales code single pack: 105N4100 (1 units)  
 Sales code industry pack: 105N4101 (8 units)  
 Adaption to compressor: detached  
 Protection class: IP31  
 Weight: 1kg/2,2lbs  
 Voltage nom.: 115-127V,50/60Hz  
 Voltage range: 100-140V  
 Max. current: 8 A  
 LRA (Locked Rotor Amperage): 1,3A  
 Cable length: 680mm  
 Compressor speed range: 2000-4500rpm  
 Housing plastic: UL94-5VA

### Controller dimensions:

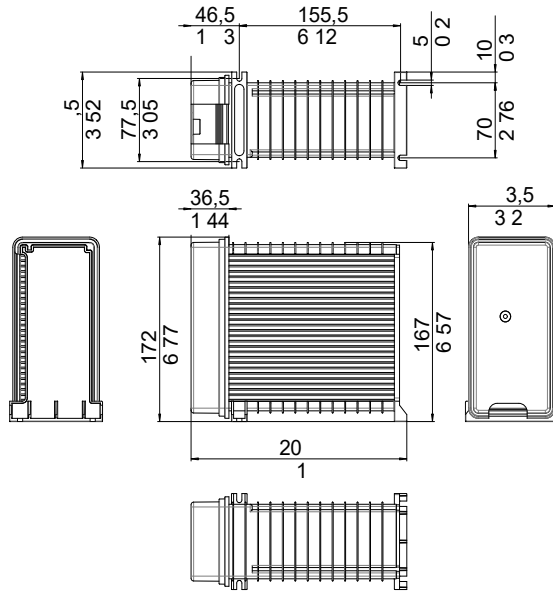

## Operation Limits

### System cooling

#### Ambient/ machineroom temperatures minimum /maximum

Ambient temperature range: 10 - 43°C / 50 - 110°F  
 Machine room temperature range compressor: 10 - 48°C / 50 - 119°F  
 Machine room temperature range controller: 10 - 50°C / 50 - 122°F

**Compressor and Controller Cooling:** Fan cooling 3m/s

Ensure proper airflow of 3 m/s at both compressor and electronic units.

The airflow for the electronics must be directed to the heat sink.

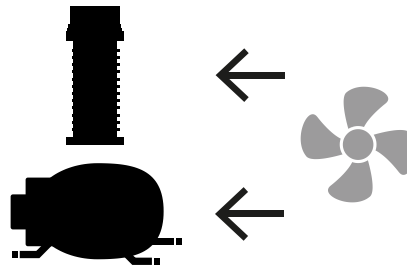

### Operation pressure range

R290

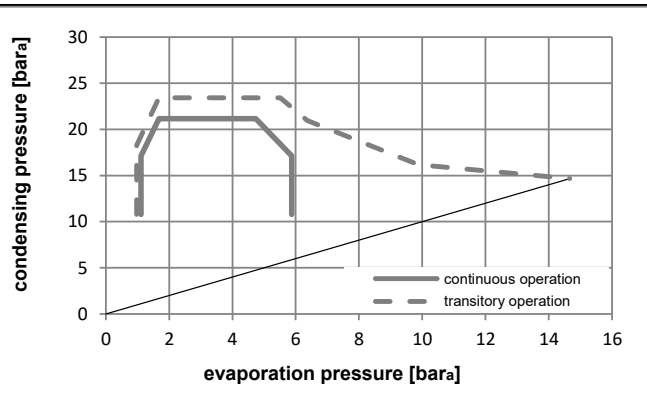
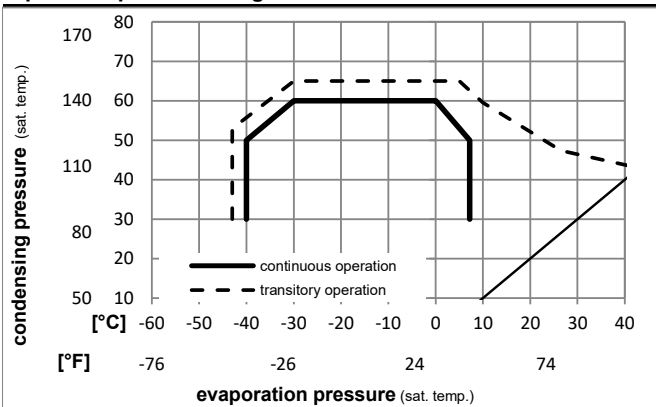

## Model

Designation **NLVE13CN** **115-127V,50/60Hz** **Conf. 1** Sales code: **105H7374**

Controller **NLV Core Function 115V** **105N4100**

## Controller connections

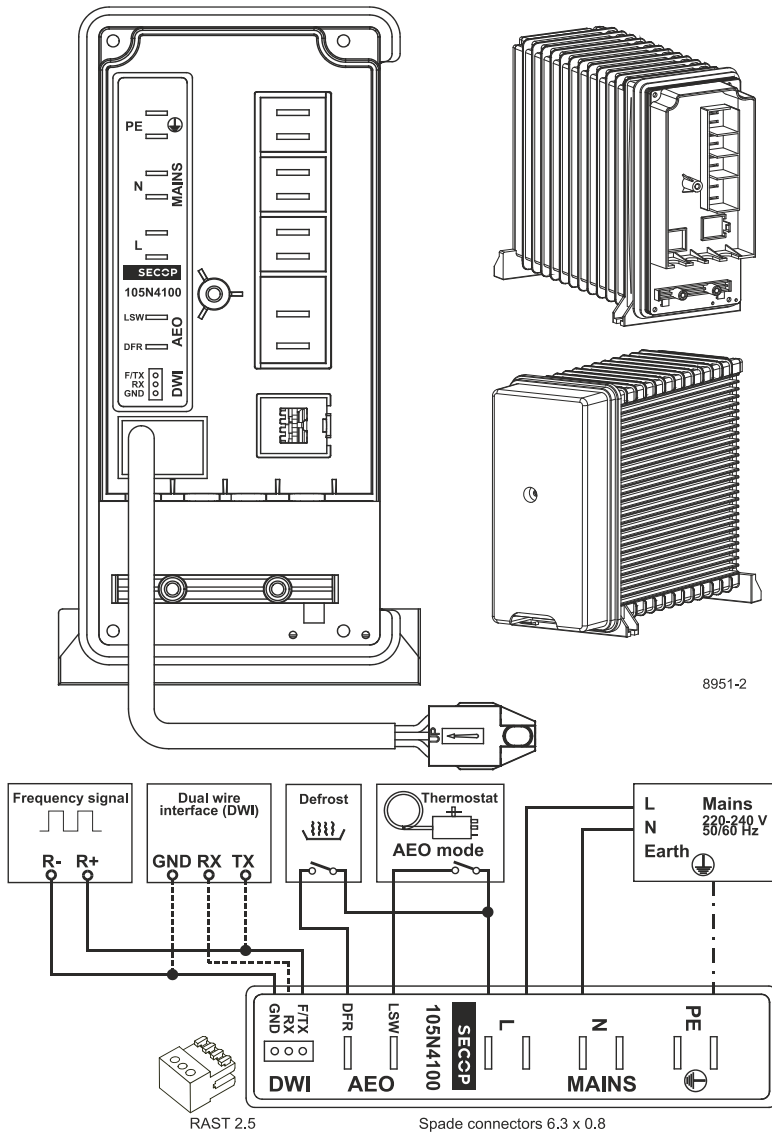

## Accessories (Compressor + Controller) - check operation manual for details

103N2008 plastic cover 1 pcs

### Model

Designation **NLVE13CN** **115-127V,50/60Hz** **Conf. 1** Sales code: **105H7374**

Controller **NLV Core Function 115V** **105N4100**

### Optimization + standard conditions

R290, 115V, 60Hz, Rpm\_N 4500, Fan cooling 3m/s

	Evaporating pressure (saturation temperature)				Condensing pressure (saturation temperature)			Return gas temp.			Liquid temp.			Cooling capacity			COP	EER	Power consumption			ASHRAE LBP			
	pe	pc	RGT	Tliq	[W]	[Btu/h]	[kcal/h]	[W/W]	[Btu/Wh]	[kcal/Wh]	P1	I	m	[W]	[A]	[kg/h]									
[°C]	-23	54	32	32	969,5	3311	834,4	1,69	5,79	1,46	572,1	7,86	9,82												
[°F]	-10	130	90	90																					
[°C]	-25	55	32	55	728,0	2486	626,5	1,32	4,52	1,14	550,6	7,59	9,06												
[°F]	-13	131	90	131																					
[°C]	-35	40	20	40	538,0	1837	463,0	1,40	4,80	1,21	383,1	5,44	6,15												
[°F]	-31	104	68	104																					
[°C]	-7	54	35	46	1688,6	5767	1453,2	2,05	7,01	1,77	822,3	11,08	19,26												
[°F]	20	130	95	115																					
[°C]	-10	55	32	55	1351,2	4615	1162,9	1,75	5,97	1,50	772,7	10,44	17,09												
[°F]	14	131	90	131																					
[°C]	-10	45	20	45	1462,3	4994	1258,5	2,05	7,01	1,77	712,9	9,67	17,95												
[°F]	14	113	68	113																					

### Standard conditions with different RPM

R290, 115V, 60Hz, Fan cooling 3m/s

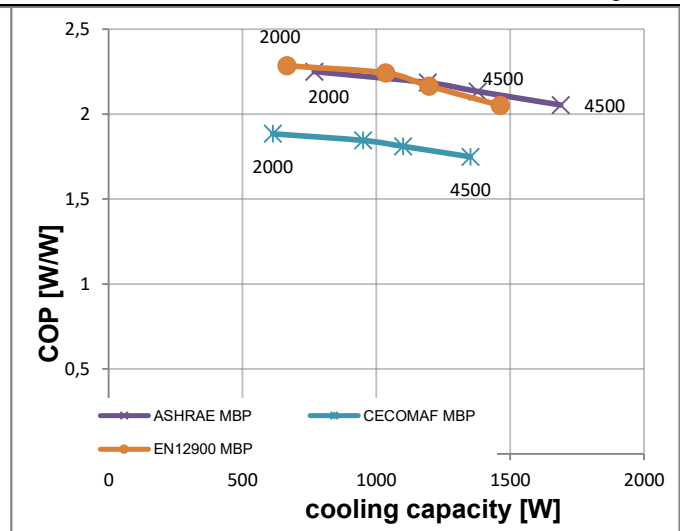
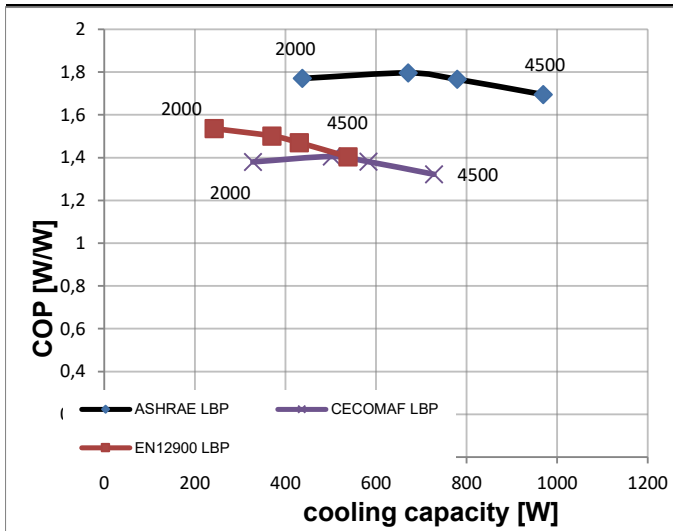

**Test conditions:**

	pe [°C]	pc [°C]	Tliq [°C]	Tsuc [°C]
ASHRAE LBP	-23	54,44	32,22	32,22
CECOMAF LBP	-25	55	55	32
EN12900 LBP	-35	40	40	20

	pe [°C]	pc [°C]	Tliq [°C]	Tsuc [°C]
ASHRAE MBP	-6,66	54,44	46,11	35
CECOMAF MBP	-10	55	55	32
EN12900 MBP	-10	45	45	20

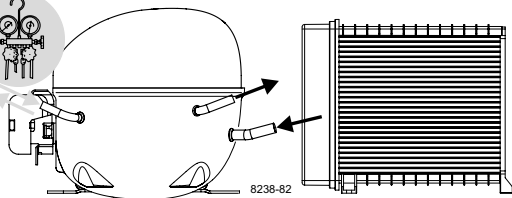
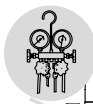

# Instructions

NLVE Compressors  
115-127 V, 50/60 Hz  
105N4100 Controllers

# SECCP

Keep electrical equipment clear from oil, chemicals, and water

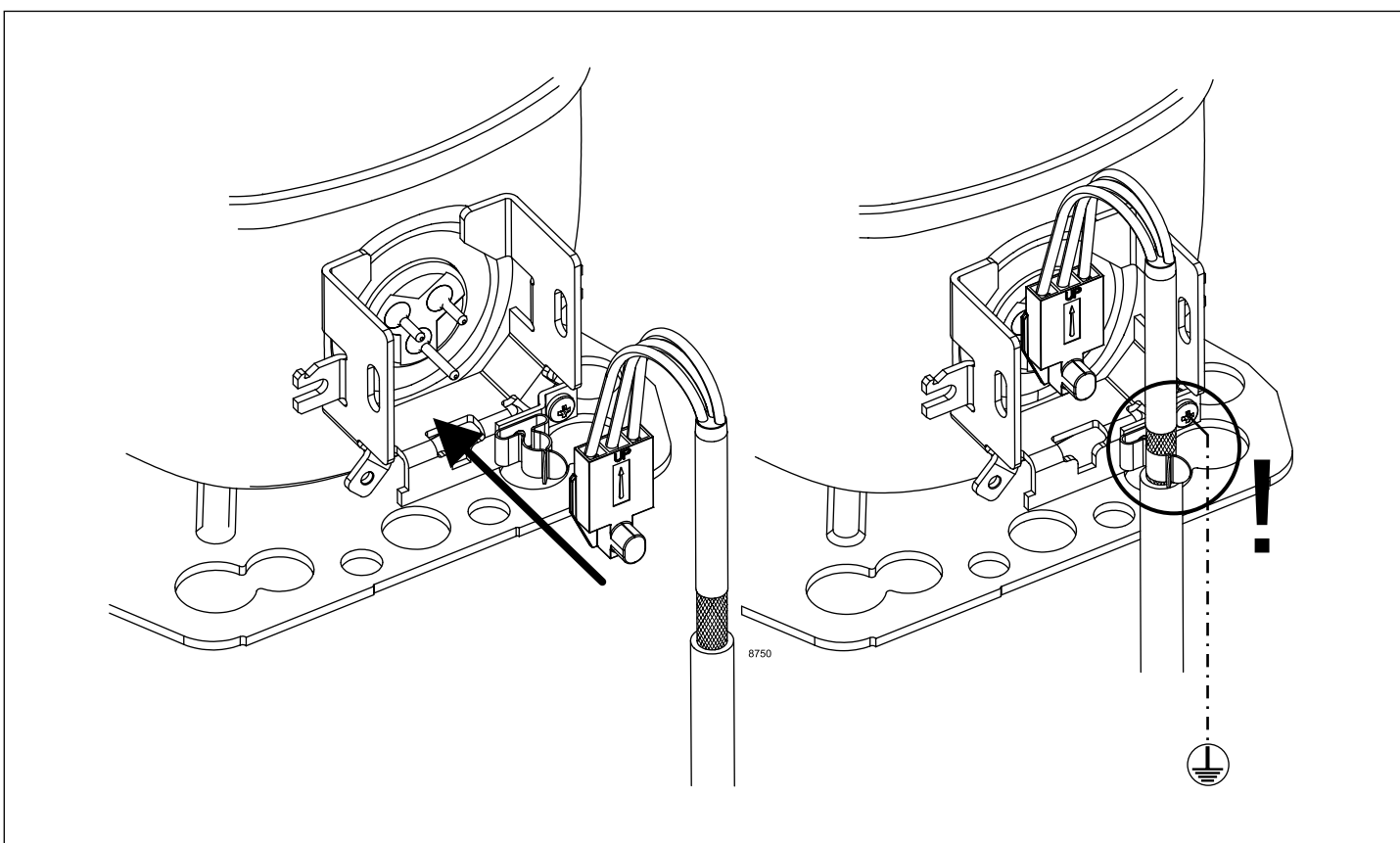
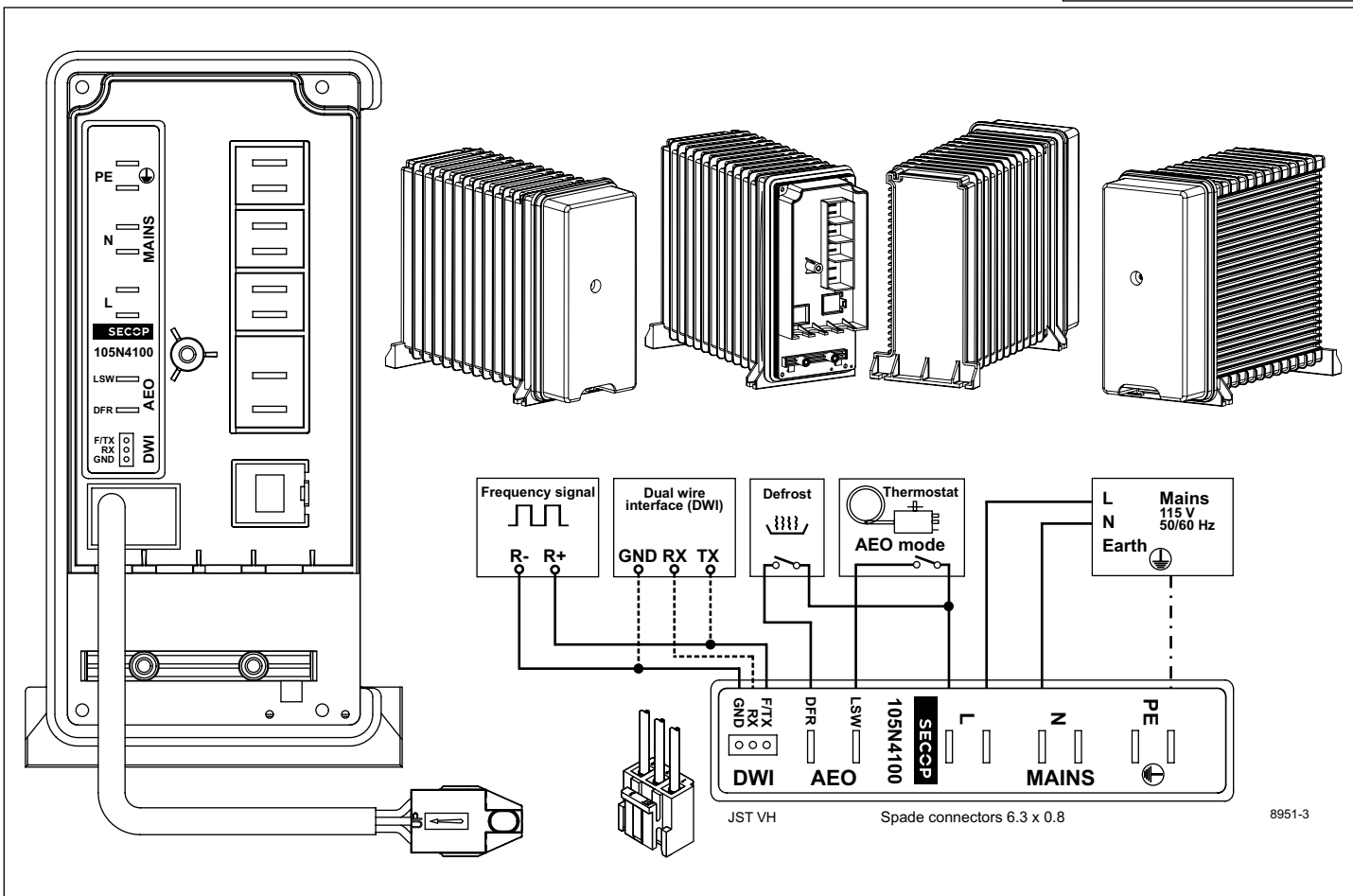

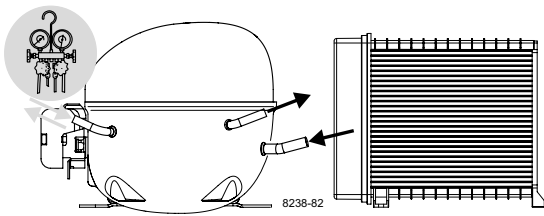

# Instructions

NLVE Compressors  
115-127 V, 50/60 Hz  
105N4100 Controllers

# SECCP

Keep electrical equipment  
clear from oil, chemicals,  
and water



## Service/Repair – R170, R290, R1270

(applies to all flammable refrigerants)

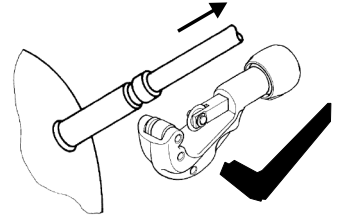
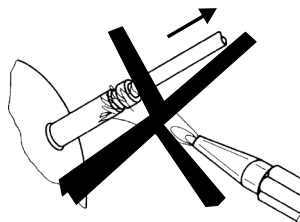

## Ensure Proper Airflow of 3 m/s at Both Compressor and Electronic Unit (Heatsink)

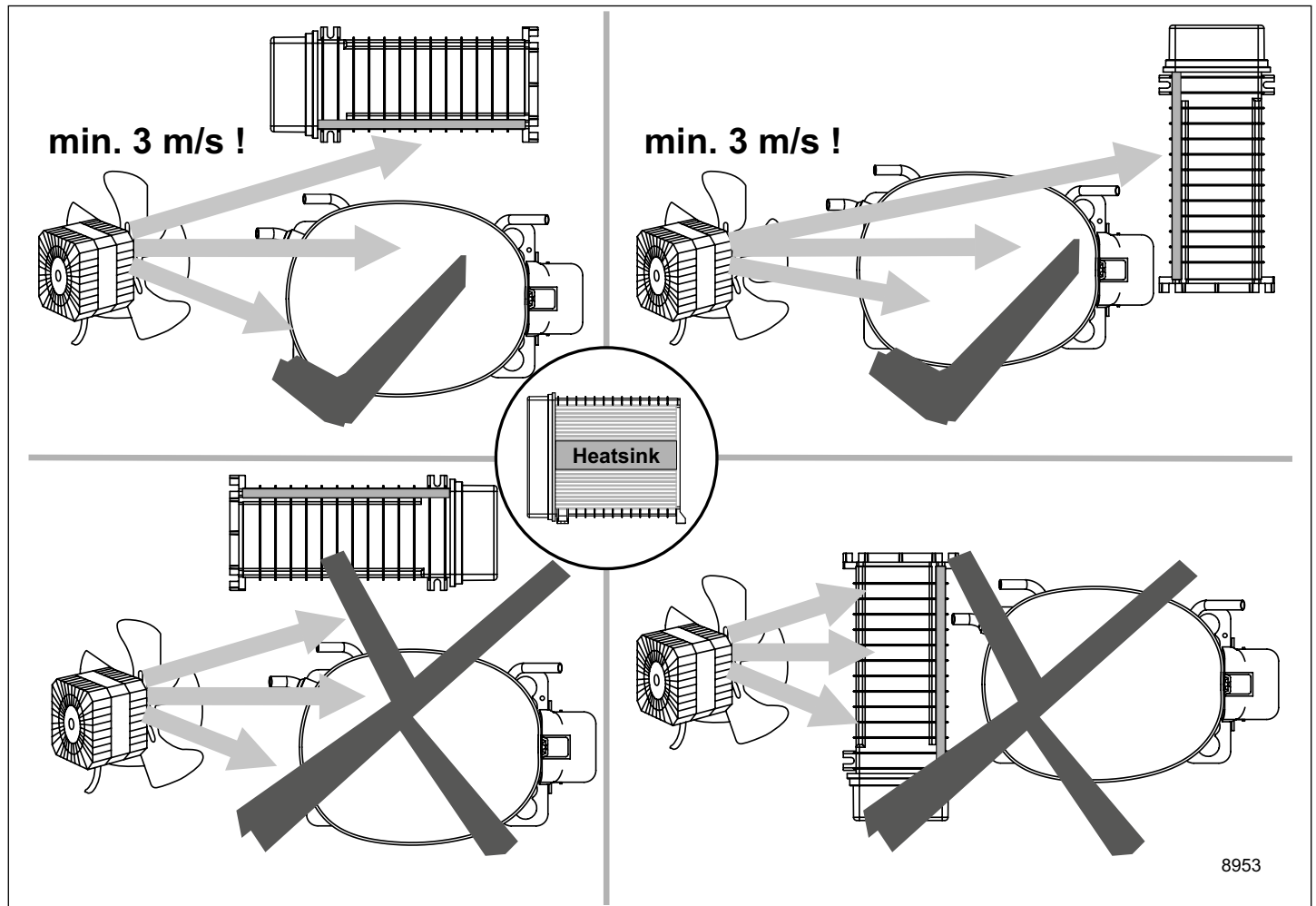

<b>Airflow</b>	3 m/s
<b>Operating conditions</b>	+ 5 °C to 43 °C - humidity < 90 % rH non condensing
<b>Storage conditions</b>	-25 °C to 70 °C - humidity < 90 % rH non condensing
<b>Supply voltage</b>	115-127 V (± 10 %)
<b>Frequency</b>	50/60 Hz
<b>Input power, max.</b>	1000 W

**Dismantling, recycling, disposal:** At the end of a compressor's lifecycle, proceed by separating and storing components according to their environmental impact. Parts that may cause pollution must be clearly identified and handled separately, ensuring appropriate disposal. Refrigerant gas must not be released into the environment and should be recovered by qualified operators. Compressor oil must also be collected separately. The compressor should be disposed of at specialized disposal centers in accordance with the applicable regulations. **Subject to modifications/alterations. [www.seccp.com](http://www.seccp.com)**