

Single Pack KLE4.0GFTX 220-240V 50Hz / 208-230V 60Hz LS CSIR

Single pack code number: **195B4817**

Position	Title	Code	Amount
1	Compressor KLE4.0GFTX	106G5408	1
2	Starting relay (QLZ-4.6A, overload protector T1189/L6)	117U7073	1
3	Starting capacitor (80µF 220V, 6.3mm)	117U5001	1
4	KL accessories	103N1060	1
5	Bolt joint for one compressor M6 ø16mm	118-1917	1

Secop GmbH • Lise-Meitner-Straße 29 • 24941 Flensburg, Germany • Tel: +49 461 4941 0 • www.secop.com

Secop accepts no responsibility for possible errors in catalogs, brochures, and other printed material. Secop reserves the right to alter its products without notice. This also applies to products already on order provided that such alterations can be made without subsequent changes being necessary to specifications already agreed. All trademarks in this material are the property of the respective companies. Secop and the Secop logotype are trademarks of Secop GmbH. All rights reserved.

Model

Designation	KLE4.0GFTX	220-240V/50Hz 1~ 208-230V/60Hz 1~	Sales code:	106G5408
-------------	-------------------	-----------------------------------	-------------	-----------------

Compressor design

Oil type	Polyolester	Refrigerant(s)	R134a, R513A
Oil viscosity	19,2cSt	Displacement	4cm ³ / 0,24cu.in
Oil quantity	240cm ³ / 8,1fl.oz	Compressors on pallet	100
Refr. charge - tech. limit	250g / 8,8oz		
Free gas volume comp.	1560cm ³ / 52,7fl.oz		
Weight	8,9kg / 19,6lbs		
Motor protection	external		
Winding resistance main	13,1Ω (at 25°C)		
Winding resistance aux	25,3Ω (at 25°C)		
Max. winding temp.	125°C / 257°F		
Max. discharge temp.	130°C / 266°F		
Additional note	Good robustness against liquid intake. Ice-cube maker optimization - indirect suction intake.		



General - Configurations with KLE4.0GFTX

	Conf. 1	Conf. 2
Motor configuration	CSIR	CSIR
Power supply (nominal)	220-240V/50Hz	208-230V/60Hz
Number of phases	1	1
Voltage range	187-254V	198-253V
Approvals	VDE, CB, UL	VDE, CB, UL
Starting torque	HST	HST
Note	Compressor with low height version.	

Applications with KLE4.0GFTX

	Conf. 1	Conf. 2
Refrigerant	R134a	R134a
Application	LBP+MBP+HBP	LBP+MBP
System cooling	static	static
Hot gas defrost	OK	OK
Long interval pull down	OK	OK

Electrical data - Configurations with KLE4.0GFTX

	Conf. 1	Conf. 2
Starting device type	relay	relay
Run capacitor	-/-	-/-
Start capacitor	80μF	80μF
LRA (locked rotor amps / 4s/ U(N))	10,5A	
RLA (rated load amps / 1s/ U(N))	1A	
Cut in current (U(N))	10,2A	

Model

Designation **KLE4.0GFTX** 220-240V/50Hz 1~ 208-230V/60Hz 1~ Sales code: **106G5408**

Compressor dimensions

Housing	A Height	174mm / 6,85in
	B Height	167mm / 6,57in
	C Length shell	194mm / 7,64in
	D Length w. cover	235,1mm / 9,26in
	E Width	151mm / 5,94in

Connectors		Suction	Discharge	Process
		X	Y	Z
Diameter	[mm]	øi 8,11-8,29	øi 6,11-6,29	øi 6,11-6,29
(i:inside, o:outside)	[in]	øi 0,32-0,33	øi 0,24-0,25	øi 0,24-0,25
Material		copper	copper	copper
Horizontal angle	±2°	35°	13°	0°
Vertical angle	±2°	30°	40°	145°
Position l/h/w	[mm]	119/73/59	114/107/63	-87/101/71
	[in]	4,7/2,9/2,3	4,5/4,2/2,5	-3,4/4/2,8
Straight tube l.	[mm]	14	14	14
	[in]	0,5	0,5	0,5

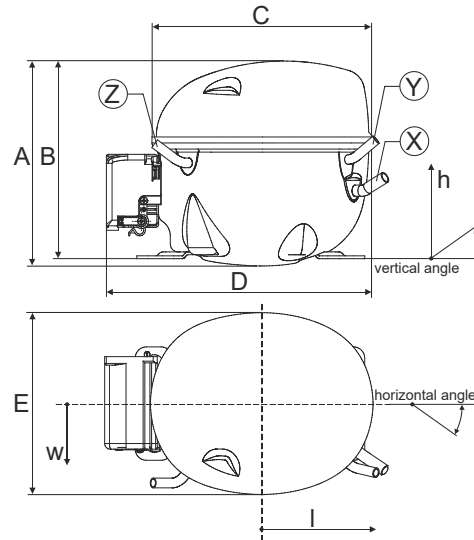

Compressor fixation

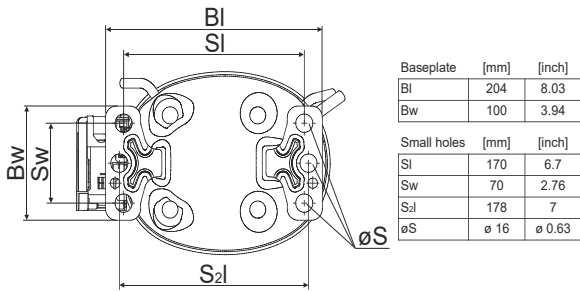

Bolt joint

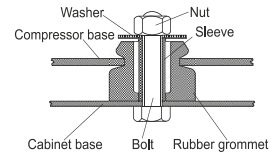

Snap-on

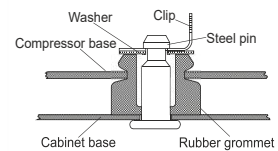

Mounting accessories	one comp.	multi pack
Bolt joint M6 ø16mm	118-1917	118-1918
Bolt joint ø1/4" ø16mm	118-1946	
Snap-on ø7,3 ø16mm	118-1947	118-1919

Application notes

Provision for PE Grounding is located at the PE Stamp on the compressor

Model

Designation **KLE4.0GFTX** **220-240V/50Hz** Conf. 1 Sales code: **106G5408**

Configuration

Motor configuration CSIR
 Power supply (nominal) 220-240V/50Hz 1~
 Refrigerant R134a
 Application LBP+MBP+HBP
 Voltage range 187-254V
 Starting torque HST
 Approvals VDE
 CB
 UL

Electrical accessories / wiring diagram

CSIR

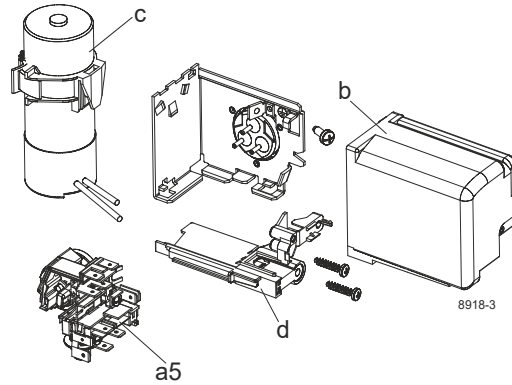

Ambient/ machine room temperatures minimum /maximum

Ambient temperature range: 10 - 43°C / 50 - 110°F
 Machine room temperature range: 10 - 48°C / 50 - 119°F

Compressor cooling: static

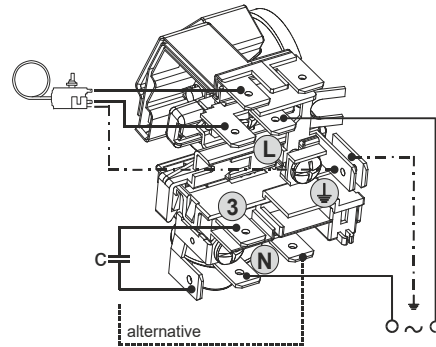

Operation pressure range

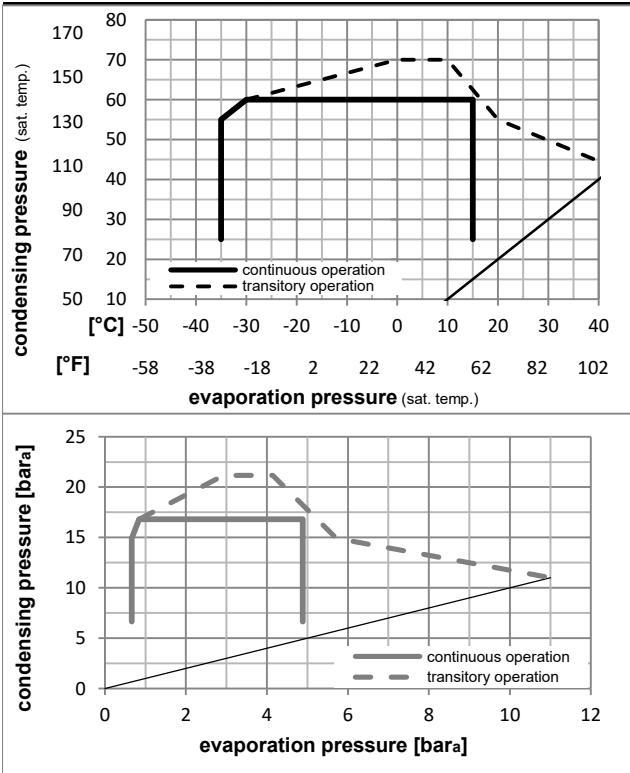

Components

- | | | |
|------|------------------------------------|----------|
| a5 | current relay (T1189/L6-S3) | 117U7073 |
| c | start capacitor (80µF, 6.3mm) | 117U5001 |
| b, d | cover + clamp + screws(5VA-compl.) | 103N0600 |

Alternative components

- | | | |
|------|------------------------------------|----------|
| b, d | 100x cover + clamp + screws(5VA) | 103N2060 |
| b, d | cover + clamp + screws(5VA) in bag | 103N1060 |

Model

Designation **KLE4.0GFTX 220-240V/50Hz** Conf. 1 Sales code: **106G5408**

Optimization + standard conditions

R134a, 220V/50Hz, CSIR, static, VDE, CB, UL

	Evaporating pressure (saturation temperature)				Condensing pressure (saturation temperature)			Return gas temp.			Liquid temp.			Cooling capacity			COP	EER	Power consumption			
	pe	pc	RGT	Tliq	[W]	[Btu/h]	[kcal/h]	[W/W]	[Btu/Wh]	[kcal/Wh]	P1	I	m	[W]	[A]	[kg/h]						
[°C]	-23	54	32	32	101,4	346	87,3	1,14	3,90	0,98	88,8	1,15	1,97									
[°F]	-10	130	90	90																	ASHRAE LBP	
[°C]	-7	54	35	46	221,7	757	190,8	1,77	6,03	1,52	125,5	1,23	4,84								ASHRAE MBP	
[°F]	20	130	95	115																		
[°C]	7,2	54	35	46	398,3	1360	342,8	2,58	8,81	2,22	154,4	1,31	8,84								ASHRAE HBP	
[°F]	45	130	95	115																		
[°C]	-35	40	20	40	46,0	157	39,6	0,72	2,47	0,62	63,5	1,10	1,01								EN12900 LBP	
[°F]	-31	104	68	104																		
[°C]	-10	45	20	45	191,3	653	164,6	1,74	5,93	1,49	110,1	1,20	4,48								EN12900 MBP	
[°F]	14	113	68	113																		
[°C]	5	50	20	50	339,4	1159	292,1	2,36	8,07	2,03	143,6	1,28	8,55								EN12900 HBP	
[°F]	41	122	68	122																		

Performance tables

R134a, 220V/50Hz, CSIR, static, VDE, CB, UL

	pe		Cooling capacity			COP	EER	P1	I	m	
	[°C]	[°F]	[W]	[Btu/h]	[kcal/h]	[W/W]	[Btu/Wh]	[kcal/Wh]	[W]	[A]	[kg/h]
[°C / °F]	-35	-31	43,4	148	37,4	0,69	2,34	0,59	63,3	1,10	0,94
cond. pressure	-25	-13	86,8	296	74,7	1,05	3,57	0,90	82,9	1,14	1,88
pc= 45/113	-15	5	154,2	527	132,7	1,52	5,20	1,31	101,2	1,18	3,36
return gas temp.	-10	14	198,5	678	170,8	1,80	6,15	1,55	110,1	1,20	4,34
RGT= 32/90	0	32	310,9	1062	267,6	2,43	8,31	2,09	127,7	1,24	6,88
liquid temp	5	41	380,4	1299	327,4	2,78	9,51	2,40	136,6	1,26	8,47
Tliq= 45/113	15	59	548,6	1874	472,1	3,54	12,09	3,05	154,9	1,31	12,43
[°C / °F]	-35	-31	35,4	121	30,5	0,59	2,01	0,51	60,0	1,10	0,84
cond. pressure	-25	-13	73,8	252	63,5	0,87	2,97	0,75	84,9	1,15	1,76
pc= 55/131	-15	5	132,4	452	114,0	1,23	4,19	1,06	107,8	1,19	3,19
return gas temp	-10	14	170,8	583	147,0	1,44	4,91	1,24	118,8	1,22	4,13
RGT= 32/90	0	32	268,7	918	231,3	1,92	6,55	1,65	140,0	1,27	6,57
liquid temp	5	41	329,4	1125	283,5	2,19	7,48	1,88	150,5	1,30	8,12
Tliq= 55/131	15	59	477,3	1630	410,8	2,78	9,50	2,40	171,5	1,36	11,99

Model

Designation **KLE4.0GFTX** **208-230V/60Hz** Conf. 2 Sales code: **106G5408**

Configuration

Motor configuration CSIR
 Power supply (nominal) 208-230V/60Hz 1~
 Refrigerant R134a
 Application LBP+MBP
 Voltage range 198-253V
 Starting torque HST
 Approvals VDE
 CB
 UL

Electrical accessories / wiring diagram

CSIR

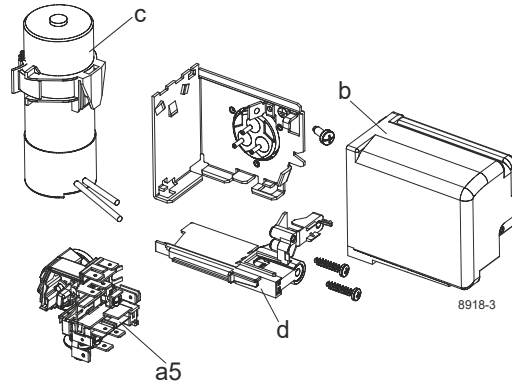

Ambient/ machine room temperatures minimum /maximum

Ambient temperature range: 10 - 43°C / 50 - 110°F

Machine room temperature range: 10 - 48°C / 50 - 119°F

Compressor cooling: static

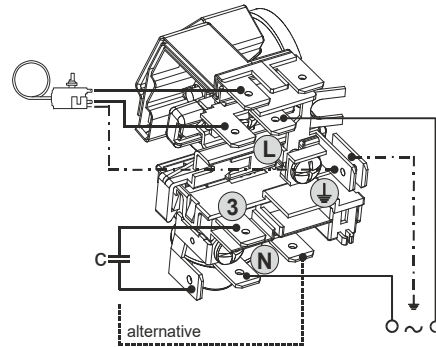

Operation pressure range

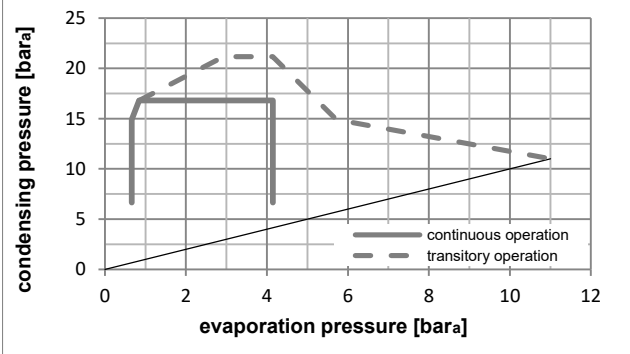
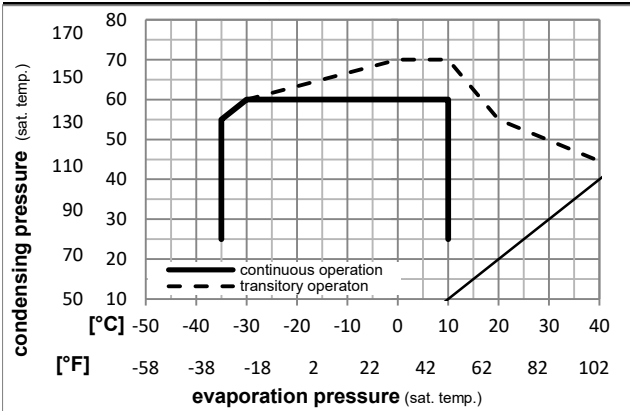

Components

a5	current relay (T1189/L6-S3)	117U7073
c	start capacitor (80µF, 6.3mm)	117U5001
b, d	cover + clamp + screws(5VA-compl.)	103N0600

Alternative components

b, d	100x cover + clamp + screws(5VA)	103N2060
b, d	cover + clamp + screws(5VA) in bag	103N1060

Model

Designation **KLE4.0GFTX** **208-230V/60Hz** Conf. 2 Sales code: **106G5408**

Optimization + standard conditions

R134a, 230V/60Hz, CSIR, static, VDE, CB, UL

	Evaporating pressure (saturation temperature)				Condensing pressure (saturation temperature)			COP	EER	Power consumption			ASHRAE	
	pe	pc	RGT	Tliq	[W]	[Btu/h]	[kcal/h]			P1	I	m		
	[°C]	[°F]	[°C]	[°F]	[W]	[Btu/h]	[kcal/h]	[W/W]	[Btu/Wh]	[kcal/Wh]	[W]	[A]	[kg/h]	
	-23	54	32	32	122,9	420	105,8	1,20	4,10	1,03	102,4	1,10	2,39	ASHRAE LBP
	-10	130	90	90										
	-7	54	35	46	261,5	893	225,1	1,81	6,20	1,56	144,1	1,19	5,71	ASHRAE MBP
	20	130	95	115										
	7,2	54	35	46	465,1	1589	400,3	2,58	8,82	2,22	180,1	1,28	10,32	ASHRAE HBP
	45	130	95	115										
	-35	40	20	40	55,1	188	47,4	0,76	2,59	0,65	72,7	1,06	1,21	EN12900 LBP
	-31	104	68	104										
	-10	45	20	45	224,4	767	193,2	1,76	6,00	1,51	127,8	1,15	5,25	EN12900 MBP
	14	113	68	113										
	5	50	20	50	395,7	1351	340,6	2,34	7,98	2,01	169,3	1,25	9,97	EN12900 HBP
	41	122	68	122										

Performance tables

R134a, 230V/60Hz, CSIR, static, VDE, CB, UL

	pe		Cooling capacity			COP	EER		P1	I	m
	[°C]	[°F]	[W]	[Btu/h]	[kcal/h]	[W/W]	[Btu/Wh]	[kcal/Wh]	[W]	[A]	[kg/h]
[°C / °F]	-35	-31	50,9	174	43,8	0,71	2,42	0,61	71,8	1,06	1,10
cond. pressure	-25	-13	104,5	357	90,0	1,10	3,77	0,95	94,7	1,09	2,26
pc= 45/113	-15	5	182,4	623	157,0	1,56	5,33	1,34	116,8	1,13	3,98
return gas temp.	-10	14	232,9	795	200,4	1,82	6,22	1,57	127,8	1,15	5,10
RGT= 32/90	0	32	361,9	1236	311,5	2,40	8,21	2,07	150,6	1,20	8,00
liquid temp	5	41	442,5	1511	380,8	2,72	9,29	2,34	162,6	1,23	9,85
Tliq= 45/113	15	59	640,8	2188	551,5	3,40	11,60	2,92	188,7	1,30	14,51
[°C / °F]	-35	-31	38,9	133	33,5	0,54	1,85	0,47	71,7	1,06	0,93
cond. pressure	-25	-13	89,4	305	77,0	0,91	3,10	0,78	98,4	1,10	2,14
pc= 55/131	-15	5	158,6	542	136,5	1,28	4,38	1,10	123,7	1,14	3,82
return gas temp	-10	14	202,7	692	174,5	1,49	5,08	1,28	136,2	1,17	4,90
RGT= 32/90	0	32	314,9	1075	271,0	1,95	6,66	1,68	161,6	1,23	7,70
liquid temp	5	41	385,0	1315	331,3	2,20	7,53	1,90	174,7	1,26	9,49
Tliq= 55/131	15	59	558,0	1906	480,3	2,76	9,41	2,37	202,5	1,34	14,02

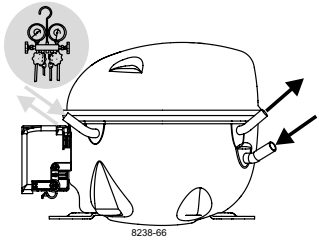

8238-66

KL Compressors



Keep electrical equipment clear from oil, chemicals, and water



When operated with a flammable refrigerant, only spark-proof starting equipment is allowed.

RSIR

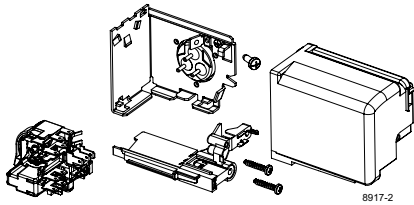

8917-2

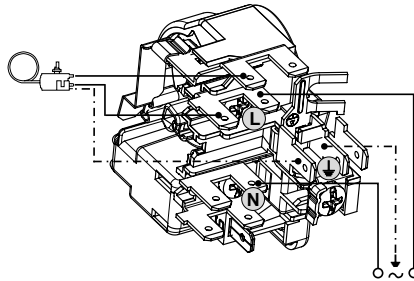

RSCR

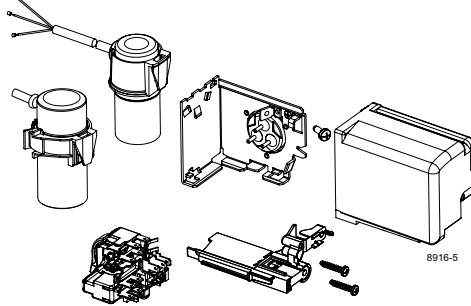

8916-5

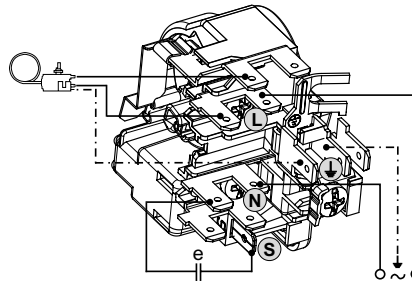

CSIR

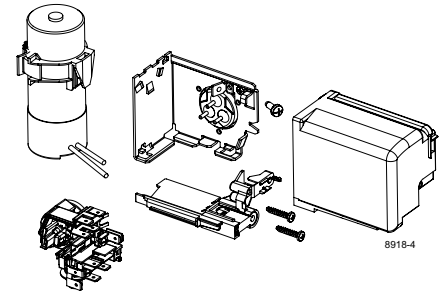

8918-4

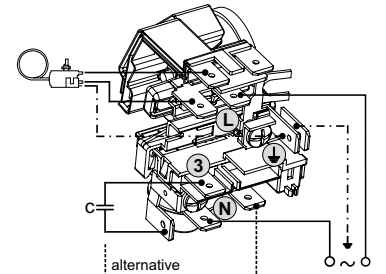

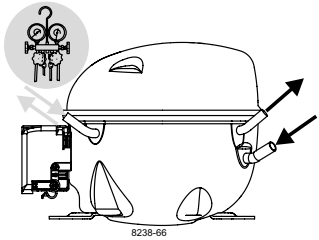

KL Compressors



Keep electrical equipment clear from oil, chemicals, and water



 When operated with a flammable refrigerant, only spark-proof starting equipment is allowed.

Service/Repair – R290, R600a, R170, R1270, R1234yf (applies to all flammable refrigerants)

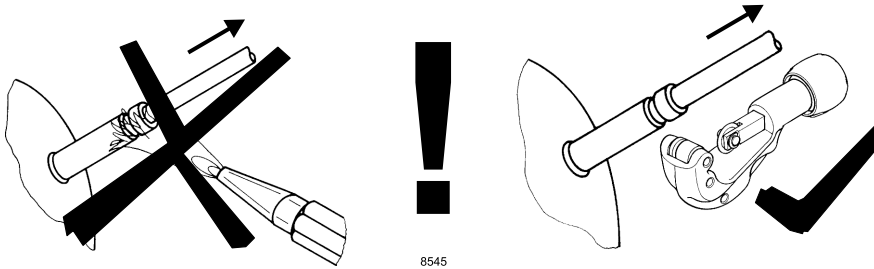

Dismantling, recycling, disposal: At the end of a compressor's lifecycle, proceed by separating and storing components according to their environmental impact. Parts that may cause pollution must be clearly identified and handled separately, ensuring appropriate disposal. Refrigerant gas must not be released into the environment and should be recovered by qualified operators. Compressor oil must also be collected separately. The compressor should be disposed of at specialized disposal centers in accordance with the applicable regulations. **Subject to modifications/alterations. www.seccp.com**