

Single Pack KLE4.8GFTX 220-240V 50Hz / 208-230V 60Hz LS CSIR

Single pack code number: **195B4818**

Position	Title	Code	Amount
1	Compressor KLE4.8GFTX	106G5508	1
2	Starting relay (QLZ-4.6A, overload protector T1189/L6)	117U7073	1
3	Starting capacitor (80 μ F 220V, 6.3mm)	117U5001	1
4	KL accessories	103N1060	1
5	Bolt joint for one compressor M6 \varnothing 16mm	118-1917	1

Secop GmbH • Lise-Meitner-Straße 29 • 24941 Flensburg, Germany • Tel: +49 461 4941 0 • www.secop.com

Secop accepts no responsibility for possible errors in catalogs, brochures, and other printed material. Secop reserves the right to alter its products without notice. This also applies to products already on order provided that such alterations can be made without subsequent changes being necessary to specifications already agreed. All trademarks in this material are the property of the respective companies. Secop and the Secop logotype are trademarks of Secop GmbH. All rights reserved.

Model

Designation	KLE4.8GFTX	220-240V/50Hz 1~ 208-230V/60Hz 1~	Sales code:	106G5508
-------------	-------------------	--	-------------	-----------------

Compressor design

Oil type	Polyolester	Refrigerant(s)	R134a, R513A
Oil viscosity	19,2cSt	Displacement	4,8cm ³ / 0,29cu.in
Oil quantity	240cm ³ / 8,1fl.oz	Compressors on pallet	100
Refr. charge - tech. limit	250g / 8,8oz		
Free gas volume comp.	1545cm ³ / 52,2fl.oz		
Weight	9,3kg / 20,5lbs		
Motor protection	external		
Winding resistance main	13,1Ω (at 25°C)		
Winding resistance aux	25,3Ω (at 25°C)		
Max. winding temp.	125°C / 257°F		
Max. discharge temp.	130°C / 266°F		
Additional note	Good robustness against liquid intake. Ice-cube maker optimization - indirect suction intake.		



General - Configurations with KLE4.8GFTX

	Conf. 1	Conf. 2
Motor configuration	CSIR	CSIR
Power supply (nominal)	220-240V/50Hz	208-230V/60Hz
Number of phases	1	1
Voltage range	187-254V	198-253V
Approvals	VDE, CB, CCC, UL	VDE, CB, CCC, UL
Starting torque	HST	HST
Note	Compressor with low height version.	

Applications with KLE4.8GFTX

	Conf. 1	Conf. 2
Refrigerant	R134a	R134a
Application	LBP+MBP+HBP	LBP+MBP
System cooling	fan 3m/s	fan 3m/s
Hot gas defrost	OK	OK
Long interval pull down	OK	OK

Electrical data - Configurations with KLE4.8GFTX

	Conf. 1	Conf. 2
Starting device type	relay	relay
Run capacitor	-/-	-/-
Start capacitor	80μF	80μF
LRA (locked rotor amps / 4s/ U(N))	10,5A	
RLA (rated load amps / 1s/ U(N))	1A	
Cut in current (U(N))	10,2A	

Model

Designation **KLE4.8GFTX** 220-240V/50Hz 1~ 208-230V/60Hz 1~ Sales code: **106G5508**

Compressor dimensions

Housing	A Height	174mm / 6,85in
	B Height	167mm / 6,57in
	C Length shell	194mm / 7,64in
	D Length w. cover	235,1mm / 9,26in
	E Width	151mm / 5,94in

Connectors		Suction	Discharge	Process
		X	Y	Z
Diameter	[mm]	øi 8,11-8,29	øi 6,11-6,29	øi 6,11-6,29
	(i:inside, o:outside) [in]	øi 0,32-0,33	øi 0,24-0,25	øi 0,24-0,25
Material		copper	copper	copper
Horizontal angle	±2°	35°	13°	0°
Vertical angle	±2°	30°	40°	145°
Position l/h/w	[mm]	119/73/59	114/107/63	-87/101/71
	[in]	4,7/2,9/2,3	4,5/4,2/2,5	-3,4/4/2,8
Straight tube l.	[mm]	14	14	14
	[in]	0,5	0,5	0,5

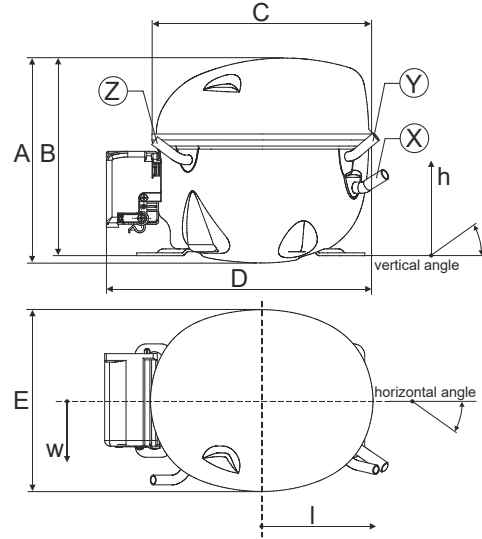

Compressor fixation

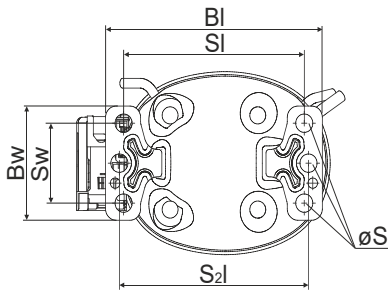

Baseplate	[mm]	[inch]
BI	204	8.03
Bw	100	3.94
Small holes		
SI	170	6.7
Sw	70	2.76
S2l	178	7
øS	ø 16	ø 0.63

Bolt joint

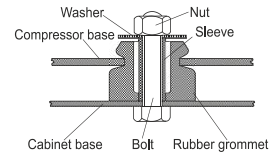

Snap-on

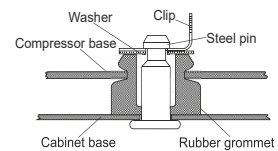

Mounting accessories	one comp.	multi pack
Bolt joint M6 ø16mm	118-1917	118-1918
Bolt joint ø1/4" ø16mm	118-1946	
Snap-on ø7,3 ø16mm	118-1947	118-1919

Application notes

Provision for PE Grounding is located at the PE Stamp on the compressor

Model

Designation **KLE4.8GFTX** **220-240V/50Hz** Conf. 1 Sales code: **106G5508**

Configuration

Motor configuration CSIR
 Power supply (nominal) 220-240V/50Hz 1~
 Refrigerant R134a
 Application LBP+MBP+HBP
 Voltage range 187-254V
 Starting torque HST
 Approvals VDE
 CB
 CCC
 UL

Electrical accessories / wiring diagram

CSIR

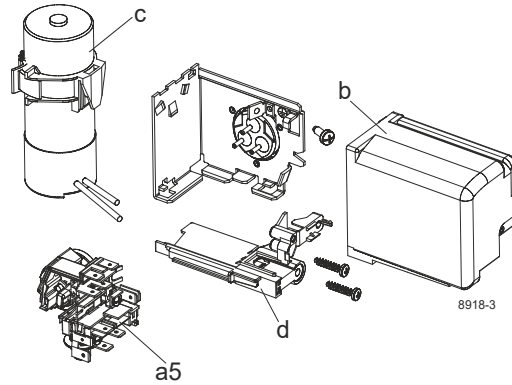

Ambient/ machine room temperatures minimum /maximum

Ambient temperature range: 10 - 43°C / 50 - 110°F

Machine room temperature range: 10 - 48°C / 50 - 119°F

Compressor cooling: fan 3m/s

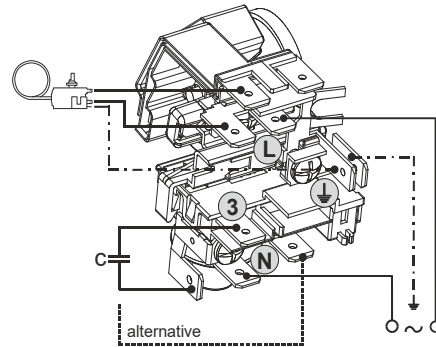

Operation pressure range

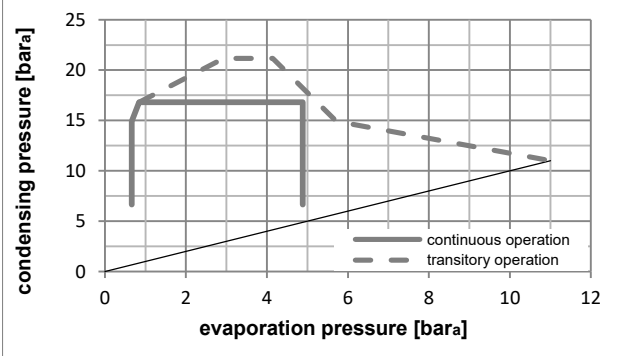
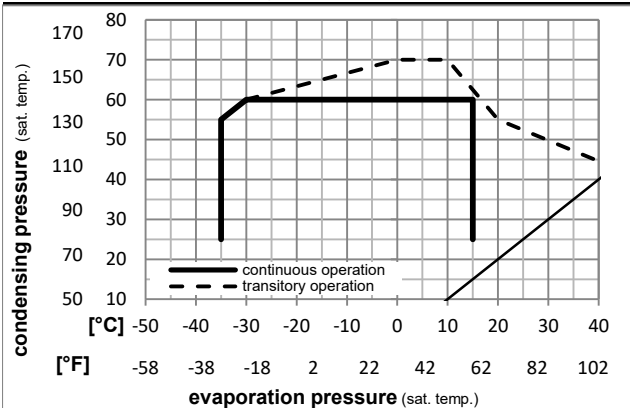

Components

- a5 current relay (T1189/L6-S3) 117U7073
- c start capacitor (80µF, 6.3mm) 117U5001
- b, d cover + clamp + screws(5VA-compl.) 103N0600

Alternative components

- b, d 100x cover + clamp + screws(5VA) 103N2060
- b, d cover + clamp + screws(5VA) in bag 103N1060

Model

Designation **KLE4.8GFTX 220-240V/50Hz** Conf. 1 Sales code: **106G5508**

Optimization + standard conditions

R134a, 220V/50Hz, CSIR, fan 3m/s, VDE, CB, CCC, UL

	Evaporating pressure (saturation temperature)				Cooling capacity			COP	EER		Power consumption			
	Condensing pressure (saturation temperature)				Return gas temp.						Current consumption			Ref. mass flow
	pe	pc	RGT	Tliq	[W]	[Btu/h]	[kcal/h]	[W/W]	[Btu/Wh]	[kcal/Wh]	P1	I	m	
	[°C]	[°C]	[°C]	[°C]	[W]	[Btu/h]	[kcal/h]	[W/W]	[Btu/Wh]	[kcal/Wh]	[W]	[A]	[kg/h]	
ASHRAE LBP	-23	54	32	32	129,7	443	111,6	1,26	4,31	1,09	102,8	1,18	2,52	
	[-10]	130	90	90										
ASHRAE MBP	-7	54	35	46	279,9	956	240,9	1,88	6,42	1,62	148,9	1,29	6,11	
	[20]	130	95	115										
ASHRAE HBP	7,2	54	35	46	502,3	1715	432,3	2,71	9,26	2,33	185,2	1,41	11,14	
	[45]	130	95	115										
EN12900 LBP	-35	40	20	40	64,4	220	55,4	0,88	3,01	0,76	73,0	1,12	1,41	
	[-31]	104	68	104										
EN12900 MBP	-10	45	20	45	241,7	825	208,0	1,87	6,38	1,61	129,3	1,24	5,66	
	[14]	113	68	113										
EN12900 HBP	5	50	20	50	428,2	1462	368,5	2,49	8,51	2,15	171,8	1,36	10,79	
	[41]	122	68	122										

Performance tables

R134a, 220V/50Hz, CSIR, fan 3m/s, VDE, CB, CCC, UL

	pe		Cooling capacity			COP	EER		P1	I	m
	[°C]	[°F]	[W]	[Btu/h]	[kcal/h]	[W/W]	[Btu/Wh]	[kcal/Wh]	[W]	[A]	[kg/h]
[°C / °F]	-35	-31	60,4	206	52,0	0,83	2,85	0,72	72,4	1,12	1,30
cond. pressure	-25	-13	111,8	382	96,2	1,17	4,00	1,01	95,5	1,17	2,42
pc= 45/113	-15	5	195,3	667	168,1	1,65	5,65	1,42	118,1	1,22	4,26
return gas temp.	-10	14	250,7	856	215,8	1,94	6,62	1,67	129,3	1,24	5,49
RGT= 32/90	0	32	392,4	1340	337,7	2,59	8,83	2,23	151,7	1,30	8,68
liquid temp	5	41	479,9	1639	413,0	2,95	10,06	2,53	163,0	1,33	10,69
Tliq= 45/113	15	59	691,7	2362	595,3	3,72	12,72	3,20	185,8	1,41	15,67
[°C / °F]	-35	-31	48,8	167	42,0	0,72	2,46	0,62	67,8	1,11	1,16
cond. pressure	-25	-13	94,7	324	81,5	0,97	3,30	0,83	97,9	1,17	2,27
pc= 55/131	-15	5	167,6	572	144,3	1,32	4,52	1,14	126,6	1,24	4,04
return gas temp	-10	14	215,8	737	185,7	1,54	5,25	1,32	140,4	1,27	5,22
RGT= 32/90	0	32	339,1	1158	291,8	2,03	6,92	1,74	167,3	1,35	8,29
liquid temp	5	41	415,5	1419	357,6	2,30	7,87	1,98	180,4	1,39	10,24
Tliq= 55/131	15	59	601,1	2053	517,3	2,92	9,96	2,51	206,1	1,49	15,10

Model

Designation **KLE4.8GFTX** **208-230V/60Hz** Conf. 2 Sales code: **106G5508**

Configuration

Motor configuration CSIR
 Power supply (nominal) 208-230V/60Hz 1~
 Refrigerant R134a
 Application LBP+MBP
 Voltage range 198-253V
 Starting torque HST
 Approvals VDE
 CB
 CCC
 UL

Electrical accessories / wiring diagram

CSIR

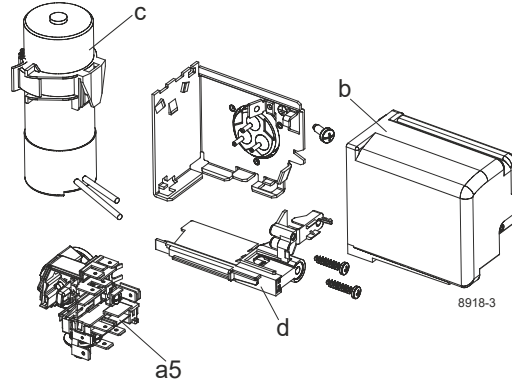

Ambient/ machine room temperatures minimum /maximum

Ambient temperature range: 10 - 43°C / 50 - 110°F

Machine room temperature range: 10 - 48°C / 50 - 119°F

Compressor cooling: fan 3m/s

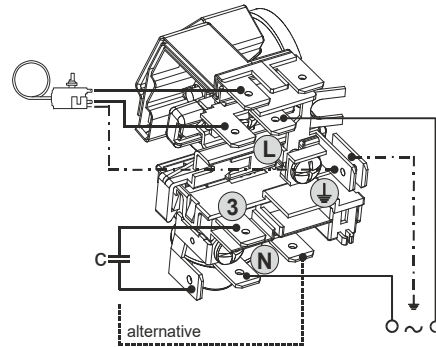

Operation pressure range

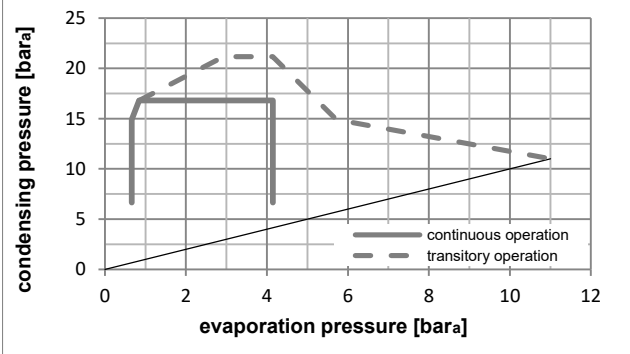
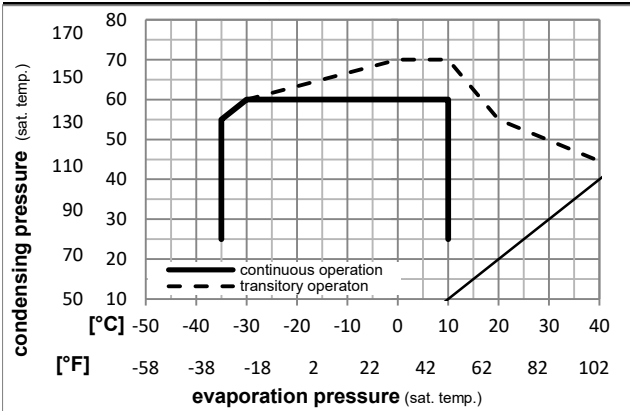

Components

- | | | |
|------|------------------------------------|----------|
| a5 | current relay (T1189/L6-S3) | 117U7073 |
| c | start capacitor (80µF, 6.3mm) | 117U5001 |
| b, d | cover + clamp + screws(5VA-compl.) | 103N0600 |

Alternative components

- | | | |
|------|------------------------------------|----------|
| b, d | 100x cover + clamp + screws(5VA) | 103N2060 |
| b, d | cover + clamp + screws(5VA) in bag | 103N1060 |

Model

Designation **KLE4.8GFTX** **208-230V/60Hz** Conf. 2 Sales code: **106G5508**

Optimization + standard conditions

R134a, 230V/60Hz, CSIR, fan 3m/s, VDE, CB, CCC, UL

	Evaporating pressure (saturation temperature)				Condensing pressure (saturation temperature)			COP	EER			Power consumption			ASHRAE
	pe	pc	RGT	Tliq	[W]	[Btu/h]	[kcal/h]		[W/W]	[Btu/Wh]	[kcal/Wh]	P1	I	m	
	[°C]	[°C]	[°C]	[°C]	[W]	[Btu/h]	[kcal/h]	[W/W]	[Btu/Wh]	[kcal/Wh]	[W]	[A]	[kg/h]		
	-23	54	32	32	154,4	527	132,9	1,30	4,44	1,12	118,6	1,13	3,00	ASHRAE LBP	
	[°F]														
	-10	130	90	90											
	[°C]	-7	54	35	46	330,5	1129	284,4	1,92	6,55	1,65	172,2	1,26	7,21	ASHRAE MBP
	[°F]	20	130	95	115										
	[°C]	7,2	54	35	46	587,3	2006	505,4	2,71	9,25	2,33	216,9	1,39	13,03	ASHRAE HBP
	[°F]	45	130	95	115										
	[°C]	-35	40	20	40	81,6	279	70,2	0,94	3,22	0,81	86,7	1,08	1,79	EN12900 LBP
	[°F]	-31	104	68	104										
	[°C]	-10	45	20	45	281,8	963	242,6	1,87	6,39	1,61	150,6	1,20	6,60	EN12900 MBP
	[°F]	14	113	68	113										
	[°C]	5	50	20	50	500,8	1710	431,0	2,45	8,37	2,11	204,3	1,35	12,62	EN12900 HBP
	[°F]	41	122	68	122										

Performance tables

R134a, 230V/60Hz, CSIR, fan 3m/s, VDE, CB, CCC, UL

	pe		Cooling capacity			COP	EER		P1	I	m
	[°C]	[°F]	[W]	[Btu/h]	[kcal/h]	[W/W]	[Btu/Wh]	[kcal/Wh]	[W]	[A]	[kg/h]
[°C / °F]	-35	-31	76,1	260	65,5	0,89	3,05	0,77	85,3	1,07	1,64
cond. pressure	-25	-13	131,2	448	112,9	1,21	4,13	1,04	108,4	1,11	2,84
pc= 45/113	-15	5	227,5	777	195,8	1,68	5,72	1,44	135,8	1,17	4,96
return gas temp.	-10	14	292,4	999	251,6	1,94	6,63	1,67	150,6	1,20	6,40
RGT= 32/90	0	32	458,1	1565	394,3	2,53	8,64	2,18	181,0	1,28	10,13
liquid temp	5	41	560,0	1912	481,9	2,85	9,75	2,46	196,2	1,33	12,47
Tliq= 45/113	15	59	804,3	2747	692,2	3,57	12,20	3,07	225,2	1,42	18,22
[°C / °F]	-35	-31	61,0	208	52,5	0,71	2,43	0,61	85,9	1,08	1,45
cond. pressure	-25	-13	113,1	386	97,4	0,99	3,39	0,85	114,1	1,12	2,71
pc= 55/131	-15	5	198,8	679	171,1	1,37	4,66	1,18	145,5	1,19	4,78
return gas temp	-10	14	255,4	872	219,8	1,58	5,39	1,36	161,9	1,23	6,18
RGT= 32/90	0	32	398,9	1362	343,3	2,05	7,00	1,76	194,7	1,32	9,76
liquid temp	5	41	486,8	1662	418,9	2,31	7,89	1,99	210,7	1,37	12,00
Tliq= 55/131	15	59	697,4	2382	600,2	2,90	9,90	2,50	240,5	1,48	17,52

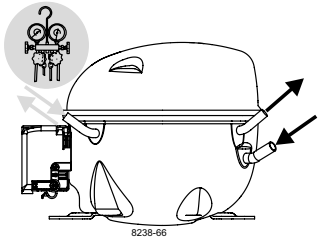

8238-66

KL Compressors

SECCP

Keep electrical equipment clear from oil, chemicals, and water



When operated with a flammable refrigerant, only spark-proof starting equipment is allowed.

RSIR

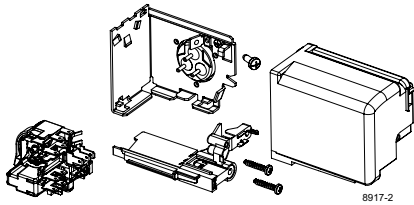

8917-2

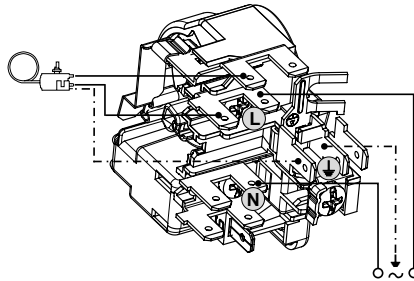

RSCR

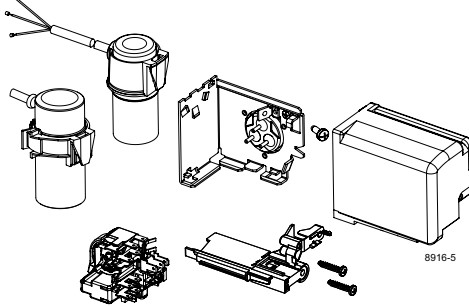

8916-5

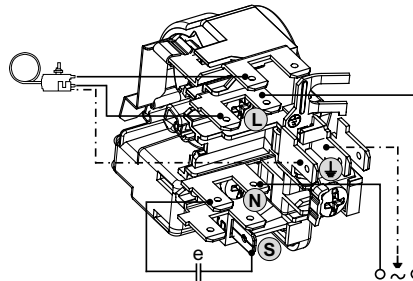

CSIR

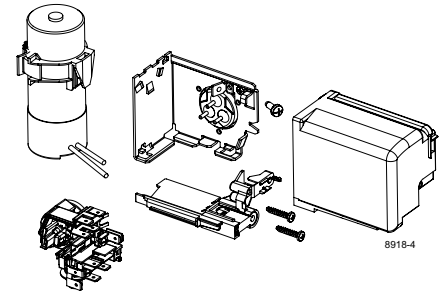

8918-4

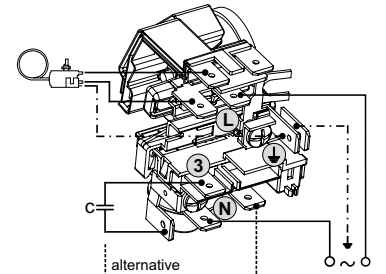

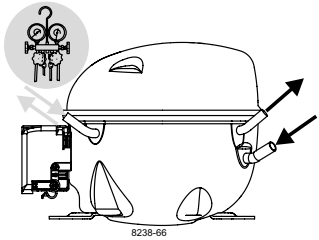

KL Compressors



Keep electrical equipment clear from oil, chemicals, and water



 When operated with a flammable refrigerant, only spark-proof starting equipment is allowed.

Service/Repair – R290, R600a, R170, R1270, R1234yf (applies to all flammable refrigerants)

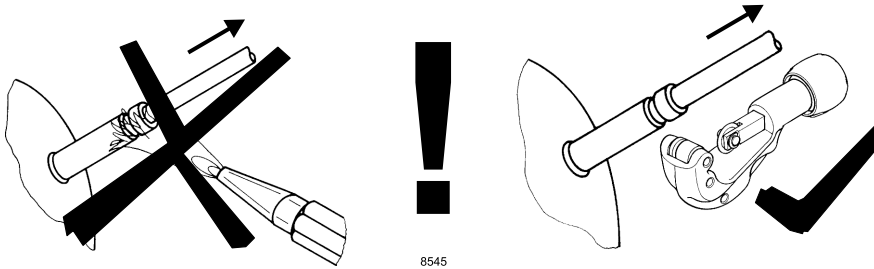

Dismantling, recycling, disposal: At the end of a compressor's lifecycle, proceed by separating and storing components according to their environmental impact. Parts that may cause pollution must be clearly identified and handled separately, ensuring appropriate disposal. Refrigerant gas must not be released into the environment and should be recovered by qualified operators. Compressor oil must also be collected separately. The compressor should be disposed of at specialized disposal centers in accordance with the applicable regulations. **Subject to modifications/alterations. www.seccp.com**